

SS74126

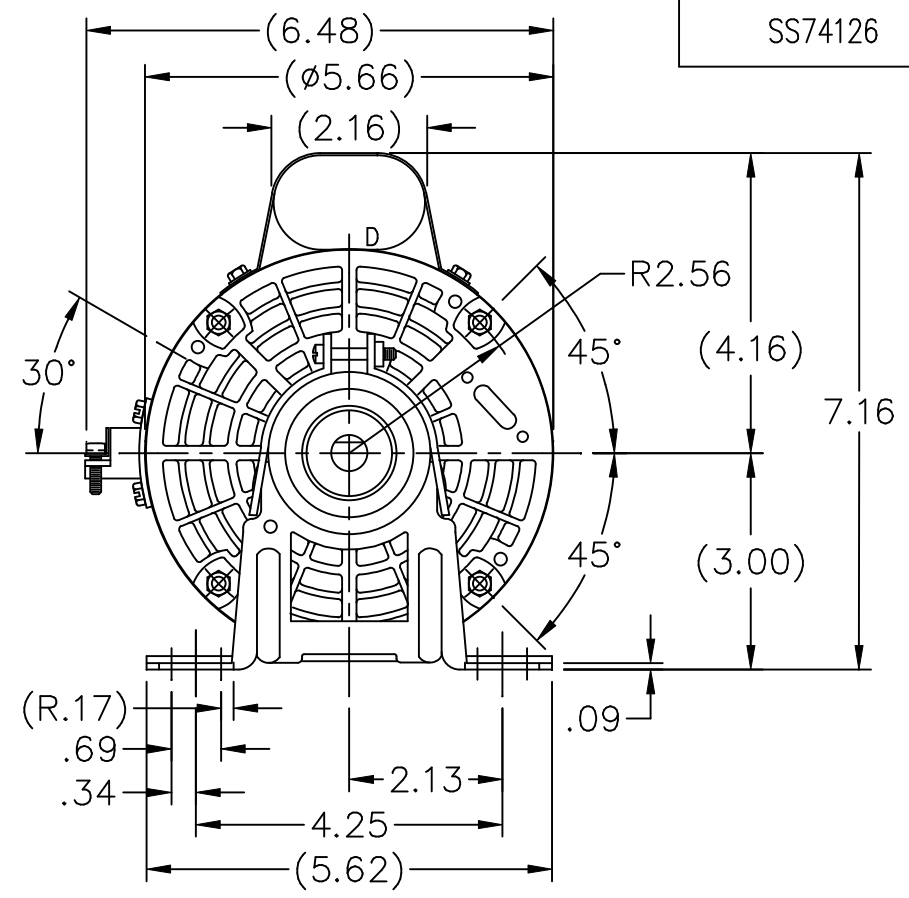

LEAD DESCRIPTION:
 1 BLACK AND 1 WHITE LEAD WITH .50 BARE WIRE STRIP EXIT MOTOR THROUGH CONDUIT CONNECTOR WITH ADJUSTABLE THROAT OPENING. 35.00-37.00" LONG PURPLE AND YELLOW REVERSING LEADS MOLDED INTO MATING PULL-APART PLUGS. 4.00-6.00 LONG.

DASH	C	XB
425	8.50	3.67
475	9.00	4.17

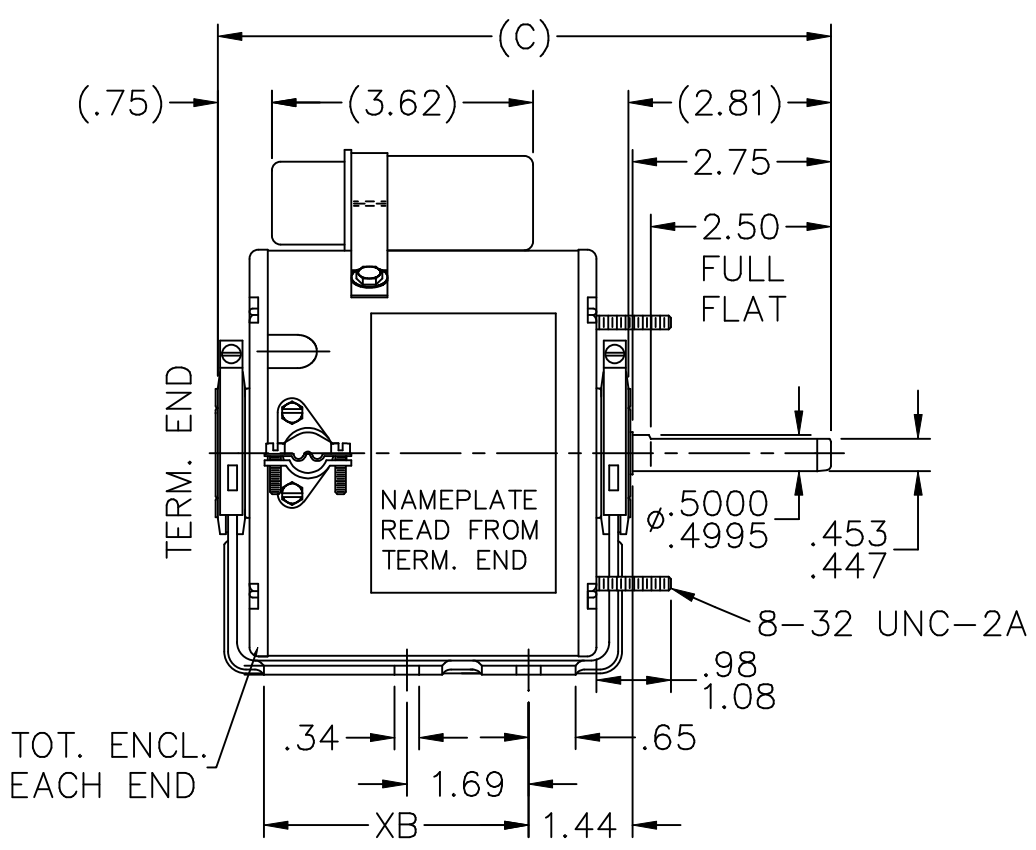
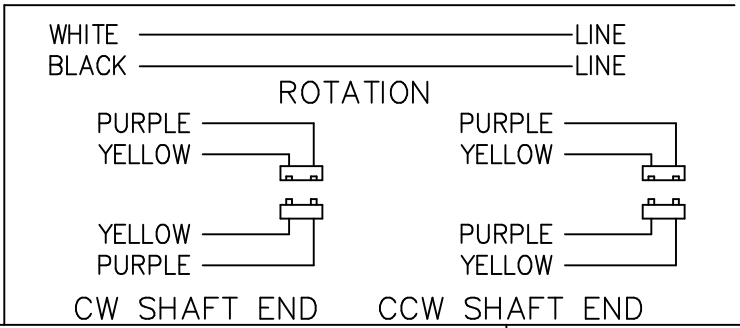

NO.	REVISION	BY & DATE	CHK	TOLERANCES UNLESS SPECIFIED	
				DEC.	INCHES
				.X	±.1
4	REVISED MOUNTING HOLE LOCATIONS	RJW 07-12-2005	ML	.XX	±.03
3	REDRAWN IN AUTOCAD	TAT 05-19-2005	ML	.XXX	±.005
2	REDRAWN ON CADD - NO CHANGE	MRB 04-01-1998		.XXXX	±.0005
				ANG	±7'30"



DRAWN MRB 03-10-1998
CHK ML 04-01-1998
APPD GK 04-01-1998
SCALE 3=8
REF
FMF
PREV

THIS DRAWING IN DESIGN AND DETAIL IS OUR PROPERTY AND MUST NOT BE USED EXCEPT IN CONNECTION WITH OUR WORK ALL RIGHTS OF DESIGN AND INVENTION ARE RESERVED THIS IS AN ELECTRONICALLY GENERATED DOCUMENT - DO NOT SCALE THIS PRINT	RFP	CAD FILE ss74126	SIZE A	DRAWING NO. SS74126	PAGE OF	REV. 4
	DIST WP					

ERROR: syntaxerror
OFFENDING COMMAND: --nostringval--

STACK:

/initialize
-dictionary-
/Pscript_WinNT_Compat
-dictionary-