

TERM. END

.185 DIA. DRAIN HOLES WITH PLUGS EACH END

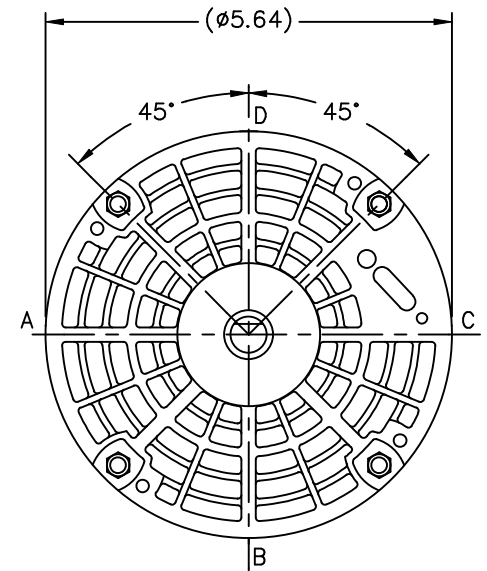
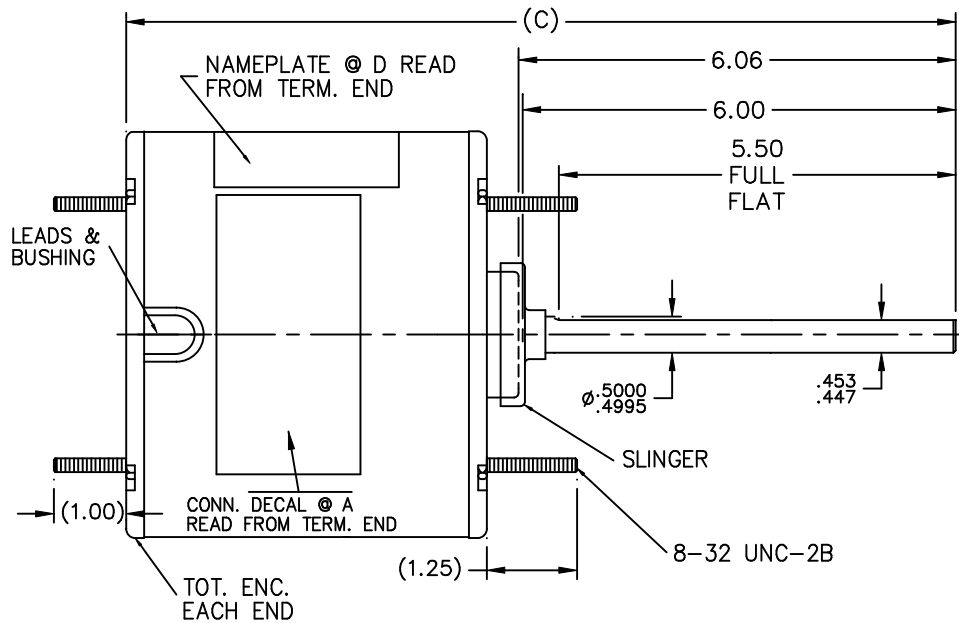
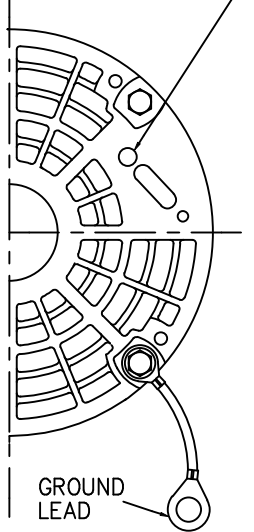

LEAD DESCRIPTION::

1 WHITE, 1 BLACK, 1 RED 30.00" LONG WITH .50 B.W.S.

1 BROWN & 1 BROWN/WHITE 30.00" LONG WITH .25 FLAG TYPE QUICK CONNECT

1 GREEN GROUND LEAD 12.00" LONG WITH TERM FOR #10 SCREW

PURPLE & YELLOW REVERSING LEADS ARE MOLDED INTO MATING PULL APART PLUGS 5.00" LONG

DASH	FR	C
350	48Y	10.50
400	48Y	11.00
450	48Y	11.50
500	48Y	12.00

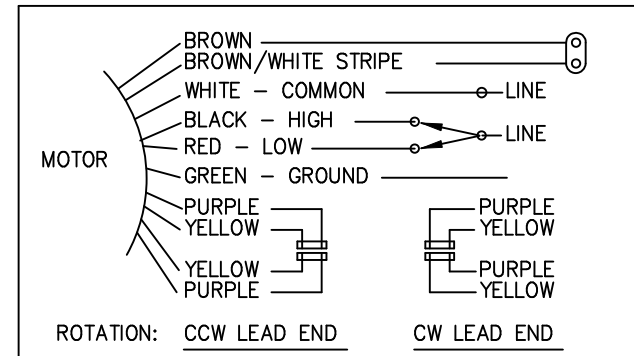

NO.	REVISION	BY & DATE	CHK	TOLERANCES UNLESS SPECIFIED	
				DEC.	INCHES
				.X	±.1
7	REVISED STUD BOLT EXTENSIONS CN 23219	BLR 01-27-1997		.XX	±.03
6	SHORTENED LEAD LENGTHS CN 21147	BLR 09-14-1995		.XXX	±.005
5	REDRAWN 3752442	RM 11-07-1990		.XXXX	±.0005
				ANG	±7'30"

MARATHON ELECTRIC

TITLE OUTLINE

MAT'L.

FINISH

DRAWN	RM 11-07-1990
CHK	ML 11-09-1990
APPD	MJB 11-13-1990
SCALE	3=8
REF	
FMF	
PREV	

THIS DRAWING IN DESIGN AND DETAIL IS OUR PROPERTY AND MUST NOT BE USED EXCEPT IN CONNECTION WITH OUR WORK ALL RIGHTS OF DESIGN AND INVENTION ARE RESERVED THIS IS AN ELECTRONICALLY GENERATED DOCUMENT - DO NOT SCALE THIS PRINT			RFP	CAD FILE ss74409	SIZE A	DRAWING NO. SS74409	PAGE OF	REV. 7
			DIST WP					