

## Lever-Operated Grease Gun

### Description

Each model gun is designed for 3-way loading; cartridge, loader pump, and suction. Refer to **Page 4** for details.

The guns are spring-primed and contain an air bleed valve to aid the priming process. Each gun is also equipped with a Loader Fitting that allows filling directly from a hand-operated loader pump. See **Figure 6**.

The Lever of the gun is adjustable. Set the gun to the volume position and operate the Lever fully to deliver 1 ounce (28.4 grams) of grease in 16 strokes. Set it to the pressure position to develop up to 10,000 psi (690 Bars). See **Figures 1 and 7**.

The gun's Lever is also variable-stroke. Grease dispenses with a stroke as short as 1/2" (12.7 mm).

These guns are designed with Buna-N (Nitrile) seals for compatibility with petroleum-based greases.

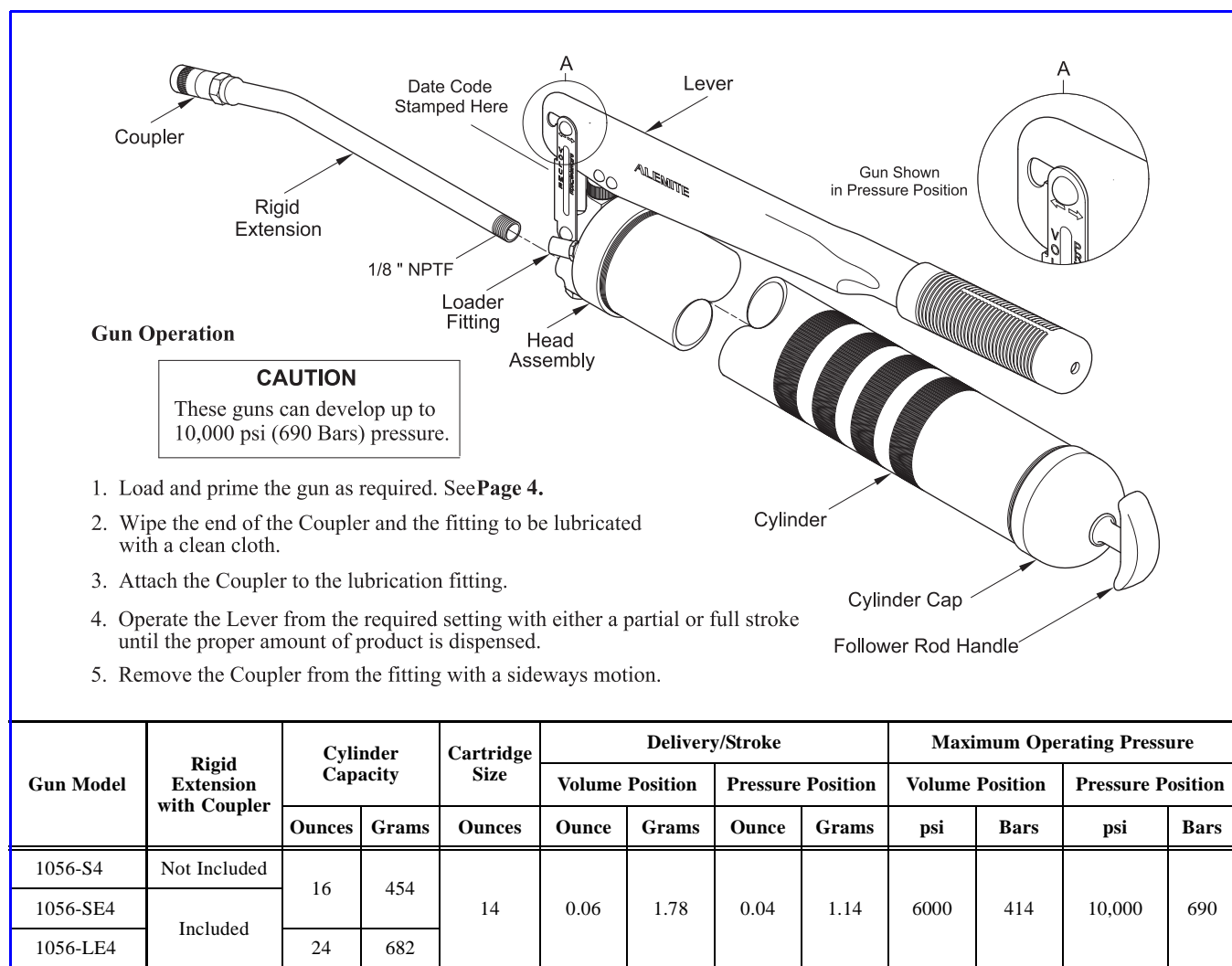

**Figure 1** Lever-Operated Grease Gun Model 1056 Series - Models 1056-SE4 and 1056-LE4 Shown

Alemite LLC  
 167 Rowland Drive, Johnson City, Tennessee 37601  
 www.alemite.com

Copyright © 2010 by Alemite LLC

This document contains confidential information that is the property of Alemite LLC and is not to be copied, used, or disclosed to others without express written permission.

SER 1056-S4  
 Revision (11-10)



Item No.	Part No.	Description	Qty	Notes	
1		Stem, Bleed Valve	1		
2		Spring	1		
4	6304-B	Coupler	1		Model 1056-S4 & 1056-SE4
5	53986	Extension	1		Model 1056-S4 & 1056-SE4
6		Head Assembly	1		
7		O-Ring, 1/8 " ID x 1/4 " OD	1		
8		Spring	1		
9		Ball, 9/32 " Dia	1		
10		Gasket (Aluminum)	2		
11		Seat, Ball	1		
12	336523	Gasket (Nitrile)	1		
13		Ball, 7/16 " Dia	1		
14		Spring	1		
15		Plug, 9/16 " -20	1		
16		Cylinder, 10-3/4 " Long	1	□	Model 1056-S4 & 1056-SE4
		Cylinder, 15 " Long	1		Model 1056-LE4
17		Pushnut	1	● □ ■	● Kit contains a quantity of 5
18		Follower (Nitrile)	1	● □ ■	● Kit contains a quantity of 5
19		Plate, Back-Up	1	● □ ■	● Kit contains a quantity of 2
20		Spring, 13-1/4 " Long	1	□	Model 1056-S4 & 1056-SE4
		Spring, 18 " Long	1	■	Model 1056-LE4
21		Cap	1	□ ■	
22		Rod and Handle (Single-Notch)	1	□	Model 1056-S4 & 1056-SE4
23		Rod and Handle (Double-Notch)	1	■	Model 1056-LE4
24	B322610	Fitting Assembly, Loader	1		
<b>Legend:</b> Part numbers left blank are not available separately ● □ ■ designates a repair kit item					

### Repair Kits

Part No.	Kit Symbol	Description
<b>393604</b>	●	Kit, Repair, Follower [Contains five (5) of items 17 and 18 and two (2) of item 19]
339820	□	Kit, Cylinder (Assembled) [for models 1056-S4 and 1056-SE4]
393525	■	Kit, Follower (Assembled) [for model 1056-LE4]

## Loading the Gun

*IMPORTANT: Warranty may be void if these procedures are not explicitly followed.*

### Cartridge Loading

1. Unscrew the Head Assembly from the Cylinder.
2. Pull the Follower Rod outward from the Cylinder Cap.
3. Engage the groove\* in the Follower Rod with the slot in the Cylinder's Cap. See **Figure 3**.
4. Remove the plastic cap from the cartridge and discard.
5. Apply a film of grease to the exposed inside surface of the cartridge.

**NOTE:** This is only necessary for a virgin gun.

6. Insert the cartridge into the Cylinder (open end first) until the metal lip seats.
7. Remove the tabbed seal from the cartridge and discard.
8. Screw the Head Assembly onto the Cylinder.
  - Tighten the Head Assembly securely to the Cylinder.
9. Disengage the Follower Rod from the slot in the Cylinder's Cap.
10. Push and rotate the Follower Rod into the Cylinder.
11. Prime the gun. Refer to the section entitled **Priming the Loaded Gun** for details.

### Loading the Gun from a Loader Pump

#### WARNING

**The gun is equipped with a low-pressure Loader Fitting. Do not substitute with a high-pressure grease fitting. Personal injury can occur due to excessive pressure.**

**The use of a grease fitting will void the warranty.**

1. Wipe the Loader Fitting with a clean cloth.

\* Engage the first groove on Model 1056-LE4. The second groove is used when filling from a loader pump or suction loading.

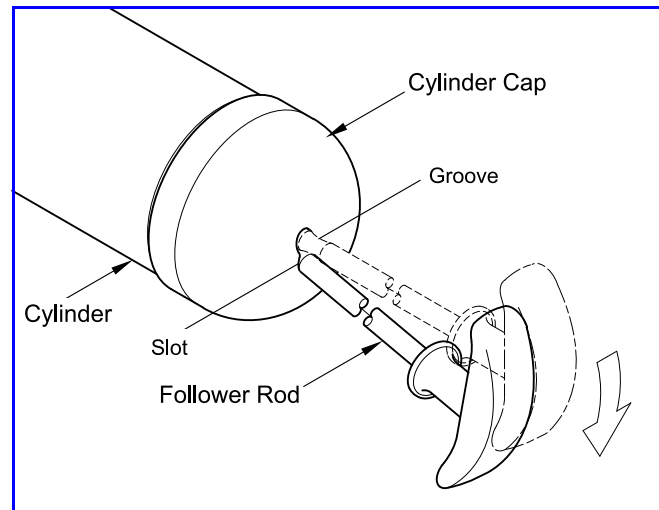
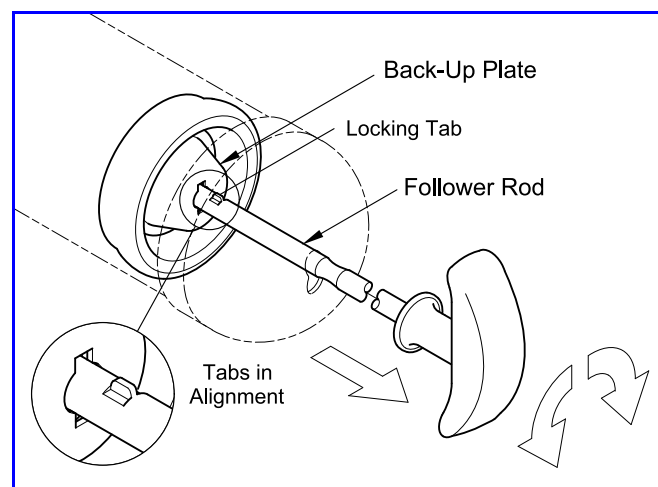

**Figure 3** Follower Rod Engaged in Cylinder Cap Slot

#### CAUTION

**The Loader Fitting on the gun must mate with the loader coupler. The pump may not operate if the components are not compatible.**

2. Pull the Follower Rod outward from the Cylinder Cap. At the same time, rotate the Rod to allow the Locking Tabs access through the Back-Up Plate. See **Figure 4**.
3. Rotate the Rod and allow the Locking Tabs to contact the Back-Up Plate. See **Figure 5**.
4. Remove the cap on the pump's loader coupler.
5. Seat the Loader Fitting into the loader coupler. See **Figure 6**.



**Figure 4** Follower Rod Locking Tabs Aligned with Back-Up Plate

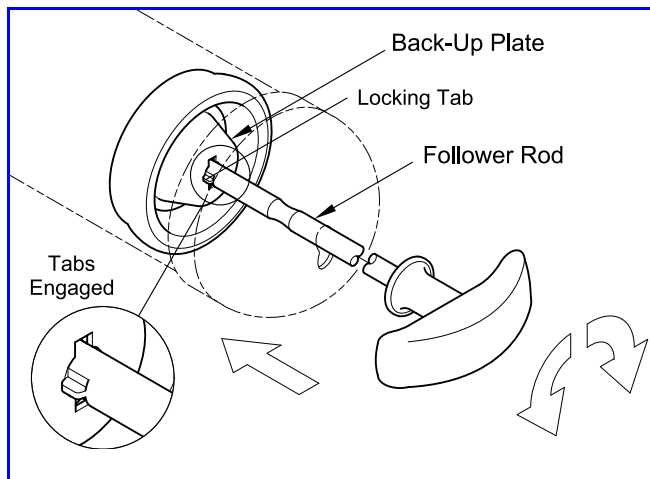

**Figure 5** Follower Rod Engaged with Back-Up Plate

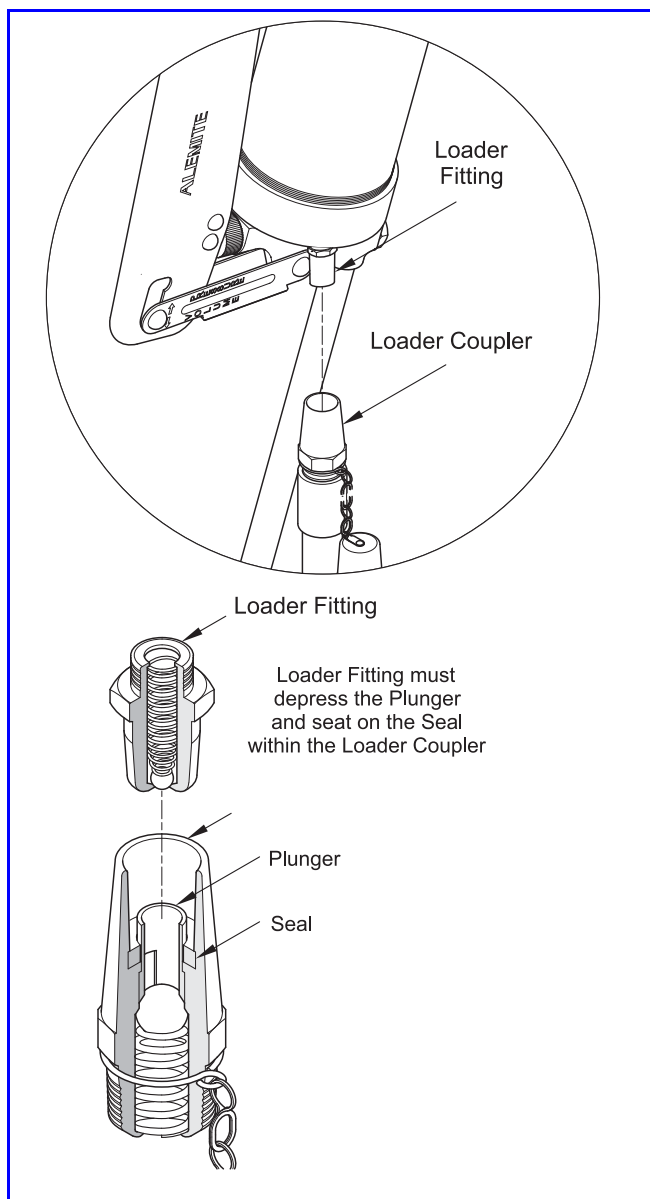

**Figure 6** Loader Fitting and Loader Coupler  
Section View

6. Operate the pump and view the movement of the Follower Rod.
7. Discontinue pump operation once the groove\* on the Follower Rod is visible.
8. Push and turn the Follower Rod into the Cylinder.
9. Prime the gun. Refer to the section entitled **Priming the Loaded Gun** for details.

## Suction Loading

1. Unscrew the Head Assembly from the Cylinder.
2. Insert the head of the Cylinder below the surface of the grease.
3. Slowly pull the Follower Rod outward from the Cylinder Cap until the groove\* is visible.
4. Engage the groove in the Follower Rod with the slot in the Cylinder's Cap. See **Figure 3**.
5. Screw the Head Assembly onto the Cylinder.
  - Tighten the Head Assembly securely.
6. Push and rotate the Follower Rod into the Cylinder.
7. Prime the gun. Refer to the section entitled **Priming the Loaded Gun** for details.

## Priming the Loaded Gun

### Overview

Priming is the act of removing air and introducing grease into the gun's pumping mechanism.

Whether a gun primes is dependent on the:

- viscosity of the grease
- temperature of the grease
- condition of the gun

### Operate the Gun

*IMPORTANT: Make sure the gun is in the volume position. See **Figure 7**.*

In most cases the gun will prime simply by operating the Lever several times.

Should grease fail to appear, the Head Assembly must be bled.

\* Locate the second groove on model 1056-LE4.

## Force Prime

This process manually assists air within the Head Assembly to be bled at the Bleed Valve.

1. Make sure the Lever is in the volume and open position.
2. Pull the Follower Rod outward from the Cylinder Cap. At the same time, rotate the Rod to allow the Locking Tabs access through the Back-Up Plate. See **Figure 4**.
3. Rotate the Rod and allow the Locking Tabs to contact the Back-Up Plate. See **Figure 5**.
4. Depress the Bleed Valve and at the same time push the Follower Rod into the gun's Cylinder. See **Figure 7**.

Once the air is eliminated:

5. Operate the Lever of the gun several times.

Once grease appears:

6. Push and turn the Follower Rod into the Cylinder.

## Loss of Prime

A situation may arise when only a portion of the grease within the gun dispenses.

The most common cause for this loss of prime is due to an air pocket in the grease.

The reasons previously stated as to whether a gun primes are additional conditions that can cause a loss of prime:

- viscosity of the grease
- temperature of the grease
- condition of the gun

Additional conditions are:

- damaged cartridge
- type of grease \*

\* Certain synthetic greases can react with the follower causing it to swell.

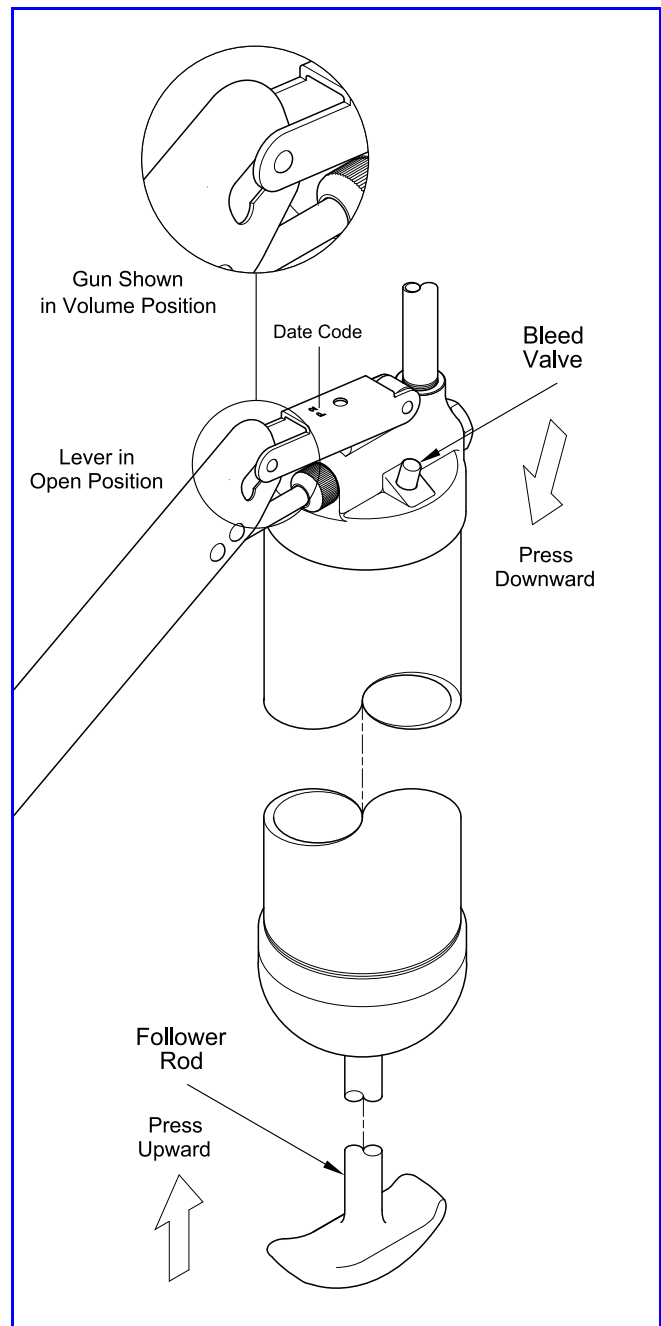

**Figure 7** Force Priming the Gun

### Changes Since Last Printing

Updated repair parts and kits