

COMPONENT LIST

ITEM NO.	DESCRIPTION	MAT'L	COMPONENT NO.	QTY.
1	STRAND	SST	304-01-003	-
2	EYE	SST	304-46-078	2
3	EQUALIZER	SST	304-48-007	2
4	TAG	MYLAR	309-77-0602	1

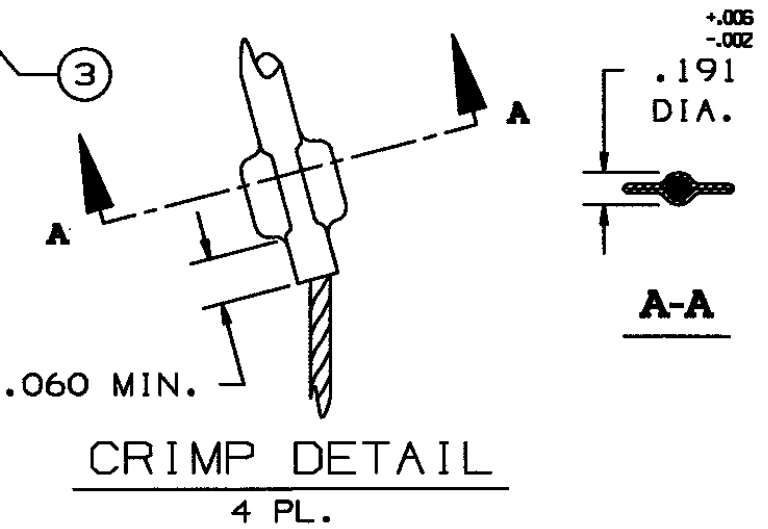
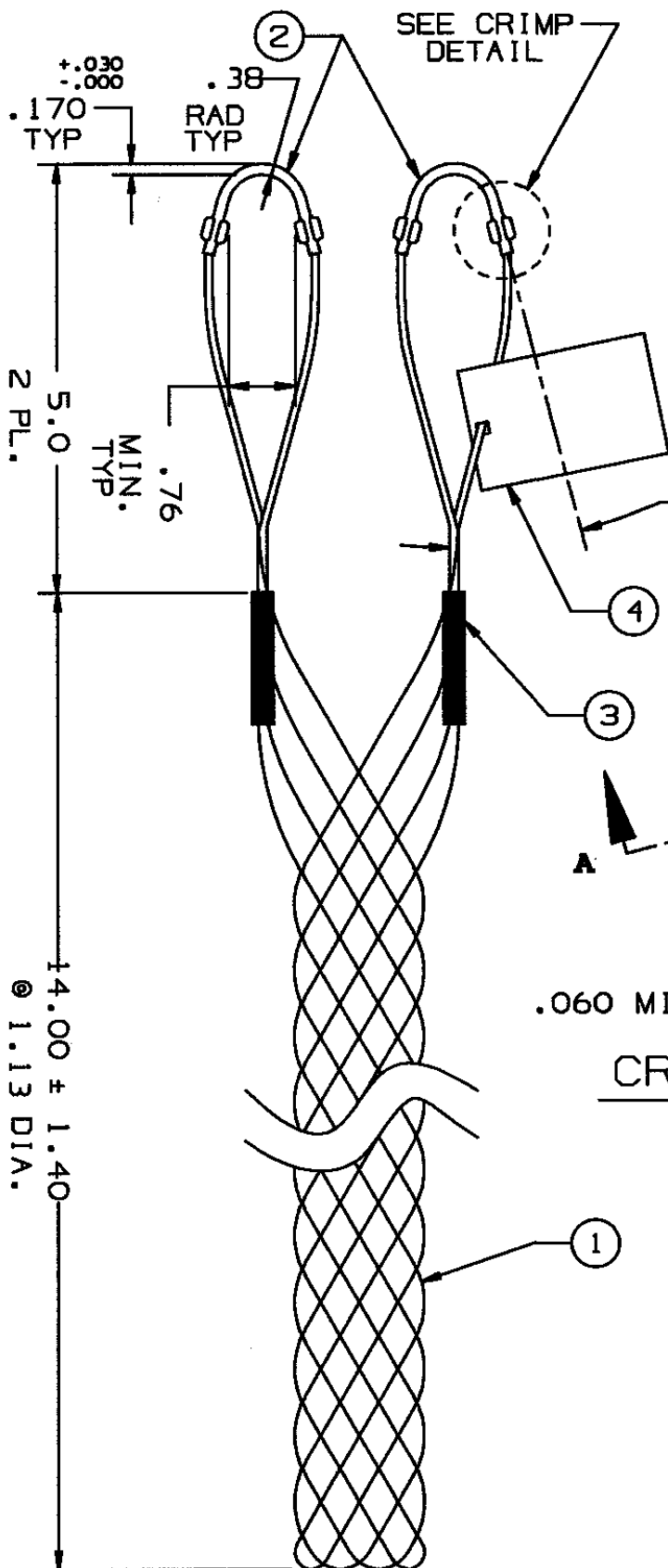

IN ACCEPTING OUR DRAWINGS OR BLUEPRINTS FOR QUOTATION OR OTHER PURPOSES, YOU AGREE NOT TO DISCLOSE TO OTHERS THE IDEAS, INFORMATION, OR DESIGNS THEREIN SHOWN, AND THAT YOU WILL MAKE NO USE OF OUR DRAWINGS OR BLUEPRINTS OR OF THE IDEAS, INFORMATION, OR DESIGNS THEREIN SHOWN WITHOUT OUR PERMISSION.

TITLE GRIP, STD, SUPPORT, CLOSED MESH
SINGLE WEAVE, DOUBLE "U" EYE
DIA. RA. 1.00-1.24
APPROX. BRK. STR. 2670# ±20%

TOLERANCES UNLESS OTHERWISE SPECIFIED .X = ±.5 .XX = ±.05 .XXX = ±.015 ANGLE TOL. ± 2°	HUBBELL INCORPORATED KELLEMS DIVISION STONINGTON, CT	
	DR. BY FBR	APP. BY FFS
PROJECT NO.	TR. BY	SCALE N/A
	CHK. BY FFS	DATE 12-15-93

DR. NO. **024-01-005** REV. **L**

SHEET 1 OF 1