

M-8240 2

NOTE:

1. THIS DIMENSION VARIABLE
DEPENDENT UPON CORD DIA.

2. INCHES [mm]

CATALOG NO.	CORD DIA. GRIP RANGE		"A" DIM. MAX.	"B" DIM. MAX.	"C" DIM. MAX.
	INCHES	[mm]	INCHES [mm]	INCHES [mm]	INCHES [mm]
074 PG21 010	.500	[12.7]	1.145 [29.1]	5.290 [134.4]	.590 [134.4]
	.625	[15.9]			
074 PG29 021	.625	[15.9]	1.770 [44.9]	6.790 [172.5]	.628 [172.5]
	.750	[19.0]			
074 PG29 023	.750	[19.0]	1.770 [44.9]	6.990 [182.6]	.628 [172.5]
	.875	[22.2]			
074 PG29 025	.875	[22.2]	1.770 [44.9]	7.190 [182.6]	.628 [172.5]
	1.000	[25.4]			
074 PG36 028	1.125	[28.6]	2.325 [59.0]	6.705 [170.3]	.651 [16.5]
	1.250	[31.6]			

CATALOG NO.	"D" DIM. MAX.	"E" THD.	"F" DIM. MAX.	"G" DIM. MAX.
	INCHES [mm]		INCHES [mm]	INCHES [mm]
074 PG21 010	1.25 A/F	PG21 PER DIN 40430	1.000 [25.4]	.200 [5.0]
074 PG29 021	1.625 A/F	PG29 PER DIN 40430	1.270 [32.2]	.220 [5.6]
074 PG29 023	1.625 A/F	PG29 PER DIN 40430	1.270 [32.2]	.220 [5.6]
074 PG29 025	1.625 A/F	PG29 PER DIN 40430	1.270 [32.2]	.220 [5.6]
074 PG36 028	2.25 A/F	PG36 PER DIN 40430	1.400 [35.6]	.243 [6.2]

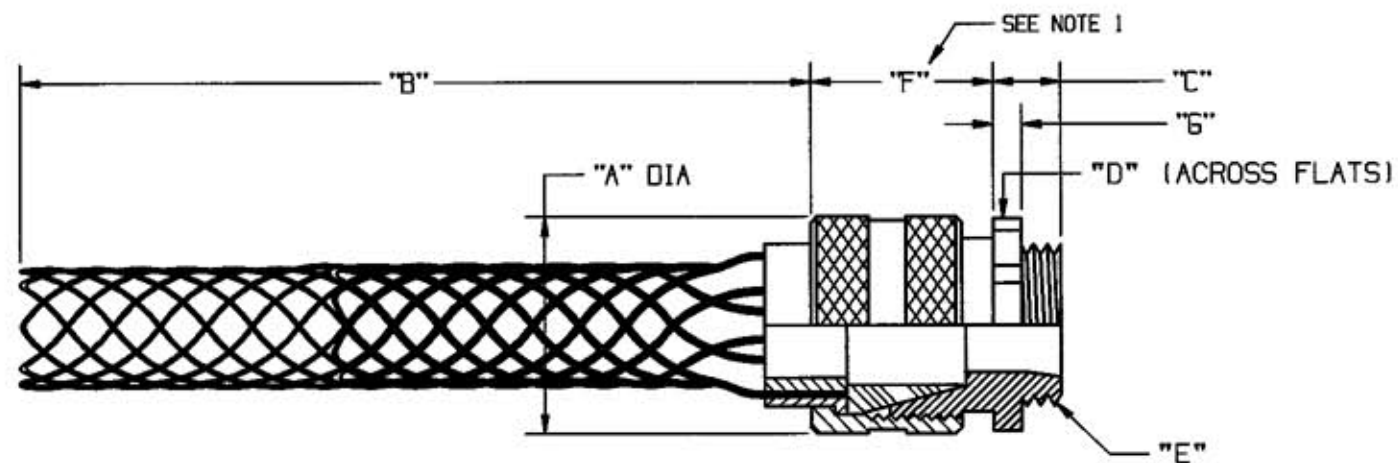

LIST OF PARTS

DESCRIPTION	MATERIAL	FINISH
NIPPLE	ALUMINUM	
NUT	ALUMINUM	
BUSHING	NEOPRENE	
GRIP BRAID	STEEL	GALVANIZED

DIMENSION SHEET FOR CAT. NO. SEE TABLE

REPAIRABLE NON-REPAIRABLE B

SYM	REVISIONS	APP	DATE
2	1/21/02 ADDED METERIC VALUES TO DIM'S IN TABLE. ADDED NOTE 2. ROTATED GRIP VIEW. PER DCN 8696 SPN	TCM [Signature]	2/6/02
1	INITIAL RELEASE DCN. 6924	JAH	7/8/99

THE DESIGN AND DIMENSIONS OF THE PRODUCT SHOWN ON THIS DRAWING ARE SUBJECT TO CHANGE WITHOUT NOTICE

TITLE
LIQUID-TIGHT SR GRIPS,
PG THREAD

TOLERANCES UNLESS OTHERWISE SPECIFIED FRACTIONS ± 1/64 DECIMALS ± .005 ANGLES ± 2°	WIRING DEVICE-KELLEMS HUBBELL INCORPORATED BRIDGEPORT, CT	
	DR. BY T.J.V.	APP. BY JAH
	TR. BY	SCALE NONE
	CHK'D BY JAH	DATE 6-30-99

M-8240

2