

KOP-GRID® Tapered Grid Coupling - Type H Horizontal Split Cover

Installation and Alignment
Instructions
FORM 17200
DECEMBER, 1996

KOP-FLEX®
Emerson Power Transmission

KOP-FLEX, INC., P.O. BOX 1696, BALTIMORE MARYLAND 21203, 410-768-2000
KOP-FLEX CANADA, LTD., 19 METEOR DRIVE, REXDALE, ONTARIO, CANADA M9W-1A3, 416-675-7144

⚠ CAUTION
If assembled incorrectly, equipment failure and personal injury may result.

⚠ WARNING
Do not operate without guards. Turn off power to install or service.

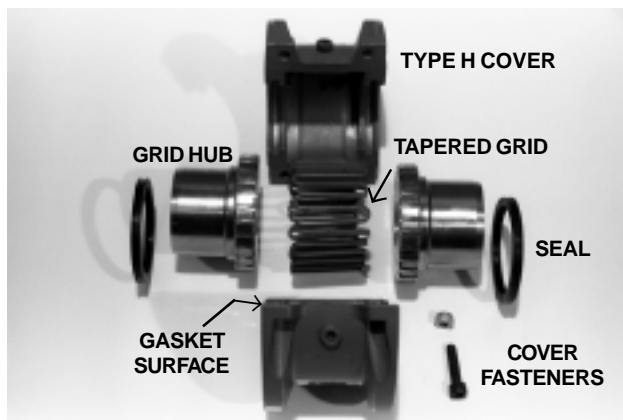

INSTALLATION and ALIGNMENT INSTRUCTIONS

These instructions apply to KOP-GRID® type H tapered grid couplings.

This sheet may be supplemented by Special Instructions supplied with the coupling for modifications and variations of these couplings. For dimensions, ratings, maximum bores, interference fits, and other technical information, please refer to Bulletin 1700.

When working on rotating equipment be sure to lock out the starting switch of prime mover so the equipment cannot be started until work is complete, checked, and personnel are safely away. Proper installation per this product instruction sheet must be observed. Failure to do so may void warranty and could result in injury to person or property.

MAINTENANCE and LUBRICATION

Lubricate the KOP-GRID® coupling with grease only. Use KOP-FLEX® KSG coupling grease or other grease meeting the minimum specifications shown.

Do not use oil in KOP-GRID® couplings.

Coupling lubrication is critical. The use of proper and sufficient lubrication is part of a successful installation.

Lubricants should be checked to ensure the proper level is maintained and that the lubricant is free of contaminants. In an average industrial application, the coupling should be checked for lubricant contamination and replenished with the proper volume every twelve months. Conditions such as very slow speed, reversing drives, high heat and severe environments may require more frequent lubrication.

RECOMMENDED LUBRICANT KOP-FLEX® KSG Coupling Grease

This grease is specifically compounded for standard couplings to provide improved lubrication and resistance to centrifugal separation. When KSG grease is used, lubrication intervals may be extended, based upon operating experience. KSG coupling grease is available from Kop-Flex or authorized distributors of Kop-Flex power transmission products.

OTHER GREASES

Alternate lubricating greases should equal or exceed the specifications for KOP-FLEX® KSG coupling grease (specification sheet 3532 is available upon request). Greases other than KSG should meet these minimum specifications:

Grade: NLGI #1
Base oil Viscosity: Min:
3000 SSU at 100°F
160 SSU at 210°F

Dropping Point, Min.: 190°F
Four Ball Wear, ASTM D-2266:
.500 mm Maximum

Base Oil Content: 87% Minimum
K36 Factor, ASTM D-4425:
KSG: K36 = 8/25 = .33

Required:
Rust and Oxidation Inhibitors
E.P. Additives

KOP-FLEX®
Emerson Power Transmission

⚠ WARNING Disconnect all power while adjusting units

The most reliable test of a suitable lubricant is often the result of user experience and satisfaction. If a lubricant has been known to sludge, separate into heavy components or dry out, consider the use of KOP-FLEX® KSG grease.



Important Safety Instructions

Before start-up . . . for reasons of safety and to extend shaft coupling life, follow these requirements.

1. Coupling guards protect personnel. **ALL COUPLINGS MUST BE COVERED WITH A GUARD AS PER OSHA REQUIREMENTS.**
2. Recheck alignment after all foundation bolts and mechanical connections are tightened.
3. Make sure all fasteners are properly installed and tightened.
4. Take the time to double check your work.
5. Only authorized Kop-Flex replacement parts are to be used.
6. Call Kop-Flex for any clarification or questions.

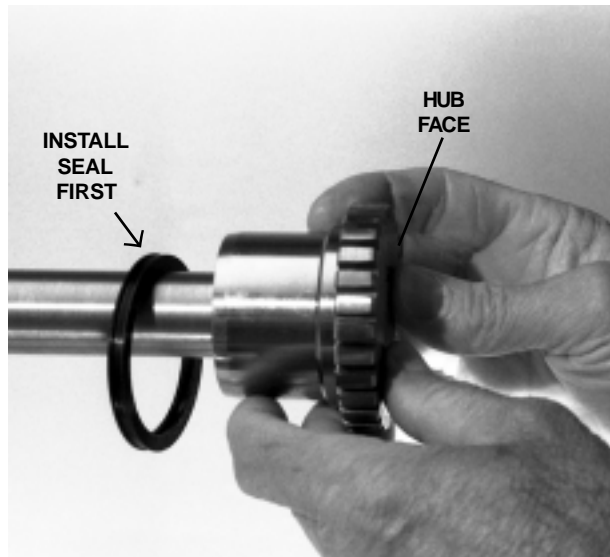

Figure 1

1. HUB INSTALLATION

Verify all parts are on hand and are as ordered, check that the hub bores are correct. Prepare shafts by removing dirt and burrs. Lightly apply grease on seals and place them on shafts, before installing the hubs. Mount the hubs on their shafts, with hub face flush with the shaft end. Properly tighten setscrews when furnished. For vertical shafts, seal the key-

way to prevent grease leakage. For interference fit, heat the hub in an oven to 300°F (150°C) before mounting the hub. **NEVER** exceed 600°F (300°C).

Note: Allow heated hubs to cool to room temperature before coupling alignment and assembly.

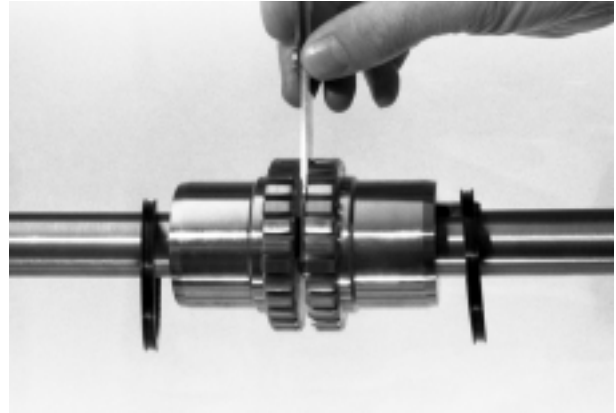

Figure 2

2. SHAFT SEPARATION & ANGULAR ALIGNMENT

Use a feeler gauge to measure the gap between hub faces at 4 points 90° apart. The gap should not exceed the value specified in Table 1. Position equipment to obtain best alignment. The measured difference between minimum and maximum value should not exceed the angular limit specified in Table 1.

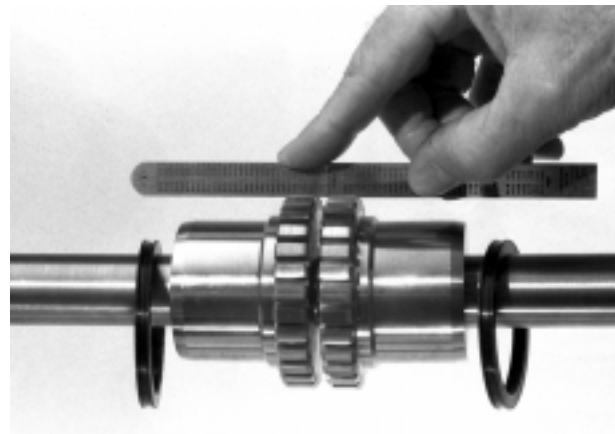

Figure 3

3. OFFSET ALIGNMENT

Use a straight edge and feeler gauge to align shafts at 4 points 90° apart. The offset (parallel misalignment) should not exceed the offset limit specified in Table 1.

Adjust equipment as required. Recheck steps 2 and 3 after tightening the foundation bolts and realign the coupling, if the offset and angular measurements exceed the values in Table 1. Note: Best coupling alignment is obtained by using dial indicators. If dial indicators are used, always rotate the hub on which the indicator is mounted to obtain readings.

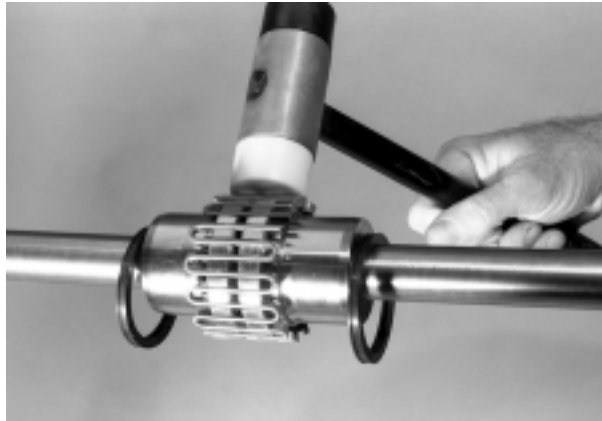

Figure 4

4. TAPERED GRID INSTALLATION

Fill the hub gap and grid teeth grooves with KOP-FLEX® KSG grease or a comparable alternate. Lightly open the grid to engage with the grooves on the hub. Use a soft mallet to seat the grids in the tapered teeth grooves. For tapered grids that are supplied with more than one segment, make sure all the segment's open ends are on the same side.

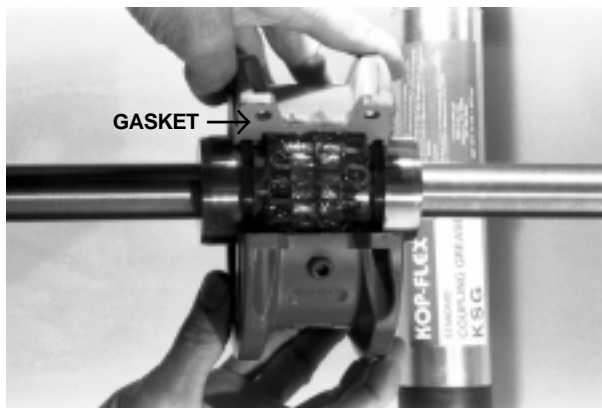

Figure 5

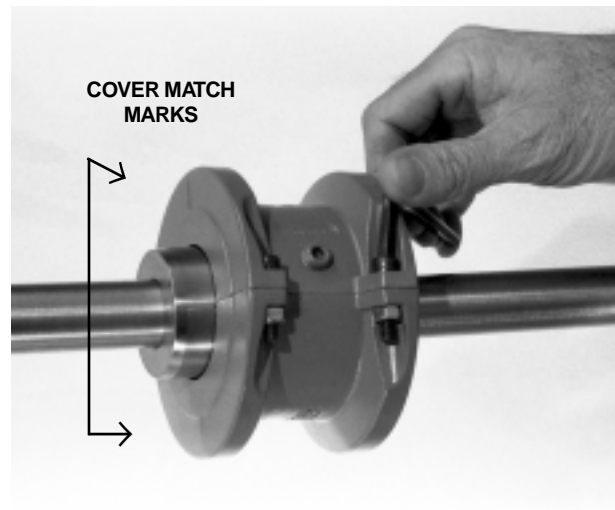

Figure 6

5. COVER INSTALLATION & LUBRICATION

Pack the grid with additional KSG grease or the equivalent and wipe off the excess flush with the top of the grid. Slide seals over the hub and adjust to line up with the cover seal grooves. Place gaskets on both flanges of the lower cover and install top cover. Align cover match marks on the same side. For vertical applications or inclined shafts, make sure the match marks are UP, or on the higher side. Tighten the cover fasteners to the cover bolt torque value specified in Table 1. For lubrication, remove the two lube plugs from the covers and fill with KOP-FLEX® KSG grease or specified alternate, until the grease starts seeping out from the other lube hole. Re-install the two lube plugs in the covers and tighten securely.

Note: Do not operate coupling without the lube plugs.



WARNING Disconnect all power while adjusting units

KOP-FLEX®

Emerson Power Transmission

GRID REMOVAL:

Remove the coupling cover assembly. Insert a rod or screw driver into the open end loop of the tapered grid. Use the teeth on the coupling hub as a support to gradually and gently pry off the grid, proceeding alternately from side to side.

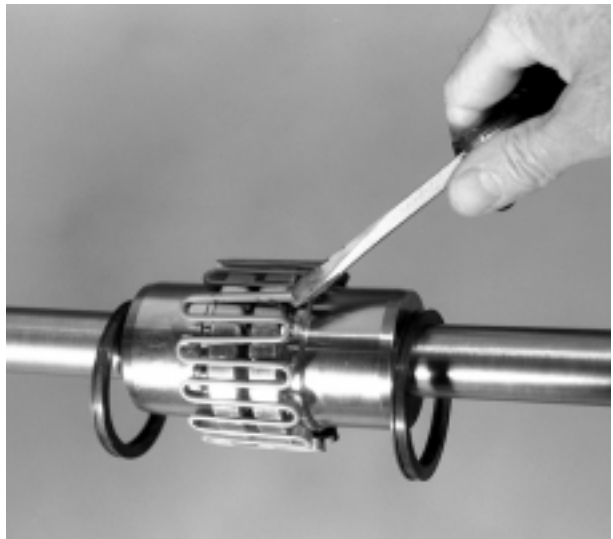

Figure 7

Table 1

INSTALLATION AND ALIGNMENT VALUES						
SIZE	MAXIMUM RECOMMENDED MISALIGNMENT LIMITS		GAP (IN.)	COVER BOLT TORQUE (LB-IN.)	ALLOWABLE MAXIMUM SPEED (RPM)	LUBE/GREASE WEIGHT (LB.)
	OFFSET (IN.)	ANGULAR (IN.)				
1020	0.006	0.003	0.125	100	4,500	0.07
1030	0.006	0.003	0.125	100	4,500	0.07
1040	0.006	0.003	0.125	100	4,500	0.11
1050	0.008	0.004	0.125	200	4,500	0.11
1060	0.008	0.005	0.125	200	4,350	0.20
1070	0.008	0.005	0.125	200	4,125	0.24
1080	0.008	0.006	0.125	200	3,600	0.37
1090	0.008	0.007	0.125	200	3,600	0.55
1100	0.010	0.008	0.188	260	2,440	0.95
1110	0.010	0.009	0.188	260	2,250	1.12
1120	0.011	0.010	0.250	650	2,025	1.61
1130	0.011	0.012	0.250	650	1,800	2.00
1140	0.011	0.013	0.250	650	1,650	2.50