

INSTRUCTION MANUAL FOR DODGE® No. 11 D, 11 DL & 15D FLEXIDYNE DRIVE

These instructions must be read thoroughly before installation or operation.

WARNING: To insure that drive is not unexpectedly started, turn off and lock out or tag power source before proceeding. Failure to observe these precautions could result in bodily injury.

DESCRIPTION

FLEXIDYNE dry fluid couplings are a unique concept to provide soft start and momentary overload protection for all types of driven equipment. Standard NEMA-B motors with RPM base speeds of 1750, 1160 or 860 are commonly used with a FLEXIDYNE, yet other available power sources may be used with the FLEXIDYNE.

The dry "fluid" in the FLEXIDYNE is heat treated steel shot. A measured amount, referred to as flow charge, is added into a housing which has been keyed to the motor shaft. When the motor is started, centrifugal force throws the flow charge to the perimeter of the housing, packs it between the housing and the rotor which in turn transmits power to the load.

After the starting period of slippage between housing and rotor the two become locked together and achieve full load speed, operating without slip and with 100% efficiency.

Consequently, the motor accelerates instantly to base speed, while the load starts gradually and smoothly.

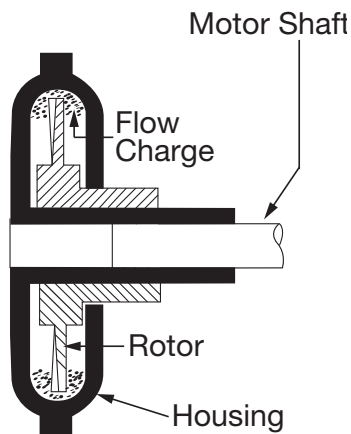

Figure 1 - Flexidyne Coupling

WARNING: Because of the possible danger to persons(s) or property from accidents which may result from the improper use of products, it is important that correct procedures be followed: Products must be used in accordance with the engineering information specified in the catalog. Proper installation, maintenance and operation procedures must be observed. The instructions in the instruction manuals must be followed. Inspections should be made as necessary to assure safe operation under prevailing conditions. Proper guards and other suitable safety devices or procedures as may be desirable or as may be specified in safety codes should be provided, and are neither provided by Dodge nor are the responsibility of Dodge. This unit and its associated equipment must be installed, adjusted and maintained by qualified personnel who are familiar with the construction and operation of all equipment in the system and the potential hazards involved. When risk to persons or property may be involved, a holding device must be an integral part of the driven equipment beyond the speed reducer output shaft.

INSTALLATION

Install sheave on driven hub using screws and lockwashers furnished. Torque screws to 580 inch-pounds. Do not use sheaves with set screws that exert pressure on the driven hub; they may distort the driven hub and damage the needle bearing. Slide the FLEXIDYNE Drive on the motor shaft with collar as close to motor as possible. Tighten key set screw securely against motor shaft key. Tighten shaft set screw against motor shaft. Note that drive hub must be installed on the motor shaft (or on other installations it must be the first part of the FLEXIDYNE to receive power from the power source) to permit proper operation of the FLEXIDYNE Drive.

START-UP

1. The flow charge recommended in Table 1 is the amount per cavity required. To assure a more even initial distribution of flow charge, remove filler plugs and pour $\frac{1}{2}$ of recommended amount in both cavities. Replace filler plugs being careful to clear threads of any flow charge. Manually rotate the FLEXIDYNE housing several turns. Remove filler plugs and pour in remaining amount of flow charge. Clear threads as before, replace filler plugs and torque to 200 in.-lbs. on sizes 11D & 11DL; 700 in.-lbs on size 15D.
2. Attach AC ammeter (conventional clamp-on or equivalent) to one line of the AC motor. Set range to cover 200% of motor nameplate current.
3. Note maximum allowable acceleration time for FLEXIDYNE as stated in Tables 1 and 2. Note: Table 2 lists starting time capacity for starting cycles occurring more than once every 2 hours.
4. Push start button. Observe motor current during load acceleration and number of seconds required to reach full speed.

Increase amount of flow charge if:

- A. Acceleration time reaches maximum allowable before load is up to speed. Turn off power immediately if this time is reached.
- B. Acceleration amperage is below motor nameplate

Decrease amount of flow charge if:

- A. Acceleration time is less than $1\frac{1}{2}$ seconds.
- B. Acceleration amperage is above 200% of motor nameplate.

CAUTION: The FLEXIDYNE rotor must slip during acceleration to allow flow charge to become evenly distributed in the FLEXIDYNE housing. There-fore, DO NOT ALLOW FLEXIDYNE MECHANISM TO RUN "FREE" (that is, without a load on the driven end), otherwise an out-of-balance condition may result, damaging mechanism.



The amount of flow charge in the FLEXIDYNE determines the acceleration time for a given load. Longer acceleration times will occur when less flow charge is used and faster acceleration, from stop to full speed, will be observed with greater amounts of flow charge.

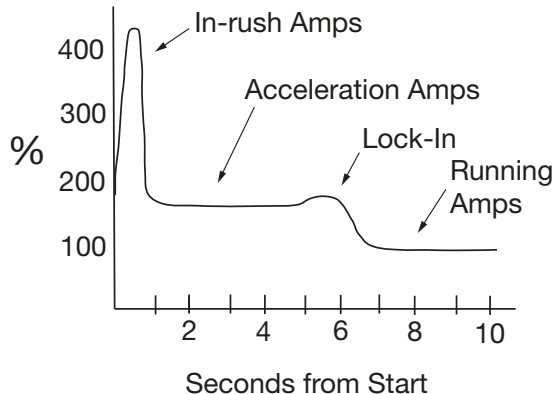

Figure 2 - Flow Charge

OPERATION

The FLEXIDYNE should start the load smoothly and without delay provided the proper amount of flow charge has been used. Should the acceleration time exceed the maximum allowable in Table 1, shut off power to the FLEXIDYNE immediately. Allow the FLEXIDYNE to cool, then add small amounts of flow charge until proper acceleration is observed.

Vibration is an indication of accelerating too rapidly and not allowing flow charge to become evenly distributed in the FLEXIDYNE housing. This can be corrected by removing small amounts of flow charge until vibration subsides. Other causes of vibration are, undersize shafting, unit not installed far enough on shaft or worn bore in the unit.

Slippage – The FLEXIDYNE can, without slipping, transmit overloads up to 130% of its present starting torque. Should this breakaway torque be exceeded the FLEXIDYNE will slip and generate heat (see Overload Protection). Although slippage usually indicates increased loads, it can also be caused by worn flow charge or a worn rotor especially if the FLEXIDYNE has been in operation for some time. The necessity to replace either a rotor or flow charge will be made evident by a loss in power transmitting capacity of the FLEXIDYNE.

MAINTENANCE

For average industrial applications involving 3 or 4 starts a day of not more than 6 seconds acceleration time each, the flow charge should be changed every 10,000 hours of operation. For more severe conditions, visually inspect flow charge at more frequent intervals; it should be changed when it has deteriorated to a half powder, half granular condition. Visual inspections should continue until enough flow charge changes have been made to adequately establish a schedule for renewing FLEXIDYNE flow charge.

The FLEXIDYNE has been lubricated at the factory and no further lubrication is required. Never apply grease, oil or any other foreign material to the flow charge.

THERMAL CAPACITY

Since there is slippage within the flow charge during acceleration, heat is generated from friction. The thermal capacity of the FLEXIDYNE is based on balancing this heat generated during acceleration against the cooling time between accelerations. The amount of heat generated is determined by the amount of horsepower dissipated by slipping and the duration of each acceleration. If the flow charge weight is light, the heat generated will not be as great as that which would be generated with a heavier flow charge, when compared at the same acceleration time. A longer time between starts will dissipate more heat; therefore, higher starting horsepowers may be transmitted, or longer acceleration times may be allowable. (See Starting Cycle) Acceleration times shown in Table 1 are for starting frequencies of one start per hour or less. If starting frequency is more than once per hour, use acceleration time for actual starting cycle shown in Table 2.

Acceleration times listed in Tables 1 and 2 are the MAXIMUM permissible for the various starting frequencies listed. The MINIMUM acceleration time required for proper FLEXIDYNE operation is 1 to 1½ seconds. This is the time required for the flow charge to be uniformly distributed around the housing cavity before the unit “locks in”. Any acceleration time between the minimum and maximum listed is acceptable, although a shorter acceleration time will generally provide longer wear life. For applications requiring a specific acceleration time (within these limits) flow charge may be added or removed to produce the required results.

Stalled – If a jam-up stalls the drive, the motor continues to run and the FLEXIDYNE slips. This causes heat to be generated at twice the rate of normal acceleration. Therefore, the allowable slipping time, when stalled, is half the allowable acceleration time given in Table 1.

Starting Cycle is the time from the beginning of one acceleration to the beginning of the next. Allowable acceleration times in Table 2 are based on the assumption that the FLEXIDYNE will be running continuously except for a momentary stop before the next start. If the stop is more than momentary, decrease the actual starting cycle by one-half the stopped time before using Table 2; for example, with a 50 minute actual starting cycle of which 20 minutes is stopped time, decrease 50 by half of 20 to give 40 minutes as the starting cycle time to use for Table 2.

Grouped Starts – For several starts grouped together followed by uninterrupted running, add the acceleration times of all starts and consider it as the time for one start. The starting cycle would be the time from the beginning of one group of starts to the beginning of the next group.

Table 1 - Flow Charge Recommendations for FLEXIDYNE Drive

Based on % Starting Torque for 1760 RPM NEMA Design B Motors		100% @ 1760 RPM			125% @ 1750 RPM			150% @ 1740 RPM			175% @ 1700 RPM			200% @ 1650 RPM					
		Rated Motor HP	Starting HP	Max. Time In Sec	Starting HP	Flow Charge Lbs	Flow Charge Oz	Max. Time In Sec	Starting HP	Flow Charge Lbs	Flow Charge Oz	Max. Time In Sec	Starting HP	Flow Charge Lbs	Flow Charge Oz	Max. Time In Sec			
11D & 11DL	25	25	98	31	4	5	76	37	4	13	55	42	5	8	42	6	2	37	
	30	30	80	37	4	13	55	45	5	8	39	51	6	3	33	6	12	27	
	40	40	44	50	5	14	34	60	6	8	24	68	7	3	22	8	0	19	
	50	50	34	62	6	10	24	74	7	6	20	85	8	2	17	8	11	15	
	60	60	31	75	8	3	25	89	9	1	20	102	10	1	16	10	14	15	
15D	75	75	25	94	9	3	18	111	10	3	15	127	11	0	13	141	12	0	12
	100	100	16	125	10	10	13	149	11	9	11	170	12	8	9	188	13	5	8

Based on % Starting Torque for 1175 RPM NEMA Design B Motors		100% @ 1175 RPM			125% @ 1160 RPM			150% @ 1150 RPM			175% @ 1130 RPM			200% @ 1100 RPM					
		Rated Motor HP	Starting HP	Max. Time In Sec	Starting HP	Flow Charge Lbs	Flow Charge Oz	Max. Time In Sec	Starting HP	Flow Charge Lbs	Flow Charge Oz	Max. Time In Sec	Starting HP	Flow Charge Lbs	Flow Charge Oz	Max. Time In Sec			
11D & 11DL	10	10	480	12.4	4	13	439	14.8	5	10	398	17	6	3	360	19	7	0	325
	15	15	394	18	6	5	343	22	7	0	274	25	7	14	222	28	9	0	171
	20	20	308	25	7	14	222	30	8	4	136	34	8	13	125	38	9	10	113
	25	25	198	31	9	13	161	37	10	12	124	42	11	13	100	47	12	10	88
	30	30	167	37	10	10	124	44	11	11	96	51	12	9	79	57	13	8	64
15D	40	40	105	50	12	14	81	59	13	0	58	68	14	0	49	75	15	3	43
	50	50	81	62	13	1	54	74	14	2	44	85	15	8	36
	60	60	56	75	14	1	43	89	15	6	34
	75	75	43	93	15	8	32

Based on % Starting Torque for 875 RPM NEMA Design B Motors		100% @ 875 RPM			125% @ 870 RPM			150% @ 850 RPM			175% @ 840 RPM			200% @ 820 RPM					
		Rated Motor HP	Starting HP	Max. Time In Sec	Starting HP	Flow Charge Lbs	Flow Charge Oz	Max. Time In Sec	Starting HP	Flow Charge Lbs	Flow Charge Oz	Max. Time In Sec	Starting HP	Flow Charge Lbs	Flow Charge Oz	Max. Time In Sec			
11D & 11DL	5	5	1000	6.2	5	6	904	7.3	6	3	816	8.4	6	13	728	9.4	7	6	648
	7.5	7.5	800	9.3	6	13	656	10.9	7	10	572	12.6	8	5	527	14.0	9	0	488
15D	10	10	560	12.4	9	8	498	14.6	10	9	440	16.8	11	7	383	18.7	12	5	334
	15	15	430	19	11	7	326	22	12	8	280	25	13	5	250	28	14	6	220
	20	20	300	25	12	13	250	29	13	14	210	34	15	1	178	38	15	8	156

Table 2: Thermal Capacity for FLEXIDYNE Drive

FLEXIDYNE Size	Starting HP	Maximum Allowable Acceleration Time in Seconds for Standard Motor Speeds at Various Starting Cycles																							
		2 Hours		1 Hour		30 Minutes		15 Minutes		10 Minutes		5 Minutes		2 Minutes		1 Minute									
		870	1160	1750	870	1160	1750	870	1160	1750	870	1160	1750	870	1160	1750	870	1160	1750	870	1160	1750	870	1160	1750
11	5	1000	950	450	290	130	46	21	
	10	600	480	560	280	180	80	30	40	13	20	
	20	320	308	116	300	308	116	150	175	96	90	130	80	42	65	50	15	26	21	6	13	11	
	30	136	80	136	80	80	67	60	56	30	35	12	14	6	7	
	40	107	44	107	44	63	37	47	32	23	20	9	8	4	4	
	50	78	34	78	34	46	28	35	24	17	15	6	6	3	3	
	60	24	24	20	17	10	4	
	70	21	21	17	14	9	3	
	80	18	18	15	12	8	
	90	16	16	13	11	7	
100	14	14	12	10	6		
15	10	560	560	350	260	160	85	53		
	20	300	230	300	230	170	190	130	160	80	100	42	44	25	23		
	30	200	167	200	167	125	140	95	117	60	73	32	32	19	17		
	40	145	105	145	105	90	90	68	74	42	46	22	20	14	10		
	50	81	35	81	35	68	30	57	28	35	19	15	12	7	8	
	60	56	31	56	31	47	27	40	25	25	16	11	10	5	7	
	70	47	27	47	27	40	23	34	21	21	14	9	9	5	6	
	80	39	33	39	23	33	20	28	17	17	12	7	7	4	5	
	90	33	20	33	20	28	16	24	15	14	10	6	6	3	4	
	100	28	16	28	16	24	13	20	13	12	9	5	5	3	3	
15	110	15	15	12	12	8	5		
	120	14	14	11	11	7	4		
	130	13	13	10	10	7	4		
	140	12	12	10	9	6	3		
	150	11	11	9	9	6	3		
	160	10	10	8	8	6		
	170	9	9	8	8	5		
	180	9	9	7	7	5		
	190	8	8	7	7	4		
	200	8	8	7	6	4		

REPLACEMENT OF PARTS

Disassembly

1. Loosen set screws in collar and remove FLEXIDYNE Drive from motor shaft.
2. Remove filler plug and drain flow charge from FLEXIDYNE.
3. Remove housing screws and remove housing cover. Remove cover seal retainer by inserting a small pin in the holes for the drive screws and tapping on rod to remove drive screws. Remove cover seal.
4. Remove the four drive hub screws and remove the drive housing. Remove housing seal.
5. Remove seal felt and seal shield from driven hub. Remove rotor.
6. Remove collar, outer ball bearing snap ring, and slide driven hub off drive hub.
7. Remove inner ball bearing snap ring and remove ball bearing.
8. To remove needle bearing from driven hub, place a plug in the right hand end (as viewed in the drawing) of the driven hub and press on plug to remove bearing and seal.
7. Using dowel pins as guides place drive housing in position and tap gently until housing starts to pass over housing seal. The seal may tend to cock. A wire or other blunt probe may be used to push outer corner of seal into position in drive housing. Rotating the driven hub may also help to position the seal properly. When seal is properly positioned tap drive housing into place. Install and tighten the four drive hub screws.
8. Install cover seal (gray in color) in drive housing cover. Line up holes in seal retainer with holes in cover and install drive screws.
9. Place cover in position on drive housing so that filler plugs are diametrically opposed. Install and tighten housing screws.
10. Install filler plug. Tighten to recommended torque of 200 inch-pounds for size 11D & 11DL; 700 inch-pounds for size 15D.

Reassembly

1. Press needle bearing into driven hub. Left hand end of needle bearing should be 5/16 from left hand end of driven hub for size 11D and 11DL; ¼ from left hand end of driven hub for size 15D. Bearing should be completely filled with high temperature roller bearing grease. Tap needle bearing seal into place, flush with end of driven hub.
2. Press ball bearing onto drive hub, pressing against inner (not outer) race of ball bearing. Install inner ball bearing snap ring.
3. Slide drive hub into driven hub. Press against bearing not drive hub. Be careful not to damage needle bearing seal with any sharp edge on the drive hub during assembly.
4. Install outer ball bearing snap ring, seal shield, seal felt and motor shaft collar.
5. Place rotor in position on driven hub. Install and tighten rotor screws.
6. Stand FLEXIDYNE on collar end and place housing seal (red in color) in position on end of driven hub.

Replacement Parts for 11D, 11DL and 15D FLEXIDYNE Drive

Note: The two digit numbers are for reference only. Order parts by the six digit numbers in the Parts List. Each six digit number is a complete identification of the part or assembly.

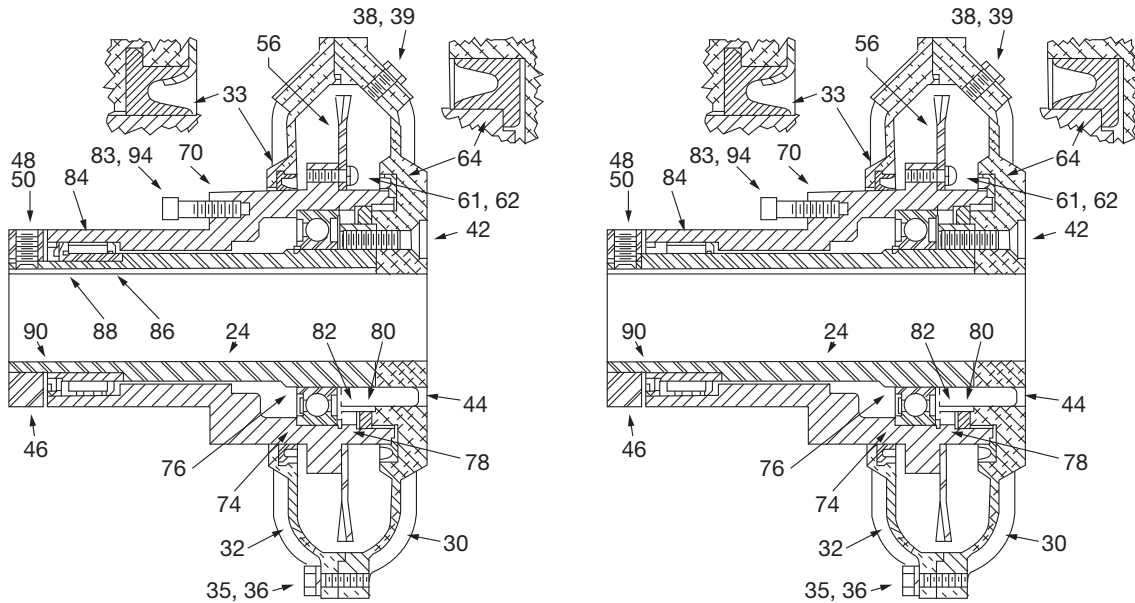

Reference	Name of Part	No. Req'd	Part Numbers			Reference	Name of Part	No. Req'd	Part Numbers				
			11D	11DL	15D				11D	11DL	15D		
①	Drive Hub And Housing Assembly	1-3/8" Bore	1	391297	50	Shaft Set Screw	1-3/8" Bore	1	400131
		1-5/8" Bore	1	391300			1-5/8" Bore	1	400130
		1-7/8" Bore	1	391386	391392			1-7/8" Bore	1	400130	400158
		2-1/8" Bore	1	391388	391396			2-1/8" Bore	1	400126	400158
		2-3/8" Bore	1	391400			2-3/8" Bore	1	400154
32	Housing Cover And Seal Assembly ② ③ Housing Cover	1	391464	391464	391494	56	Rotor	1	311006	311006	315006		
		1	311081	311081	315079	61	Rotor Screw	6	415108	415108	415112		
33	③ Cover Seal (Gray) with Drive Screws and Retainer	1	391255	391255	391256	62	Lockwasher	6	419009	419009	419010		
			64	Housing Seal (Red)	1	311038	311038	315017		
35	Housing Screw	6	411057	411057	411072	70	Driven Hub	1	311005	311005	315005		
36	Lockwasher	6	419010	419010	419011	74	Ball Bearing⑥	1	391219	391219	391227		
38	Filler Plug	2	308021	308021	315021	76	Inner Snap Ring	1	421019	421019	421027		
39	Lockwasher	2	419121	419121	419123	78	Outer Snap Ring	1	421032	421032	421039		
42	Drive Hub Screw ④	4	415070	415070	415078	80	Seal Felt	1	311024	311024	315024		
46	Drive Hub Collar	1	311020	311020	315020	82	Seal Shield	1	311027	311027	315027		
48	Key Set Screw	1-3/8" Bore	1	400130	84	Needle Bearing⑦	1	426024	426024	426028	
		1-5/8" Bore	1	400126	86	Needle Bearing Inner Race⑧	1	426036	426037	
		1-7/8" Bore	1	400126	400154	88	Needle Bearing Snap Ring	1	421018	421022	
		2-1/8" Bore	1	400122	400154	90	Needle Bearing Sea	1	434003	434004	434005	
		2-3/8" Bore	1	400154	93	Screw	⑤	417114	417114	417181	
						94	Lockwasher	⑤	419011	419011	419013		

① Includes part numbers 24, 30, 42 & 44. Parts 24 (Drive Hub) and 30 (Drive Housing) are fitted and must be ordered together.

② Includes parts listed immediately below.

③ Parts make up the assemblies under which they are listed.

④ Included in Drive Hub and Housing Assembly.

⑤ 4 req'd. on sizes 11D and 11DL; 6 req'd. on size 15D.

⑥ SKF Part No's. - 11D & 11DL: 60142RS/C3/RB; New Departure Part No's. - 11D & 11DL: Z993L14X1V; 15D-773L18XIV

⑦ Torrington Part No's. - 11D & 11DL: [??239]44120H; 15D: B-5612.

⑧ Torrington Part No's. - 11D & 11DL: IR4016; 15D: IR-485632.

FLEXIDYNE Trouble Analysis

Symptom	Cause	Cure
Vibration	1. Misalignment	1. Realign drive or coupling
	2. Bent shaft	2. Replace or straighten
	3. Excess flow charge	3. Remove small amount of flow charge
	4. Fused flow charge	4. Correct the overload. Replace flow charge
	5. Improper installation - Output shaft jammed against housing	5. Readjust spacing between shafts and FLEXIDYNE
Erratic Acceleration	1. Breakdown of flow charge	1. Replace flow charge
	2. Caked flow charge	2. Moist environment - use stainless flow charge
FLEXIDYNE Doesn't Slip	1. Improper installation - Output shaft jammed against housing	1. Readjust spacing between shafts and FLEXIDYNE
	2. Flow charge in bearings - causing bearing seizure	2. Replace seals, bearings and flow charge or replace FLEXIDYNE
Excessive Slippage	1. Not enough flow charge	1. Add flow charge
	2. Overload	2. Relieve overload
	3. Worn flow charge	3. Replace flow charge
	4. Worn rotor	4. Replace rotor
Poor or short flow charge life	1. Excessive slip at start-up	1. Add flow charge to reduce starting time
	2. Excessive inching or jogging of machine	2. Install time delay in motor control circuit

FLEXIDYNE Flow Charge Analysis

Condition	Cause
1. Red oxide color, granular consistency	1. Normal after some usage
2. Red oxide color powdery consistency, possibly with powdery flakes	2. Worn-out, can cause FLEXIDYNE damage
3. Black, powdery	3. Rotor worn, excessive slip and heat
4. Red oxide, powdery and chunky	4. Worn-out and moisture present
5. Clumping of flow charge	5. Moisture present, use stainless flow charge

Dodge Industrial, Inc.
1061 Holland Road
Simpsonville, SC 29681
+1 864 297 4800



* 4 0 3 2 - 0 3 2 2 *