

BALDOR

Instruction Manual For D-Series Clutch/Brake Modules

SAFETY NOTICE: **WARNING** statements describe conditions that may lead to personnel injury including potentially fatal injuries if the machine is improperly used and warnings are not followed. **Caution** statements describe conditions that may lead to equipment damage.

WARNING: Be sure to read and follow all Instruction, Warning and Caution statements in the appropriate motor manual. Failure to do so may result in serious or fatal injury.

WARNING: Only qualified personnel should attempt the installation, operation and maintenance of this equipment. Proper guards and other suitable safety devices or procedures as may be desirable or as may be specified in safety codes, are neither provided by Baldor nor are the responsibility of Baldor. Safety devices are the owners responsibility.

WARNING: Disconnect all electrical power from the motor and accessory devices and TAG Power Source before performing this procedure. Electrical shock can cause serious or fatal injury.

Receiving & Inspection

When you receive your control, there are several things you should do immediately.

1. Observe the condition of the shipping container and report any damage immediately to the commercial carrier that delivered your control.
2. Remove the control from the shipping container and remove all packing materials from the control. The container and packing materials may be retained for future shipment.
3. Verify that the part number of the control you received is the same as the part number listed on your purchase order.
4. Inspect the control for external physical damage that may have been sustained during shipment and report any damage immediately to the commercial carrier that delivered your control.

D-Series Clutch/Brake Modules Series DMCCB, DMCCO, DMCBO, DMCBX, DMSCB and DMSCO

Description The D-Series Modules are designed according to NEMA standards for mounting and may be used with standard power transmission equipment. All Brake Modules are factory assembled, adjusted and burnished for easy, accurate installation. This allows the unit to achieve its full rated torque out of the box. Table 1 shows the mounting dimensions.

All parts should be examined for any damage during the shipping and handling process. All parts must be clean and free of any foreign material before attempting installation.



DMCCB
C-Face
Clutch/Brake Module



DMCBO
C-Face
Brake Only Module



DMSCB
Base Mount
Clutch/Brake Module

DMCCO
C-Face
Clutch Only Module

DMCBX
C-Face
Brake Only Module
No Output Shaft (not shown)

DMSCO
Base Mount
Clutch Only Module

Table 1 Mounting Information

DMC	Motor Frame		Shaft Dia. (in)	C-Face Mounting Pilot Diameter (in)
	Module Size	Motor Frame T-Frame Size		
50	56C, 48Y	56C	0.625	4.5"
100	56C, 48Y	56C	0.625	4.5"
180	143TC, 145TC	182C/184C	0.875	4.5"
210	182TC, 184TC	213C/215C	1.125	8.5"
256	213TC/215TC	254C/256C	1.375	8.5"

WARNING: Disconnect all electrical power from the motor and accessory devices and TAG Power Source before performing this procedure. Electrical shock can cause serious or fatal injury.

Mounting, C-Face Mounting Module On C-Face Motor

- The motor shaft key has been installed in the module hub. Hub set screws have been aligned with the housing access holes. If hub has been rotated, re-align the set screw with the access holes by rotating the hub slowly.
(DMCBO and DMCBX only) Access to set screws is through the air vent slots.
 - Rotate the motor shaft to align keyway and mounting stud bolt pattern that will secure the module to the motor. Be sure to remove any burrs from the motor shaft O.D. before attempting to mount the module.
The motor should not be used if motor shaft end play exceeds .030".
 - Remove and discard the four nuts and/or washers used to hold the four module stud bolts in position during shipment. Slide the module onto the motor shaft.
Do not hammer module into place or use the mounting bolts to draw the module onto the motor, as it could damage the unit. If the unit binds on the motor shaft, check for burrs. Position the unit with the air vents down for drip proof requirements.
- Using the four (4) bolts provided, tighten the bolts into the motor housing. See Table 2 for recommended bolt torque. Do not overtighten as damage may result.

Table 2 Recommended Tightening Torque

DMC	C-Face Bolts		Shaft Setscrews		
	Unit Size	Size	Torque (lb-in)	Size	Torque (lb-in)
50		³ / ₈ -16	220	⁵ / ₁₆ -18	156
100		³ / ₈ -16	220	⁵ / ₁₆ -18	156
180		³ / ₈ -16	220	⁵ / ₁₆ -18	156
210		¹ / ₂ -13	480	⁵ / ₁₆ -18	156
256		¹ / ₂ -13	480	⁵ / ₁₆ -18	156

- Tighten both (2) hub set screws securely onto the motor shaft.
Proper tightening of set screws is imperative to the proper operation of the unit (See Table 2). Failure to do so will result in damage to the unit.
 - Remove armature spacer(s) (they have been inserted between the armature(s), through the air vent holes to prevent movement during shipment).
- Note: Check set screw torque after a short run time to ensure proper tightening.
- C-face modules that have been removed from the motor and reinstalled, must have their armature air gaps reset. See the Maintenance section "Resetting Armature Air Gaps".

Mounting, Reducer Mounting Module to a Reducer

1. The module should first be mounted to motor, then module/motor assembly mounted to the reducer. Ensure mating shaft diameters are the proper size.
2. Position module output shaft and key with corresponding hub in the C-face reducer.
3. Slide the assembly together until the pilot diameters on the mounting surfaces mate.
4. Fasten the module to the reducer flange with appropriate bolts. (See Chart 2 for Thread Size.) Thread length is dependent on thickness of reducer flange. A rigid connection is imperative to the proper operation of the assembly.
5. Applications with single phase motors or severe duty with large inertia's and loads, use engineering adhesive to reduce fretting of the module shaft.

Mounting Module to a Motor Mount Base

1. The motor mount base is easily fastened to a motor/module assembly. The holes in the motor mount base match those in the output (brake) end of the module.
2. Using the four (4) bolts supplied, securely fasten the module to the base with air vents facing down.
3. Attach sheaves, pulleys, or sprockets, etc., to the shaft extension according to the manufacturer's recommendations. See Overhung Load Data.

Base Mounted Modules (DMSCB and DMSCO)

1. The base mount bracket allows the clutch/brake or clutch only module to be used as a stand alone unit.
2. With the base attached to a rigid mounting frame, position the module on the base with the air vents facing down.
3. The C-face pilots on both module faces mate with the pilot diameters on the base.
4. Using the four (4) bolts supplied, securely fasten the module to the base. Attach sheaves, pulleys, or sprockets etc., to the shaft extensions according to the manufacturer's recommendations. See Overhung Load Data.

Overhung Load Data The maximum overhung load which can be applied to the output shaft of a brake module can be determined from Table 3.

Table 3 Overhung Loads

DMC Module Size	Max. Load Rating (lb) Distance from Housing (D)		
	1"	2"	3"
50	237	138	97
100	237	138	97
180	234	162	124
210	475	343	263
256	475	343	263

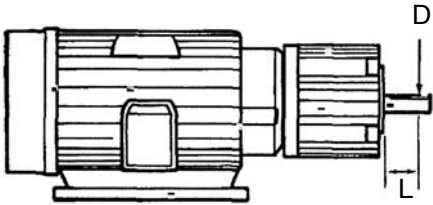

L= Total lateral load exerted on shaft due to pull on both sides of pulley, sprocket or other component due to tension plus the force due to the work when running.

Load ratings based on B₁₀ Life of 10,000 Hrs. at 1800 RPM.

WARNING: Disconnect all electrical power from the motor and accessory devices and TAG Power Source before performing this procedure. Electrical shock can cause serious or fatal injury.

Electrical Connection See Electrical Data in Tables 4, 5 and 6.

Each module has a standard threaded $\frac{1}{2}$ " conduit connection.

Wiring diagrams are provided with the power supplies.

Attach two (2) white leads (brake) to proper DC voltage supply.

Table 4 DMC/DMS 50 MODULE

Voltage (DC)	90VDC		24VDC		6VDC	
	Clutch	Brake	Clutch	Brake	Clutch	Brake
Resistance@20°C (ohms)	434	460	30	30	1.86	1.97
Current (amps)	0.207	0.196	0.80	0.80	3.23	3.05
Power (watts)	18.6	17.6	19.2	19.2	19.4	18.3
Coil Buildup (milliseconds)	50	35	48	34	46	32
Coil Decay (milliseconds)	15	6	15	6	15	6

Table 5 DMC/DMS 100/180 MODULE

Voltage (DC)	90VDC		24VDC		6VDC	
	Clutch	Brake	Clutch	Brake	Clutch	Brake
Resistance@20°C (ohms)	432	476	29.8	32.3	1.86	2.06
Current (amps)	0.208	0.189	0.81	0.74	3.23	2.91
Power (watts)	18.7	17.0	19.4	17.8	19.4	17.5
Coil Buildup (milliseconds)	106	96	104	95	100	91
Coil Decay (milliseconds)	13	16	14	17	13	16

Table 6 DMC/DMS 210/256 MODULE

Voltage (DC)	90VDC		24VDC		6VDC	
	Clutch	Brake	Clutch	Brake	Clutch	Brake
Resistance@20°C (ohms)	231	250	14.9	16.2	0.90	0.91
Current (amps)	0.390	0.360	1.61	1.48	6.67	6.59
Power (watts)	35.1	32.4	38.6	35.5	40	39.5
Coil Buildup (milliseconds)	130	115	128	112	120	110
Coil Decay (milliseconds)	20	18	19	17	20	17

Note: Coil build-up to 80% of Rated Current. Coil Decay Time with DODGE Power Supply. Due to variations in other manufacturers' supplies, the decay time may vary.

WARNING: Disconnect all electrical power from the motor and accessory devices and TAG Power Source before performing this procedure. Electrical shock can cause serious or fatal injury.

Maintenance Figure 1 shows the reference locations for items described in this procedure.

Figure 1 Reference Locations

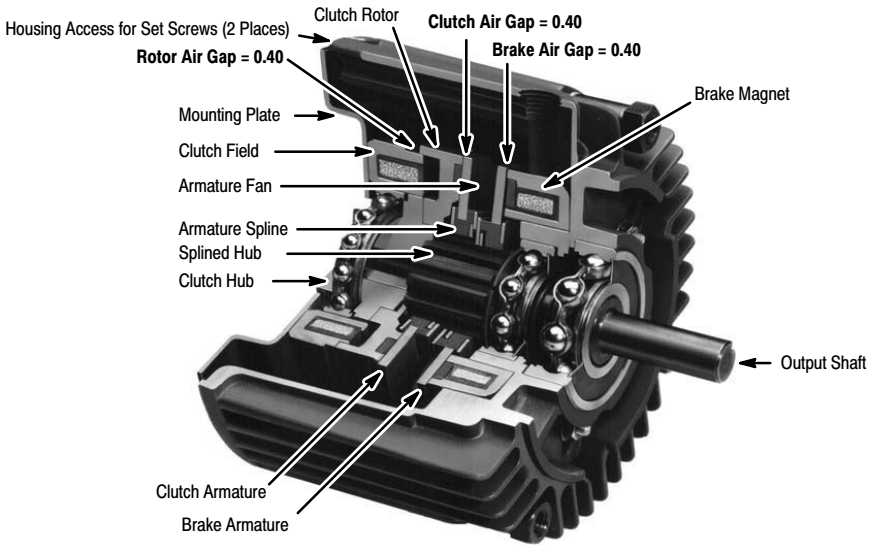

1. **Removal of Mounting Plate/Clutch Field and Clutch Rotor/Hub Assembly.**

The module mounting plate assembly is held in place by an RTV compound. It is easily removed by prying with a screwdriver. Use care not to bend or distort the plate when prying. Ensure that the cardboard lead wire retainer is in position before reassembling the module. Remove the worn armature(s) by rotating and gradually prying the armature off the splined hub. You must overcome the gripping force of the grip ring, a small puller simplifies this task. You must overcome this same gripping force when installing the new armature(s).

2. **Armature Replacement.**

Use care to avoid bending the armature washers during assembly. A soft mallet and/or block of wood can be used to start the armature onto the spline. With the finned armature surface facing away from the friction surface, push the brake armature flush against the brake magnet friction surface and release. The DYNA-GAP feature will automatically set the air gap.

When installing the clutch armature, orient the armatures with finned surfaces facing one another and align the armature screws of the brake armature with the scallops in the outside washer of the clutch armature. Incorrect orientation will not allow for proper air gaps. Push the clutch armature against the brake armature and release. See "Resetting Armature Air Gaps" procedure for setting the clutch armature air gap.

3. **Clutch Rotor Replacement.**

Remove worn rotor by removing the socket head cap screws and sliding the rotor off the clutch hub. Before installing the new rotor, clean all surfaces. Apply thread sealant to the socket head cap screws, torque each screw to the specified in Table 7.

Table 7

Module Size	Cap Screw Size	Torque (in.-lbs.)
50	#10-32	50-60
100	1/4-20	80-100
180	1/4-20	80-100
210	5/16-18	160-180
256	5/16-18	160-180

4. **Resetting Armature Air Gaps.**

If a module has been reinstalled or reassembled, the armature air gaps must be reset.

Reinstallation:

If the mounting plate assembly has not been removed from the module, insert the armature spacers through the housing vent slots just as it had been shipped. Make sure the armature(s) are held solidly against their adjacent friction surfaces. Mount the module according to the installation instructions. If the armature spacers have been misplaced or the mounting plate has been removed, follow the instructions for Reassembly.

Reassembly:

If the clutch and mounting plate assembly has been removed, push the clutch armature down the splined hub so that the brake armature is pushed flush against the brake magnet (this will set the brake armature air gap). Replace the clutch/hub/rotor and clutch field/mounting plate. Mount the module onto the motor shaft (see Mounting at the beginning of this manual).

Energize the clutch coil, insert two screwdrivers, 180 degrees apart, through the housing vent slots, and carefully pull the armature toward the rotor until the armature is flush against the friction surface. De-energize the clutch coil. The DYNA-GAP mechanism will automatically set the proper air gap.

5. **Bearing or Shaft Replacement** (not recommended)

Replacement of module shafts or bearings is not recommended. Installation requires special tools to avoid bearing damage during assembly. The bearings may also be damaged when attempting to remove the shaft from the housing. Complete unit replacement is recommended.

6. **Replacing Mounting Plate/Clutch Field/Clutch Rotor/Hub.**

This should be replaced as a single unit. The mounting plate and clutch field are welded together. The clutch rotor/hub assembly are then positioned with a bearing. The rotor may be removed and replaced if needed (see Step 3).

7. **Replacing the Brake Magnet.**

Remove the nuts fastening the old brake magnet to the housing and press the assembly out of the housing. Press the new magnet into position ensuring the assembly is bottomed into the housing cavity. Secure to housing using the nuts supplied.

Troubleshooting See Table 8

WARNING: Disconnect all electrical power from the motor and accessory devices and TAG Power Source before performing this procedure. Electrical shock can cause serious or fatal injury.

Table 8 Troubleshooting Guide

Symptom	Cause	Possible Solution
Armature rubbing – periodic noise to constant rubbing.	Clutch or Brake armature may be cocked, resulting in varying air gap and rubbing on adjacent friction surface when disengaged.	The clutch or brake armature may be cocked, resulting in varying air gap and rubbing on adjacent friction surface when disengaged.
Excessive clutch/brake overlap. Unit won't cycle repeatedly.	Switch or counting device may have inherent time delay constant.	Customer switch should be on the DC side of the rectifier (power supply). A counter or timer mechanism may include time constant circuit or diode which may create overlap. Check components.
Rapid wear or short life.	Module may be cycling too rapidly and/or operating at high temperatures (component selection may need review). The unit may be operating in a harsh environment. Actuation times may need adjustment.	Rapid Cycling: Fast, repetitive cycling will result in more rapid wear and higher temperatures. High temperatures will also accelerate wear rates. Ensure the unit is being ventilated as efficiently as possible to maximize life. Exposure to harsh environments such as on machinery that produces abrasive dust or grit may shorten the life of the unit. In these types of environments, an effort should be made to shield the module from abrasive materials. Minor adjustments to the actuation time can prevent premature failure of the unit. For a brake, the control potentiometer can be adjusted to a reduced setting to extend the actuation time, to increase the operating life.
Loss of torque.	Improper Air Gap Improper input voltage can cause complete loss of torque. Module may be nearing the end of its normal life or friction surface may be contaminated with grease or oil.	See "Resetting Armature Air Gaps" procedure for setting the clutch armature air gap. If a complete loss of torque occurs, check the brake input voltage as follows: Connect a DC voltmeter across the brake magnet field terminals. With the power to the coil and the potentiometer turned to the highest setting, the voltage should read within 10% of the unit's rating. As the potentiometer knob is adjusted counterclockwise, the voltage should decrease. If proper voltages are present, the mechanical components should be checked to ensure the brake has not been damaged or improperly installed. A slight loss in torque may become evident as a brake nears the end of its normal life. Grease or oil contamination can result in a substantial loss of torque. If the module is positioned near any machinery which requires frequent lubrication, care must be taken to avoid grease or oil contacting the friction surfaces. Should oil or grease reach the friction area, replace the brake.

Baldor District Offices

UNITED STATES

ARIZONA
PHOENIX
4211 S 43RD PLACE
PHOENIX, AZ 85040
PHONE: 602-470-0407
FAX: 602-470-0464

ARKANSAS
CLARKSVILLE
1001 COLLEGE AVENUE
CLARKSVILLE, AR 72830
PHONE: 479-754-9108
FAX: 479-754-9205

CALIFORNIA
LOS ANGELES
6480 FLOTTILLA STREET
COMMERCE, CA 90040
PHONE: 323-724-6771
FAX: 323-721-5859

HAYWARD
21056 FORBES AVENUE
HAYWARD, CA 94545
PHONE: 510-785-9900
FAX: 510-785-9910

COLORADO
DENVER
3855 FOREST STREET
DENVER, CO 80207
PHONE: 303-623-0127
FAX: 303-595-3772

CONNECTICUT
WALLINGFORD
65 SOUTH TURNPIKE ROAD
WALLINGFORD, CT 06492
PHONE: 203-269-1354
FAX: 203-269-5485

FLORIDA
TAMPA/PUERTO RICO/
VIRGIN ISLANDS
3906 EAST 11TH AVENUE
TAMPA, FL 33605
PHONE: 813-248-5078
FAX: 813-247-2984

GEORGIA
ATLANTA
62 TECHNOLOGY DRIVE
ALPHARETTA, GA 30005
PHONE: 770-772-7000
FAX: 770-772-7200

ILLINOIS
CHICAGO
340 REMINGTON BLVD.
BOLINGBROOK, IL 60440
PHONE: 630-296-1400
FAX: 630-226-9420

INDIANA
INDIANAPOLIS
5525 W. MINNESOTA STREET
INDIANAPOLIS, IN 46241
PHONE: 317-246-5100
FAX: 317-246-5110

IOWA
DES MOINES
1800 DIXON STREET, SUITE C
DES MOINES, IA 50316
PHONE: 515-263-6929
FAX: 515-263-6515

MARYLAND
BALTIMORE
6660 SANTA BARBARA RD.
SUITES 22-24
ELKDRIDGE, MD 21075
PHONE: 410-579-2135
FAX: 410-579-2677

MASSACHUSETTS
BOSTON
6 PULLMAN STREET
WORCESTER, MA 01606
PHONE: 508-854-0708
FAX: 508-854-0291

MICHIGAN
DETROIT
5903 PROGRESS DRIVE
STERLING HEIGHTS, MI 48312
PHONE: 586-978-9800
FAX: 586-978-9969

MINNESOTA
MINNEAPOLIS
21080 134TH AVENUE NORTH
ROGERS, MN 55374
PHONE: 763-428-3633
FAX: 763-428-4551

MISSOURI
ST LOUIS
422 INDUSTRIAL DRIVE
MARYLAND HEIGHTS, MO 63043
PHONE: 314-298-1800
FAX: 314-298-7660

KANSAS CITY
1501 BEDFORD AVENUE
NORTH KANSAS CITY, MO 64116
PHONE: 816-587-0272
FAX: 816-587-3735

NEW YORK
AUBURN
ONE ELLIS DRIVE
AUBURN, NY 13021
PHONE: 315-255-3403
FAX: 315-253-9923

NORTH CAROLINA
GREENSBORO
1220 ROTHERWOOD ROAD
GREENSBORO, NC 27406
PHONE: 336-272-6104
FAX: 336-273-6628

OHIO
CINCINNATI
2929 CRESCENTVILLE ROAD
WEST CHESTER, OH 45069
PHONE: 513-771-2600
FAX: 513-772-2219

CLEVELAND
8929 FREEWAY DRIVE
MACEDONIA, OH 44056
PHONE: 330-468-4777
FAX: 330-468-4778

OKLAHOMA
TULSA
7170 S. BRADEN, SUITE 140
TULSA, OK 74136
PHONE: 918-366-9320
FAX: 918-366-9338

OREGON
PORTLAND
20393 SW AVERY COURT
TUALATIN, OR 97062
PHONE: 503-681-9010
FAX: 503-681-9012

PENNSYLVANIA
PHILADELPHIA
1033 THOMAS BUSCH
MEMORIAL HIGHWAY
PENNNSAUKEN, NJ 08110
PHONE: 856-661-1442
FAX: 856-663-6363

PITTSBURGH
159 PROMINENCE DRIVE
NEW KENSINGTON, PA 15068
PHONE: 724-889-0092
FAX: 724-889-0094

TENNESSEE
MEMPHIS
4000 WINCHESTER ROAD
MEMPHIS, TN 38118
PHONE: 901-365-2020
FAX: 901-365-3914

TEXAS
DALLAS
2920 114TH STREET SUITE 100
GRAND PRAIRIE, TX 75050
PHONE: 214-634-7271
FAX: 214-634-8874

HOUSTON
10355 W. LITTLE YORK ROAD
SUITE 300
HOUSTON, TX 77041
PHONE: 281-977-8500
FAX: 281-977-8510

UTAH
SALT LAKE CITY
2230 SOUTH MAIN STREET
SALT LAKE CITY, UT 84115
PHONE: 801-832-0127
FAX: 801-832-8911

WISCONSIN
MILWAUKEE
1960 SOUTH CALHOUN ROAD
NEW BERLIN, WI 53151
PHONE: 262-784-5940
FAX: 262-784-1215

INTERNATIONAL SALES
FORT SMITH, AR
P.O. BOX 2400
FORT SMITH, AR 72902
PHONE: 479-646-4711
FAX: 479-648-5895

CANADA
EDMONTON, ALBERTA
4053-92 STREET
EDMONTON, ALBERTA T6E 6R8
PHONE: 780-434-4900
FAX: 780-438-2600

TORONTO
OAKVILLE, ONTARIO
2750 COVENTRY ROAD
OAKVILLE, ONTARIO L6H 6R1
PHONE: 905-829-3301
FAX: 905-829-3302

MONTREAL, QUEBEC
5155 J-ARMAND BOMBARDIER
SAINT-HUBERT, QUEBEC
CANADA, J3Z 1G4
PHONE: 514-933-2711
FAX: 514-933-8639

VANCOUVER,
BRITISH COLUMBIA
1538 KEBET WAY
PORT COQUITLAM,
BRITISH COLUMBIA V3C 5M5
PHONE: 604-421-2822
FAX: 604-421-3113

WINNIPEG, MANITOBA
ROWVILLE, VICTORIA, 3178 AUSTRALIA
PHONE: (61) (2) 9674 5455
PHONE: 204-942-5205
FAX: 204-956-4251

AUSTRALIA
UNIT 3, 6 STANTON ROAD
SEVEN HILLS, NSW 2147, AUSTRALIA
PHONE: (61) (2) 9674 5455
FAX: (61) (2) 9674 2495

UNIT 8, 5 KELLETTS ROAD
ROWVILLE, VICTORIA, 3178 AUSTRALIA
PHONE: (61) (3) 9753 4355
FAX: (61) (3) 9753 4366

EL SALVADOR
RESIDENCIAL PINARES DE SUIZA
POL. 15 #44,
NVA. SAN SALVADOR, EL SALVADOR
PHONE: +503 2288-1519
FAX: +503 2288-1518

CHILE
LUIS THAYER OJEDA 166,
OF 402 - PROVIDENCIA
SANTIAGO, CHILE
PHONE: +56 2 816 9900

CHINA
160 SONG SHENG ROAD
SONGJIANG INDUSTRY ZONE
SHANGHAI 201613, CHINA
PHONE: +86 21 5760 5335
FAX: +86 21 5760 5336

GERMANY
HERMANN-HEINRICH - GOSSEN 3
50858 KÖLN, GERMANY
PHONE: 49-2234379410
FAX: 49-22343794164

DIESELSTRASSE 22
D-85555 KIRCHHEIM
MÜNCHEN, GERMANY
PHONE: +49 89 90 5080
FAX: +49 89 90 50 8492

INDIA
14, COMMERCE AVENUE
MAHAGANESH COLONY
PAUD ROAD
PUNE - 411038
MAHARASHTRA, INDIA
PHONE: +91 20 25 45 27 17 / 18
FAX: +91 20 25 45 27 19

INDONESIA
TALAVERA OFFICE PARK,
28TH FLOOR, SUITE M18
Jl. T.B. SIMATUPANG, KAV. 22-26
JAKARTA 12430, INDONESIA
PHONE: +62 21 7599 9879
FAX: +62 21 7599 9878

ITALY
VIA SOTTOBOSCO 30
BALERNA CH-6828
PHONE: +41 91 683 6161
FAX: +41 91 630 2633

JAPAN
DIA BLDG 802,
2-21-1 TSURUYA-CHO,
KANAGAWA-KU
YOKOHAMA, 221-0835, JAPAN
PHONE: 81-45-412-4506
FAX: 81-45-412-4507

MEXICO
LEON, GUANAJUATO
KM. 2.0 BLVD. AEROPUERTO
LEON 37545, GUANAJUATO, MEXICO
PHONE: +52 477 761 2030
FAX: +52 477 761 2010

MIDDLE EAST & NORTH AFRICA
VSE INTERNATIONAL CORP.
P. O. BOX 516
BUFFALO GROVE, IL 60089-5618
PHONE: 847 590 5547
FAX: 847 590 5587

PANAMA
AVE. RICARDO J. ALFARO
EDIFICIO SUN TOWERS MALL
PISO 2, LOCAL 55
CIUDAD DE PANAMA, PANAMA
PHONE: +507 236-5155
FAX: +507 236-0591

SINGAPORE
18 KAKI BOUKIT ROAD 3, #03-09
ENTREPRENEUR BUSINESS CENTRE
SINGAPORE 415978
PHONE: (65) 6744 2572
FAX: (65) 6747 1708

SWITZERLAND
POSTFACH 73
SCHUTZENSTRASSE 59
CH-8245 FEUERHALEN
SWITZERLAND
PHONE: +41 52 647 4700
FAX: +41 52 659 2394

TAIWAN
1F, NO 126 WENSHAN 3RD STREET,
NANTUN DISTRICT,
TAICHUNG CITY 408
TAIWAN R.O.C
PHONE: (886) 4 238 04235
FAX: (886) 4 238 04463

UNITED KINGDOM
6 BRISTOL DISTRIBUTION PARK
HAWKLEY DRIVE
BRISTOL BS32 0BF U.K.
PHONE: +44 1454 850000
FAX: +44 1454 859001

VENEZUELA
AV. ROMA, OTA EL MILAGRO, URB.
CALIFORNIA NORTE
CARACAS, 1070
VENEZUELA
PHONE/FAX: +58 212 272 7343
MOBILE: +58 414 114 8623

BALDOR

World Headquarters

P.O. Box 2400 Fort Smith, AR 72902-2400
(479) 646-4711 Fax (479) 648-5792

