

Instruction Manual

DODGE IEC Series Electric Clutches

These instructions must be read thoroughly before installation or operation.

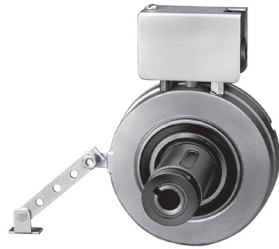

Figure 1

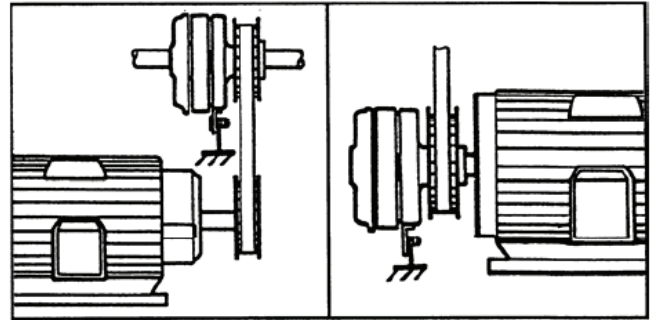

Figure 2

Figure 3

PRE-INSTALLATION INSTRUCTIONS

IEC Electric Clutches are preburnished at the factory and should not require any air gap adjustments prior to operation. IEC clutches are designed with DYNA-GAP™, a self-adjusting feature that will automatically compensate for friction surface wear. Armature air gaps should range from .030 to .050 inches, which have been pre-set at the factory.

INSTALLATION

WARNING: To ensure that drive is not unexpectedly started, turn off and lock out or tag power source before proceeding. Failure to observe these precautions could result in bodily injury.

1. All parts should be examined for any damage during the shipping and handling process. Measurements should be taken to ensure parts meet application requirements. All parts must be clean and free of foreign material before attempting assembly.
2. Mount drive component onto clutch. Mount properly sized sheave, pulley or sprocket onto clutch outer sleeve. These user supplied components should be mounted using DODGE® TAPER-LOCK® or Q.D. bushings. A key is provided. Setscrews used with straight bore components may damage the clutch bearings.
3. Mount clutch/drive component on shaft.

NOTE: Optimum mounting for the IEC Clutch is on a thru shaft where full support is achieved (Figure 2). However, there will be cases where shaft will not extend through unit (Figure 3). In these cases, it is recommended unit have a shaft at least 2/3 or more of length of assembly for support. When this situation exists, collar end of clutch should be toward support bearings.

WARNING: Because of the possible danger to person(s) or property from accidents which may result from the improper use of products, it is important that correct procedures be followed. Products must be used in accordance with the engineering information specified in the catalog. Proper installation, maintenance and operation procedures must be observed. The instructions in the instruction manuals must be followed. Inspections should be made as necessary to assure safe operation under prevailing conditions. Proper guards and other suitable safety devices or procedures, as may be desirable, or as may be specified in safety codes should be provided, and are neither provided by Baldor Electric Company, nor are the responsibility of Baldor Electric Company. This unit and its associated equipment must be installed, adjusted and maintained by qualified personnel who are familiar with the construction and operation of all equipment in the system and the potential hazards involved. When risks to persons or property may be involved, a holding device must be an integral part of the driven equipment beyond the speed reducer output shaft.

- A. Insert key into shaft. Keys should fit keyseat with a tight fit on sides and slight clearance over key.
- B. Slide preassembled IEC Clutch with mounted drive component onto shaft and into proper position. Ensure drive component aligns with driven component. Tighten setscrews in mounting collar to recommended tightening torques in Table 1. (Self-locking setscrews are recommended.)

Table 1 - Setscrew Tightening Torque

Setscrew Size	Key Hex Across Flats	Recommended Tightening Torque (in-lbs)
10-24	3/32	33
1/4-20	1/8	80
5/16-18	5/32	156
3/8-16	3/16	275

- C. Install user supplied belt or chain on sheave, pulley or sprocket.
- D. Secure field anti-rotation arm to tab on field and rotor assembly. Secure other end of anti-rotation arm to solid base as shown in Figure 4.

NOTE: Do not bolt down anti-rotation tab directly on machine member or bulkhead as this could cause preloading of field bearings.

ELECTRICAL CONNECTIONS

DANGER: The user is responsible for conforming with the National Electrical Code and all other applicable local codes. Wiring practices, grounding, disconnects and overcurrent protection are of particular importance. Failure to observe these precautions could result in severe bodily injury or loss of life.

4. DODGE IEC Series Clutches operate on standard DC voltage coils. To operate clutch with alternating current, an AC to DC power supply is required. Do not connect AC voltage directly to coil leads. Wire two leads to power supply. DODGE Power Supplies are available with a wiring diagram showing proper electrical connections.



MAINTENANCE GUIDE

WARNING: To ensure that drive is not unexpectedly started, turn off and lock out or tag power source before proceeding. Failure to observe these precautions could result in bodily injury.

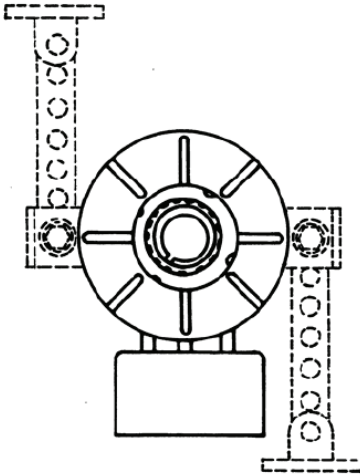

Figure 4

Table 2 - Electrical Coil Data

IEC-375			
Voltage—DC	90	24	6
Resistance @ 20°C—Ohms	434	30.1	1.86
Current—Amperes	.20	.789	3.23
Watts	18.7	18.9	19.4
Coil Build-up—milliseconds	50	48	46
Coil Decay—milliseconds	15	15	15
IEC-475			
Voltage—DC	90	24	6
Resistance @ 20°C—Ohms	432	29.8	1.86
Current—Amperes	.20	.805	3.22
Watts	18.7	19.3	19.3
Coil Build-up—milliseconds	106	104	100
Coil Decay—milliseconds	13	14	13
IEC-650			
Voltage—DC	90	24	6
Resistance @ 20°C—Ohms	230	14.9	.90
Current—Amperes	.39	1.61	6.63
Watts	35	39	39
Coil Build-up—milliseconds	130	128	120
Coil Decay—milliseconds	20	19	20
IEC-825			
Voltage—DC	90	24	6
Resistance @ 20°C—Ohms	220	14.5	1.10
Current—Amperes	.41	1.65	5.4
Watts	37	40	32
Coil Build-up—milliseconds	230	215	190
Coil Decay—milliseconds	120	125	115

NOTE: Coil build-up is to 80% of Rated Current. Coil Decay Time is with DODGE Power Supply. Due to variations in other manufacturers' supplies, the delay time may vary.

TASK

PROCEDURE

Armature Replacement

Remove worn armature by rotating and gradually prying armature off splined hub. (On sizes 650 and 825 this will involve first removing retaining ring on outside diameter of spline hub.) You must overcome gripping force of grip ring, therefore, use of a small puller simplifies this task. You must overcome this same gripping force when installing new armature. Care must be taken not to bend armature washers during assembly. A soft mallet and/or block of wood can be used to start armature onto spline. With finned armature surface facing away from friction surface, push clutch armature flush against clutch magnet friction surface and release. The DYNAGAP™ feature will automatically set air gap. Reinstall retaining ring when finished.

Replacing the Clutch Field

Clutch field replacement is generally not required. For more information contact Baldor Electric Company, Dodge Engineering, Greenville, SC at 864-284-5700.

TROUBLESHOOTING GUIDE

DANGER: Subsequent steps require rotating parts and/or electrical circuits to be exposed. Stay clear if unit must be running or disconnect and lockout or tag power source if contact must be made. Failure to observe these precautions could result in severe bodily injury or loss of life.

SYMPTOM/CAUSE

SOLUTION

Armature rubbing, periodic noise to constant rubbing.

Disconnect power to motor. Adjust armature position using a screwdriver to pry the armature away (.060" to .090") from friction surface on which it is rubbing. Energize coil. Using even pressure, push armature toward friction surface until it is fully engaged. It should pull in by itself when it gets close enough. Remove pressure and de-energize coil. The DYNA-GAP™ self-adjusting feature will automatically maintain proper air gap (.030" to .050").

No engagement when coil is energized.

- (1) Coil may be shorted to ground.
- (2) Armature air gap is too large.

(1) Check coil resistance as follows: Disconnect power to motor. Connect ohmmeter to two clutch leads. Check value with Table 2 Electrical Coil Data. If OK, proceed to solution for checking armature air gap. If not OK, indicates some electrical problem with coil. Proceed to procedure for replacing clutch field in the Maintenance Guide. (2) Disconnect power to motor. Energize coil. Using even pressure, push armature toward friction material surface until armature engages fully. If armature still does not engage properly, see Armature rubbing.

Excessive overlap. Unit will not cycle repeatedly.

Customer switch should be on DC side of rectifier (power supply). A counter or timer mechanism may include a time constant circuit or diode which may create overlap. Check components.

Rapid wear or short life. Clutch may be cycling too rapidly and/or operating at high temperatures (component selection may need review). The unit may be operating in a harsh environment. Actuation times may need adjustment.

(1) Rapid Cycling: Fast, repetitive cycling will result in more rapid wear and higher temperatures. High temperatures will also accelerate wear rates. Ensure unit is being ventilated for maximum cooling to maximize life.
 (2) Exposure to harsh environments such as on machinery that produces abrasive dust or grit may shorten life of unit. In these types of environments, an effort should be made to shield clutch from abrasive materials.
 (3) Minor adjustments to actuation time can prevent premature failure of clutch. The control potentiometer, if provided, can be adjusted to a lower setting to extend actuation time, which can result in a longer operating life.

CAUTION: Only personnel familiar with wear patterns and the possible effect on the operation of the product's performance should adjust the potentiometer setting.

NOTE: Normal wear conditions will result in grooves appearing on the friction surfaces. Machining away these grooves can result in premature failure of the unit.

Loss of torque. Improper input voltage can cause complete loss of torque. The clutch may be nearing the end of its normal life or friction surface may be contaminated with grease/oil.

If a complete loss of torque occurs, initially check input voltage to clutch field as follows: Connect a DC voltmeter with proper range across clutch field's terminals. With power to coil and potentiometer turned to highest setting, voltage should read within 10% of unit's rating. As potentiometer knob is adjusted counterclockwise (lower), voltage should drop. If these checks prove proper voltages are being provided, then mechanical components of unit should be checked to ensure unit has not been damaged or improperly installed. A slight loss in torque may become evident as clutch nears the end of its normal life. Grease or oil contamination can result in a substantial loss of torque. If clutch is positioned near any machinery which requires frequent lubrication, care must be taken to avoid grease or oil contacting friction surfaces. Should oil or grease reach friction area, immediately clean friction surfaces and general area with a cloth dampened with a degreaser. Do not drench or soak friction material. Continued loss of torque will result if friction material is completely contaminated with oil or grease. Heat developed at friction surface will cause oil to bleed to surface, resulting in torque loss. In this case, friction surfaces need replacing.

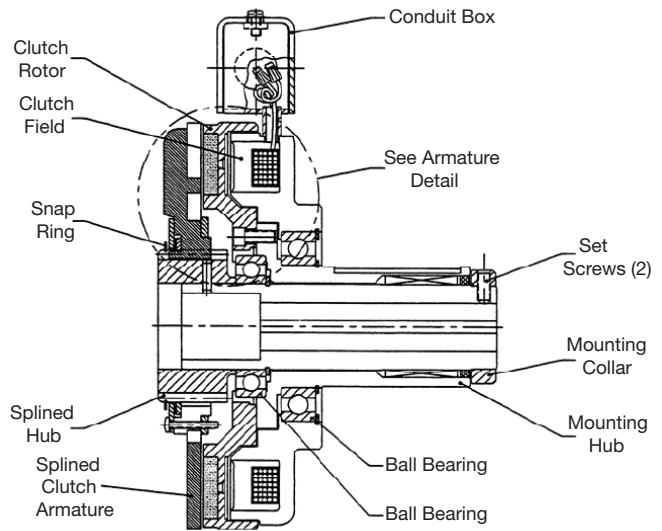

Figure 5 - IEC Cross Section

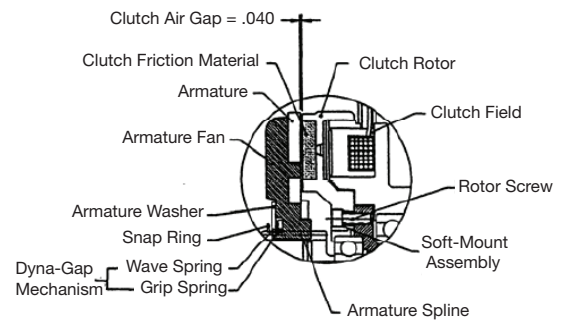

Figure 6 - Armature Detail

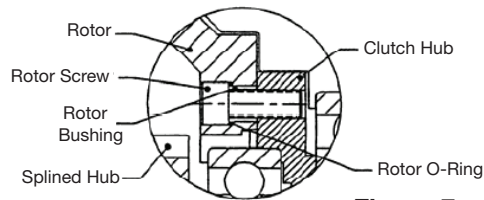

Figure 7 - Soft Mount Detail

BURNISHING PROCEDURE

For consistent engagement and full rated torque it is necessary to burnish the clutch.

Burnishing is a wearing-in or mating process to ensure the highest possible output torques will be obtained from the clutch.

NOTE: Burnishing is an important maintenance step. Running the unit without an initial burnishing break-in period may cause the equipment to operate erratically. Full rated torque will not be developed until friction surfaces develop full contact.

1. If possible, burnish units in their final application or location to ensure alignment of the mated parts.
2. If units cannot be burnished in their final application, mount units in a test stand observing concentricity, alignment and air gaps.

NOTE: If burnishing capability is not practical, cycle the clutch (several hundred engagements may be necessary) to wear unit in and allow torque to increase.

3. Using a filtered DC power supply, energize unit at 100% of rated coil voltage for 5 seconds maximum (this assures proper armature engagement against rotor), then reduce voltage to 30-40% of rated coil voltage.

4. Rotate the clutch armature at suggested RPM (Table 3) while holding the clutch field stationary to obtain a forced slip while the unit is energized.

Table 3 - Recommended Burnishing RPM

Unit Size	Burnishing RPM +10%
IEC-375	40
IEC-475	30
IEC-650	20
IEC-825	20

5. De-energize the unit after a 2-minute forced slip.

WARNING: To ensure that drive is not unexpectedly started, turn off and lock out or tag power source before proceeding. Failure to observe these precautions could result in bodily injury.

6. Measure static (or break away) torque of the unit with both friction members of the brake stationary, at rated voltage.
7. Static torque should be at the catalog rating (Table 4). If unit does not measure catalog rating, repeat step 4 after a cool down period of 5 minutes, until the unit comes up to the rated torque.

Table 4 - Standard Static Torques

Unit Size	Static Torque Ft-Lbs.
IEC-375	22
IEC-475	34
IEC-650	100
IEC-825	175

NOTES:

If clutch is required to decelerate a large inertia load, the normal slip that will occur when the load is engaged is frequently sufficient to cause the unit to become burnished. DODGE clutches typically will produce 50-90% of their rated torque "out-of-box" without burnishing. Customer should determine if "out-of-box" torques are adequate for application as torque will automatically improve with normal cycling (especially on high speed, high inertia load applications).

Do not prolong burnish beyond 2-minutes. Long burnish time will cause excessive heat build-up at friction faces resulting in poor performance.

Care must be taken to prevent contamination of the friction faces with oil or dirt particles during the burnishing process.



World Headquarters

P.O. Box 2400, Fort Smith, AR 72902-2400 U.S.A., Ph: (1) 479.646.4711, Fax (1) 479.648.5792, International Fax (1) 479.648.5895

Dodge Product Support

6040 Ponders Court, Greenville, SC 29615-4617 U.S.A., Ph: (1) 864.297.4800, Fax: (1) 864.281.2433

www.baldor.com

