

DODGE® POLY-DISC® Couplings with TAPER-LOCK® Bushings

These instructions must be read thoroughly before installation or operation. This instruction manual was accurate at the time of printing. Please see www.dodge-pt.com for updated instruction manuals.

WARNING: To insure that drive is not unexpectedly started, turn off and lock out or tag power source before proceeding. Failure to observe these precautions could result in bodily injury.

WARNING: All products over 25 kg (55 lbs) are noted on the shipping package. Proper lifting practices are required for these products.

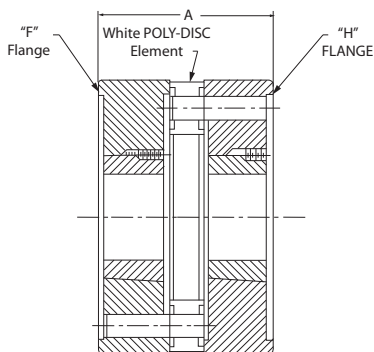

SIZES: 2-5/8 & 3-1/4

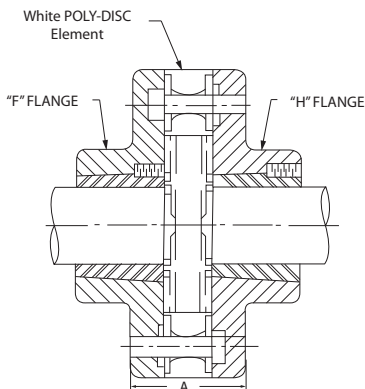

SIZES: 4 Thru 10

INSTALLATION:

1. Install TAPER-LOCK flanges on shafts per the instruction manual (MN4044) packed with TAPER-LOCK bushings or find the instruction manuals online at www.dodge-pt.com. Mount flanges on shafts with bushing ends flush with shaft ends.
2. Install coupling disc. Assemble disc to flanges with pins in alternate holes of the POLY-DISC coupling

assembly. Position shafts so that both flanges just touch the small spacer buttons on the disc. No further measurement is required. If shaft end float is to occur, locate shafts in the mid-position of the end float when establishing flange spacing.

NOTE: The POLY-DISC element will have a slight interference fit when installed over the flange pins. This feature will reduce pin wear and extend coupling life.

WARNING: Because of the possible danger to persons(s) or property from accidents which may result from the improper use of products, it is important that correct procedures be followed: Products must be used in accordance with the engineering information specified in the catalog. Proper installation, maintenance and operation procedures must be observed. The instructions in the instruction manuals must be followed. Inspections should be made as necessary to assure safe operation under prevailing conditions. Proper guards and other suitable safety devices or procedures as may be desirable or as may be specified in safety codes should be provided, and are neither provided by Baldor Electric Company nor are the responsibility of Baldor Electric Company. This unit and its associated equipment must be installed, adjusted and maintained by qualified personnel who are familiar with the construction and operation of all equipment in the system and the potential hazards involved. When risk to persons or property may be involved, a holding device must be an integral part of the driven equipment beyond the speed reducer output shaft.

BALDOR • DODGE®

3. Check spacing and angular alignment by measuring dimension "A" at four places 90° apart around the O.D. of the coupling. Flanges must be aligned so that all four measured dimensions do not vary more than "B" in Table 1. Excessive angular misalignment would be indicated if the four measured dimensions vary more than "B."
4. Check parallel alignment by laying a straight edge across the flanges at several locations around the circumference. Parallel misalignment must not exceed 1/32" (0.8 mm) maximum. For longest coupling life, it is always desirable to align coupling as accurately as possible at initial installation.

Table 1 - Alignment Measurements

Coupling No.	A (in)	B (in)
2-5/8	2-9/16	±1/16
3-1/4	2-7/8	±1/16
4	1-3/4	±5/64
5-1/4	2-1/4	±3/32
7	2-3/4	±1/8
8	3-1/8	±9/64
10	4-1/4	±11/64
Coupling No.	A (mm)	B (mm)
2-5/8	65.1	+/- 1.59
3-1/4	73.0	+/- 1.59
4	44.5	+/- 1.98
5-1/4	57.2	+/- 2.38
7	69.9	+/- 3.18
8	79.4	+/- 3.57
10	108.0	+/- 4.37

5. Install coupling guards per OSHA or applicable requirements. Guarding should be designed so that the coupling will be contained within the guard in the event the element is thrown from the coupling assembly.

Additional Instruction for Safe Installation and Use

1. All rotating parts should be guarded to prevent contact with foreign objects which could result in sparks, ignition, or damage to the coupling.
2. Couplings should be periodically inspected for normal wear, dust/dirt build up or any similar scenario that would impeded heat dissipation.
3. Increasing levels of vibration and noise could indicate the need for inspection, repair, or replacement of the coupling or element.
4. Electrical sparks are a source of ignition. To reduce the risk, proper electrical bonding and grounding is recommended. Polyurethane is not considered statically conductive. Redundant methods for grounding are the integrators responsibility.
5. Overloading may result in breakage or damage to the coupling or other equipment. As a result the coupling could become an explosion hazard. Damaged coupling components or elements must not be operated in hazardous environment.
6. Poly-Disc couplings are not intended to be used as thrust bearing members.



BALDOR
A MEMBER OF THE ABB GROUP

P.O. Box 2400, Fort Smith, AR 72902-2400 U.S.A., Ph: (1) 479.646.4711, Fax (1) 479.648.5792, International Fax (1) 479.648.5895

Dodge Product Support

6040 Ponders Court, Greenville, SC 29615-4617 U.S.A., Ph: (1) 864.297.4800, Fax: (1) 864.281.2433

www.baldor.com