

Instruction Manual for 2 15/16" through 3 7/16" DODGE® SLEEVOIL® SS* Plain-Water Cooled Pillow Blocks

These instructions must be read thoroughly before installation or operation. This instruction manual was accurate at the time of printing. Please see www.dodgeindustrial.com for updated instruction manuals.

WARNING: All products over 25 kg (55 lbs) are noted on the shipping package. Proper lifting practices are required for these products.

WARNING: To ensure that drive is not unexpectedly started, turn off and lock out or tag power source before proceeding. Failure to observe these precautions could result in bodily injury.

CAUTION: Do not scrape, rebabbitt or otherwise alter this product. Such action adversely affects bearing performance and may result in damage to or destruction of equipment.

INSTALLATION

1. Check **mounting structure** making sure it is rigid, level and well supported. Inspect shaft to insure it is smooth (32 micro-inch finish or better), within commercial tolerances and free of burrs or rough spots.
2. Disassemble and thoroughly clean all parts of the pillow block. Housing caps and liner caps are matched to their bases and should not be interchanged. Housing and liners should be interchanged as assemblies only.

WARNING: Rust preventatives and solvents can be toxic and/or flammable. Follow directions and safety procedures recommended by their manufacturers.

CAUTION: Liner assembly has critical machines surfaces which are easily damaged. Use care in handling to protect these surfaces. Liner parts should be placed on a soft, CLEAN surface.

3. Position **housing base** on pedestal so that oil gauge is in the position specified on the construction drawing. **Do not tighten housing base to pedestal.** Apply oil to the spherical seats in the housing base.
4. Set liner base in housing base and apply oil to liner bearing surface.

CAUTION: Care should be taken when reinstalling coolant pipes. Use pipe sealant and tighten securely. Over tightening may result in liner damage.

5. Apply oil to **shaft** in the bearing area and set shaft in place.
6. **Check alignment** of pillow block by noting clearance between housing and shaft at each end of the housing—clearance should be uniform within 1/32". Shim bearing pedestal where possible, otherwise use full length shims under base as required. Alignment of pillow block should be as accurate as possible. The self-alignment feature of the unit is to compensate for normal shaft deflection and possible setting of the supports.

WARNING: Because of the possible danger to persons(s) or property from accidents which may result from the improper use of products, it is important that correct procedures be followed. Products must be used in accordance with the engineering information specified in the catalog. Proper installation, maintenance and operation procedures must be observed. The instructions in the instruction manuals must be followed. Inspections should be made as necessary to assure safe operation under prevailing conditions. Proper guards and other suitable safety devices or procedures as may be desirable or as may be specified in safety codes should be provided, and are neither provided by Dodge nor are the responsibility of Dodge. This unit and its associated equipment must be installed, adjusted and maintained by qualified personnel who are familiar with the construction and operation of all equipment in the system and the potential hazards involved. When risk to persons or property may be involved, a holding device must be an integral part of the driven equipment beyond the speed reducer output shaft.

7. Place **oil rings** around outside of lower liner and over shaft. Secure and tighten screws. Oil ring halves are machined together and match marked. Upper and lower halves should not be changed with components from other oil rings. Make sure rings rotate freely on shaft.
8. Apply oil to bearing surface of **liner cap**. Locate cap in place on lower liner making sure oil ring is free to rotate.

*Short Series

The Sleeveoil liners 2-15/16" thru 3-7/16" have upper halves that are normally reversible on the lower half. By design, they are not doweled together and therefore not match-marked.

The only modification which requires match-marking of these 'PL-WC' liners, 2-15/16 and 3-7/16 is:

When Liners Have a Cylindrical Bore. (Since the location of the bore centerline to the liner dowels is then rigidly fixed, an upper liner reversed on a lower or interchanged halves from two different liners can severely change the clearances between shaft and liner bore.)

9. Tighten **housing base** to pedestal. Torque bolts to 2100 in-lb. Shaft should rotate freely.
10. **Size 2-15/16"** - Thread **dust seal** and **seal spring** into groove at end of housing base and around shaft. Hook ends of spring together; taking care not to overstress spring when stretching. Permanent set can cause loss of working load and looseness on shaft; resulting in oil leakage during operation.

Size 3-7/16" - Thread dust seal and seal retainer into groove at end of housing base and around shaft. Slide free end of seal retainer thru clasp and pull tightly. Hold clasp with screwdriver and pull free end of retainer as tightly as possible with pliers. If tightened properly, it will be difficult to move seal sideways. Cut off excess material, and discard it so it won't drop in housing bottom. Seal retainer may be disengaged before installation by inserting a straightened paper clip **between the bands** at the clasp and pulling the free end of the retainer out of the clasp. If unit is furnished with auxiliary seals, install a second seal on each end.

If using End Closure, neoprene discs should be installed at this time. **Consult construction drawing for type of seal recommended.**

11. Apply Gasket Eliminator to Sleeveoil housing base along outer contour of joint. Loosen plunger screw and locate housing cap on base taking care not to damage dust seals. To reduce chances for leakage, a non-hardening sealant must be used under cap bolts. Torque housing bolts to value given in Table 2. **The plunger screw must be loose until the housing bolts have been tightened.**

These Sleeveoil 'PL-WC' housings have match marks permanently stamped on the water grommet pad starting in June 1988. These match marks permanently insure that parts stay paired and critical orientation of assemblies is maintained.

12. **Cap Loaded Bearings:** Shaft must be held down to install cap, tighten plunger screw to recommended torque given in Table 2 with shaft held down. Mark position of plunger screw. Loosen plunger screw one complete turn and loosen shaft hold-down. Then tighten plunger screw while tightening shaft hold-down until plunger screw is tightened to the mark. Do not over-tighten shaft hold-down as this can misalign the bearing. Remove shaft hold-down and tighten plunger screw locknut.



NOTE: Do not tighten plunger screw on accompanying base loaded bearing until cap loaded bearing has been installed and hold-down removed.

Base Loaded Bearings: Tighten plunger screw to recommended torque given in Table 2 and tighten locknut.

IMPORTANT: Check and re-torque plunger screw to the specified torque after 24 hours of initial start-up and then check and re-torque periodically as required.

13. Install **Grommet** and **grommet washer**. Snug up grommet nut, not tight. If unit is to be cooled, connect flexible hose to water pipe in pillow block and to supply and drain lines. Use care to prevent kinks or sharp bends in flexible hose. A valve should be placed ahead of inlet and a sight drain should be used at outlet, if possible. Adjust coolant flow to suit conditions. Under average conditions very little coolant is required.

CAUTION: The water pressure should never exceed 120 p.s.i.

14. The **oil level gauge** may be located any distance from the pillow block by the use of a coupling and pipe of the desired length. The extended pipe must be supported so that it remains straight and perfectly level. **Use a spirit level—do not guess.** Use pipe sealer on all connections.
15. Remove all pipe plugs and flush liner bore and housing thoroughly with solvent or cleaner. Reinstall pipe plugs using pipe sealer. Tighten securely.
16. Each housing base has predrilled holes for doweling bearing to base plate.

LUBRICATION and OPERATION

Since the satisfactory operation of the pillow block depends almost entirely on the oil film being maintained between the shaft and liner bearing surface, it is recommended that a high grade straight mineral oil with rust and oxidation (R & O) inhibitors and anti-foam agents be used. Check equipment specifications for specific recommendations of oil viscosity by equipment manufacturer. Oil viscosity is determined by the equipment manufacturer and normally specified on the construction drawing.

Table 2

SLEEVOIL Size Standard	Oil Cap. Fl.-Oz.	Plunger Screw		Housing Cap Bolts	
		Wrench Size (Soc Hex)	Torque (In.-Lb.)	Thread Size	Torque (in.-Lb.)
2-15/16	18	5/8	450	5/8-11	1080
3-7/16	33	5/8	500	3/4-10	1920

Fill the pillow block with oil to the top of the center circle in the oil gauge. After placing into operation, remove inspection covers and check to make sure oil rings are bringing up oil. Operation should be checked frequently during the first few days. After some running of base loaded bearings only, loosen plunger screw 1/4 turn, then retighten as specified. This will allow the liner to align with the shaft. For cap loaded bearings, follow installation procedure. If noise develops, check alignment of housing, plunger screw and all operating parts. Check all points and make sure all screws and nuts are tightened after several days operation. **Maintain oil level above bottom of center circle at all times while unit is in operation.**

Oil Maintenance Schedule

Drain, flush, and refill with oil after 2 to 3 weeks of initial break-in operation. Since the satisfactory operation of the bearing depends entirely on an oil film being maintained between the shaft and the bearing liner surface, it is recommended that an oil analysis be performed at these regular intervals.

- Every 3 months for 24 hour/day service
- Every 6 months for 8 hour/day service

Acceptability of oil should be referred to the lubricant manufacturer. If oil quality is acceptable then repeat this procedure in three month intervals. Visually check oil for contamination between oil analysis checks. Oil service life depends upon several factors such as ambient conditions, operating temperature and frequency of bearing starts and stops. It is recommended that the oil be changed at least once per year for unfiltered static applications. Removing contaminants through the use of either the OLF-2 (Oil Level and Filtration) unit, Cool Lube 2, or a circulating oil system can extend oil service life. Consult equipment manufacturer for more information.

NOTE: The MINIMUM oil temperature at start-up is 70°F.

Oil film temperature in liner during operation should not exceed 180°F. If in doubt, consult equipment manufacturer.

Any question on installation, maintenance, or arrangement of coolant connection inlets and outlets should be referred to the original equipment manufacturer.

Pillow Block Material Details

Housing:	Class 30 Gray Cast Iron
Liner:	Class 30 Gray Cast Iron
Babbitt:	Lead or Tin Based Babbitt
Oil Rings:	Bronze
Aluminum Seal:	Sand Cast Aluminum
O-ring:	Elastomer Compound
Aux. Seal:	HNBR with Stainless Steel Retainer
Grommet:	Synthetic Rubber
Grommet Plate:	Carbon Steel
Pipe Nipple:	Carbon Steel
Oil Gauge:	Stainless Steel, Polypropylene
Hardware:	Carbon Steel
Plunger Screw:	Carbon Steel
Gasket Eliminator:	LOCTITE 515 Sealant

This Sleeveoil pillow block could contain lead in the bearing Babbitt material, please exercise proper precautions in the use, installation, dismantling and recycling of this unit.

Other Notes:

CAUTION: This product is not to be used for person moving applications.

NOTE: Care has been taken to keep instruction manuals accurate and timely. The most recent version of the instruction manual can be found on our website: www.dodgeindustrial.com

Weights:

Table 3 - Weight of SS PL-WC Pillow Blocks

R-series shaft size	Approximate Weights (lbs.)		
	Non-Expansion Pillow Block	Expansion Pillow Block	Liner Assembly
2-15/16	94	90	22
3-7/16	144	138	50

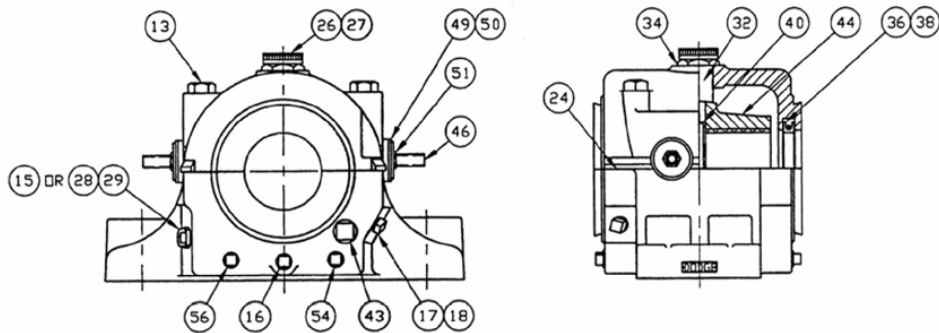

Reference	Name of Part	Number Required	Part Numbers	
			2-15/16	3-7/16
	Exp. Pillow Block	1	132991	132992
	Modular Housing ②	1	132995	132997
13	③ Housing Bolt	4	411147	411186
15	Oil Level Plug	1	430012	430012
16	Drain Plug	2	430010	430012
17	Thermocouple Plug	1	–	430012
18	Thermocouple Adapter	1	430081	430081
24	Gasket Eliminator	1	427359	427359
26	Inspection Cover ④	1	405005	405005
27	Nameplate	1	133267	133267
28	Oil Gauge	1	430139	430139
29	Oil Gauge Gasket	1	418110	418110
32	Plunger Screw	1	422397	422398
34	Plunger Screw Nut	1	133368	133368
①	Dust Seal Kit ⑤	1	389826	389827
36	③ Dust Seal	2	–	–
38	③ Seal Spring	2	–	–
40	Oil Ring	1	135724	135728
43	Circ Oil Drain Plug	1	–	430016
44	Liner Assembly ⑥	1	132950	132951
①	③ Brass Elbow	2	430068	430068
46	③ Water Pipe	2	430162	430162
49	Grommet	2	133021	133021
50	Grommet Washer	2	133025	133025
51	Grommet Nut	2	407254	407254
54	Thermostat / Accessory Plug	1	430008	430012
56	Heater Plug	1	–	430012
①	Heater / Thermostat Combo	1	–	434719
①	Flex Water Hose Kit	1	133344	133344
①	End Cover ⑦	⑦	133986	133987
①	Split End Plate ⑧	⑧	133129	–
①	End Plate Cap Screw		417047	–
①	Aux Dust Seal Kit	2	–	132811
①	Housing End Cap Kit	1	–	132542

① Not shown on drawing

② Includes housing cap and base, and parts listed immediately below

③ The parts marked are furnished with the assemblies under which they are listed

④ Nameplate ordered separately

⑤ Includes gasket eliminator and parts listed immediately below

⑥ Includes liner cap and base, and parts listed immediately below

⑦ Neoprene disc for use when desired, or installation where shaft does not extend through housing. 1 required for size 2-15/16, 2 required for size 3-7/16.

⑧ Auxiliary plate for bolting to one or both ends of housing where conditions are extremely dirty. Required one additional dust seal and seal spring per end plate. Requires special machining on housing.

Sleevoil Accessories

The following accessories are available for Sleevoil bearing to enhance operation and extend bearing life. For compatibility and technical information contact DODGE product support.



OIL LEVEL AND FILTRATION (OLF-2) SYSTEM

- Increase bearing longevity and reliability.
- One OLF-2 system supplies two bearings with a continuous flow of filtered oil.
- The oil is supplied directly to the circulating oil inlets on the bearings, which helps minimize wear during startups and shutdowns.



DODGE SLEEVOIL BEARING ISOLATOR

- Fully split multi-labyrinth sealing system.
- Provides outstanding protection in harsh and dirty environments.
- IP56 rated



RTD KIT

- Prevent catastrophes by accurately measuring bearing temperature.
- Features a field-cuttable stainless steel probe, a platinum sensing element and a spring-loaded fitting with an oil seal.



COOL LUBE 2

- All the features of the OLF-2 system plus a built-in heat exchanger for continuous oil cooling and adjustable oil flow controls.
- Particularly well suited in applications where bearing operating temperatures and speeds approach the maximum permissible levels.



HEATER/THERMOSTAT

- The bearing sump heater and thermostat have been combined into one user-friendly unit.
- Sump heaters are a necessity to ensure safe startups when bearings are exposed to ambient temperatures below 70°F.



THERMOMETER

- Dial thermometer for convenient monitoring of the oil sump temperature
- All stainless steel construction with glass face



COOLANT HOSE KIT

- An easy to install solution for connecting coolant lines to your Sleevoil bearing.
- Durable flexible hoses are composed of a synthetic rubber inner tube reinforced with fiber and steel braids.

Dodge Industrial, Inc.
1061 Holland Road
Simpsonville, SC 29681
+1 864 297 4800

