

PATENTED
PAT. <http://rbcm.biz/q=F3A63>

HERA[®]

HERA[®] HIGH-EFFICIENCY RIGHT ANGLE GEAR DRIVE TECHNICAL GUIDE

90% EFFICIENCY • 2X MORE TORQUE •
NO-HASSLE REPLACEMENT FOR WORM GEAR DRIVES

REGAL[®]

WHY HERA® GEAR DRIVES?

- Up to 40% more efficient than standard worm gearing
- Dimensionally interchangeable to up to 11 sizes of worm drives for inventory consolidation
- Available with a variety of Marathon® premium efficiency motors for even more energy savings (recommended)
- Bronze bushing quill liner to prevent fretting and for easy motor removal (56C & 143TC)
- Increased torque density and efficiency allow for downsizing of units and motors
- Filled with PAG460 premium synthetic lubricant for enhanced efficiency (Meets USDA H1)
- Viton* double lip seals protect against leaks at higher temperatures
- Longer life expectancy than that of standard worm gearing
- Rapid payback – Up to \$550 savings per year with each increment of motor HP
- Three year warranty
- Models HERA35 and HERA45 also available in stainless steel

Worm System

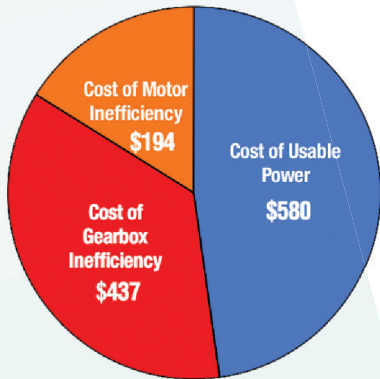

Annual Operating Cost (total): \$1,211
Based on internal test results

HERA System

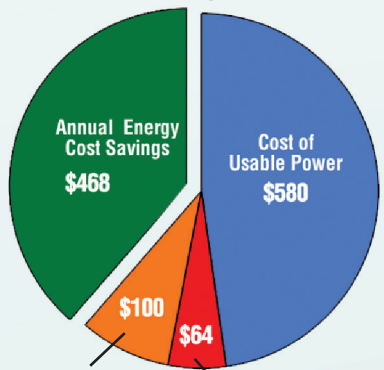

Annual Operating Cost (total): \$744
Based on internal test results

ONLINE TOOLS & APPS

HERA® SELECTOR

- Android and iPhone
- Select using physical parameters
- Select using competitor worm model number
- Shows unit and applicable kits, along with ratings
- Ask for HERA® Selector on iTunes or Google Play Marketplace



PRODUCT SEARCH & 3D MODEL CONFIGURATOR

- User friendly
- Quick navigation
- Native CAD files
- Find on the Hub City™ website under Tools > 3D Model Configurator & CAD

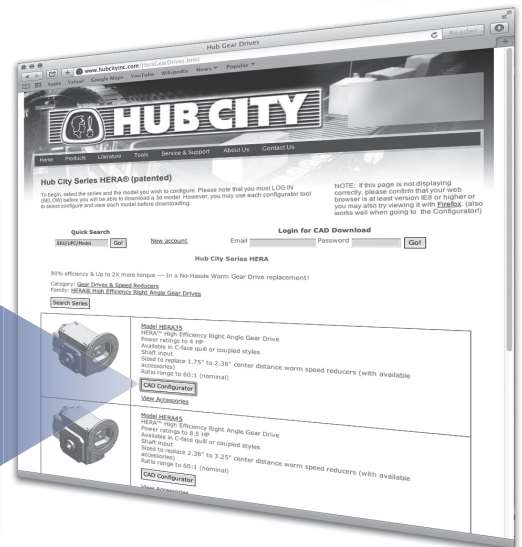

HERA GEAR DRIVE ORDERING INFORMATION

HERA45	E	S	28.01	143TC	(26)	1.438	0259-00096	0259-00083
Basic Model	Input Style	Output Style	Exact Ratio	Frame Size	Size Reference	Bore Size	Shaft Kit	B-Base Kit
HERA35 HERA45 HERA55 HERA75	A: Shaft Input E: C-face Quill P: C-face Coupled	S: (Sleeve) Hollow Bore K: Unit Accepts HubLoc® Keyless Bushing System	See Ratings Chart for Available Ratios	See Dimensional Table for Available Frame Sizes	Applies to (A) Shaft Input Only, see dimensional table for available sizes	See Stock Bores Table -OR- KLS: Unit Accepts HubLoc® Keyless Bushing System	See Accessories Pages For available Accessories	

*Viton is believed to be a trademark or trade name of The Chemours Company and is not owned or controlled by Regal Beloit Corporation.

RATINGS

SELECT BASIC MODEL

Using the rating chart below, select basic model and ratio based on application HP, service factor and output torque requirements (Please note color-coding for quick selection by motor HP). OR, if interchanging from competitor worm drive, use the interchange chart on back of this brochure to select the basic model.

BASIC MODEL QUICK SELECTION BY MOTOR HP (1.0 Service Factor @ 1750 RPM Input)

Nom. Ratio	1/2	3/4	1	1-1/2	2	3	5	7-1/2	10	15	20
7/1	35	35	35	35	35	35	45	45	55		
10/1	35	35	35	35	35	45	45	55	75	75	
15/1	35	35	35	35	35	45	45	55	75	75	
20/1	35	35	35	35	45	45	55	75	75		
30/1	35	35	35	45	45	55	75	75			
40/1	35	35	45	45	45	55	75				
50/1	35	45	45	45	55	75					
60/1	35	45	45	55	55	75					

Consult factory for high efficiency right angle drives suited for these power ratings.



Try the new
HERA® Selector
app for Android
and iPhone.

HERA® GEAR DRIVE POWER & TORQUE RATINGS (@ 1.0 Service Factor)

Nom. Ratio	INPUT RPM	Eff. (%)	HERA35			HERA45			HERA55			HERA75		
			Exact Ratio	Input HP	Output Torque (in. lbs.)	Exact Ratio	Input HP	Output Torque (in. lbs.)	Exact Ratio	Input HP	Output Torque (in. lbs.)	Exact Ratio	Input HP	Output Torque (in. lbs.)
7/1	2500	90	8.02	2.0	364	7.80	8.5	1504	7.94	13.0	2342	-	-	-
10/1	2500	90	11.42	2.0	518	11.36	7.5	1933	10.77	13.0	3177	9.58	18.0	3912
15/1	2500	90	15.60	2.0	708	15.60	7.0	2478	15.05	9.5	3244	15.05	15.0	5122
20/1	2500	90	19.93	2.0	905	19.50	5.9	2600	21.15	8.0	3839	21.15	13.0	6238
30/1	2500	90	29.10	1.7	1100	28.01	4.1	2600	30.14	6.6	4500	30.14	12.4	8500
40/1	2500	90	43.53	1.1	1100	39.98	2.9	2600	43.97	4.5	4500	37.33	10.0	8500
50/1	2500	90	52.50	0.9	1100	52.50	2.2	2600	53.03	3.7	4500	53.03	7.1	8500
60/1	2500	90	58.33	0.8	1100	59.79	1.9	2600	58.92	3.4	4500	58.92	6.4	8500
7/1	1750	90	8.02	4.2	1100	7.80	8.5	2149	7.94	13.0	3346	-	-	-
10/1	1750	90	11.42	3.0	1100	11.36	7.1	2600	10.77	13.0	4500	9.58	27.4	8500
15/1	1750	90	15.60	2.2	1100	15.60	5.1	2600	15.05	9.2	4500	15.05	17.4	8500
20/1	1750	90	19.93	1.7	1100	19.50	4.1	2600	21.15	6.6	4500	21.15	12.4	8500
30/1	1750	90	29.10	1.2	1100	28.01	2.9	2600	30.14	4.6	4500	30.14	8.7	8500
40/1	1750	90	43.53	0.8	1100	39.98	2.0	2600	43.97	3.2	4500	37.33	7.0	8500
50/1	1750	90	52.50	0.7	1100	52.50	1.5	2600	53.03	2.6	4500	53.03	5.0	8500
60/1	1750	90	58.33	0.6	1100	59.79	1.3	2600	58.92	2.4	4500	58.92	4.5	8500
7/1	1150	90	8.02	2.8	1100	7.80	6.8	2600	7.94	11.5	4500	-	-	-
10/1	1150	90	11.42	2.0	1100	11.36	4.6	2600	10.77	8.5	4500	9.58	18.0	8500
15/1	1150	90	15.60	1.4	1100	15.60	3.4	2600	15.05	6.1	4500	15.05	11.5	8500
20/1	1150	90	19.93	1.1	1100	19.50	2.70	2600	21.15	4.3	4500	21.15	8.2	8500
30/1	1150	90	29.10	0.8	1100	28.01	1.9	2600	30.14	3.0	4500	30.14	5.7	8500
40/1	1150	90	43.53	0.5	1100	39.98	1.3	2600	43.97	2.1	4500	37.33	4.6	8500
50/1	1150	90	52.50	0.4	1100	52.50	1.0	2600	53.03	1.7	4500	53.03	3.3	8500
60/1	1150	90	58.33	0.4	1100	59.79	0.9	2600	58.92	1.6	4500	58.92	2.9	8500
7/1	850	90	8.02	2.1	1100	7.80	5.0	2600	7.94	8.5	4500	-	-	-
10/1	850	90	11.42	1.4	1100	11.36	3.4	2600	10.77	6.3	4500	9.58	13.3	8500
15/1	850	90	15.60	1.1	1100	15.60	2.5	2600	15.05	4.5	4500	15.05	8.5	8500
20/1	850	90	19.93	0.8	1100	19.50	2.0	2600	21.15	3.2	4500	21.15	6.0	8500
30/1	850	90	29.10	0.6	1100	28.01	1.4	2600	30.14	2.2	4500	30.14	4.2	8500
40/1	850	90	43.53	0.4	1100	39.98	1.0	2600	43.97	1.5	4500	37.33	3.4	8500
50/1	850	90	52.50	0.3	1100	52.50	0.7	2600	53.03	1.3	4500	53.03	2.4	8500
60/1	850	90	58.33	0.3	1100	59.79	0.7	2600	58.92	1.1	4500	58.92	2.2	8500
7/1	100	90	8.02	0.2	1100	7.80	0.6	2600	7.94	1.0	4500	-	-	-
10/1	100	90	11.42	0.2	1100	11.36	0.4	2600	10.77	0.7	4500	9.58	1.6	8500
15/1	100	90	15.60	0.1	1100	15.60	0.3	2600	15.05	0.5	4500	15.05	1.0	8500
20/1	100	90	19.93	0.1	1100	19.50	0.2	2600	21.15	0.4	4500	21.15	0.7	8500
30/1	100	90	29.10	0.07	1100	28.01	0.2	2600	30.14	0.3	4500	30.14	0.5	8500
40/1	100	90	43.53	0.04	1100	39.98	0.1	2600	43.97	0.2	4500	37.33	0.4	8500
50/1	100	90	52.50	0.04	1100	52.50	0.09	2600	53.03	0.2	4500	53.03	0.3	8500
60/1	100	90	58.33	0.03	1100	59.79	0.08	2600	58.92	0.1	4500	58.92	0.3	8500

Additional ratios from 70/1 to 420/1 are available by adding a helical ratio multiplier to the HERA gear drive. See page 18.

Additional ratios from 86/1 to as high as 3,487/1 are available by ordering a DOUBLE HERA reducer assembly. See page 16.

SHAFT INPUT

**MODELS: HERA35AS, HERA45AS,
HERA55AS, HERA75AS**

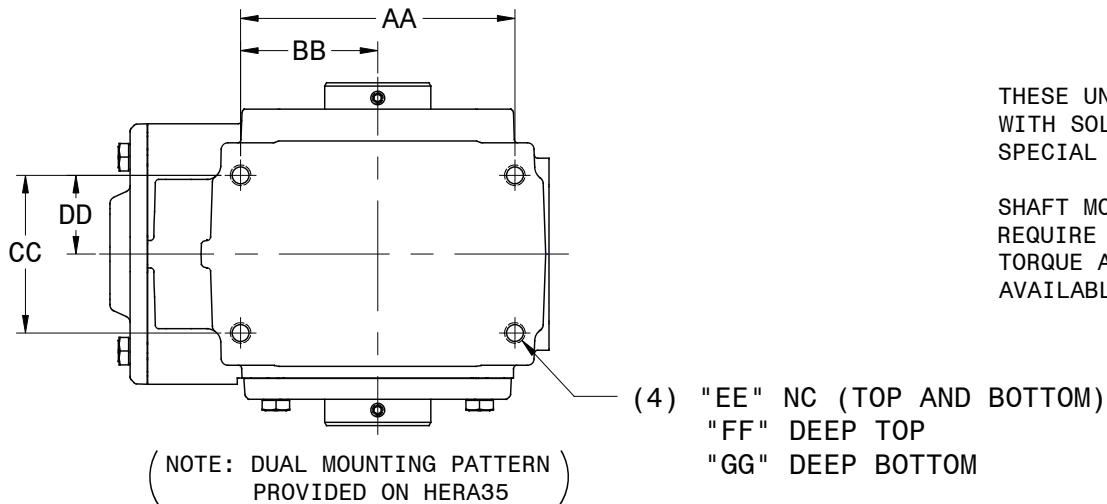
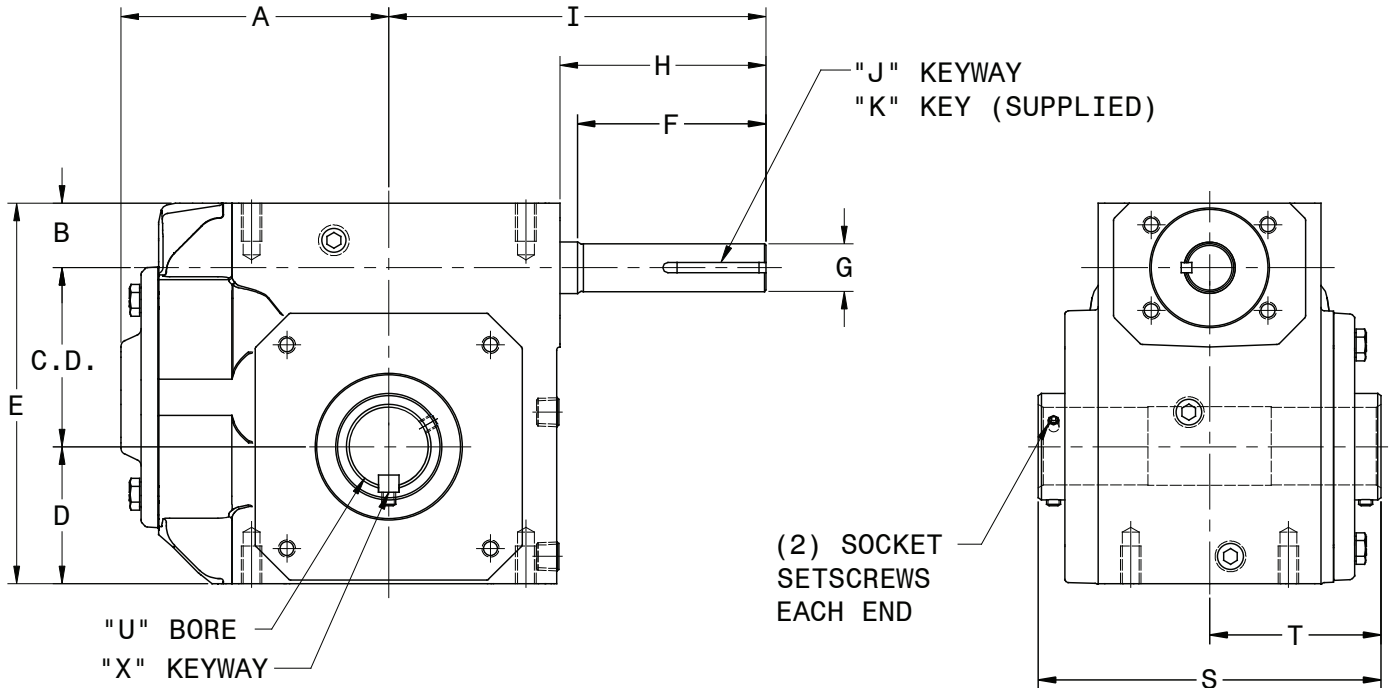

THESE UNITS CAN BE FURNISHED WITH SOLID OUTPUT SHAFT ON SPECIAL ORDERS.

SHAFT MOUNTED UNITS REQUIRE TORQUE ARMS. TORQUE ARM KITS ARE AVAILABLE. SEE PAGE 15

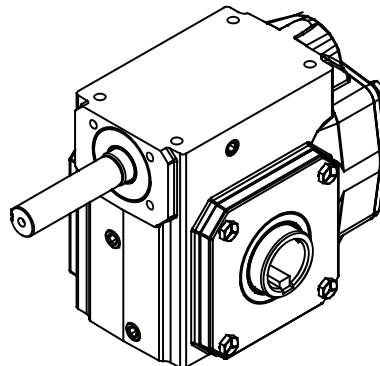
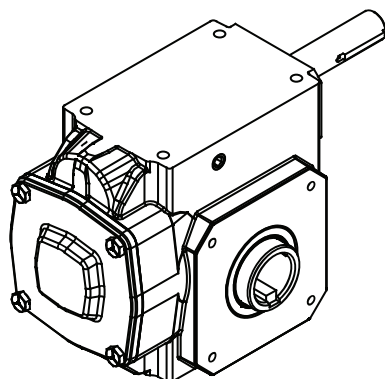

Download Available
CAD models at
www.hubcityinc.com

Dimensions shown are for reference only.
Consult factory at 605-225-0360 or hubsales@regalbeloit.com for vertical shaft lubrication recommendations.

MODELS: HERA35AS, HERA45AS, HERA55AS, HERA75AS

SHAFT INPUT

MODEL	C.D.	A	B	D	E	AA	BB	CC	DD	EE	FF	GG
HERA35AS	2.509	4.25	1.178	2.062	5.750	4.188	2.094	2.750	1.375	5/16 UNC	0.63	0.63
						5.000	2.500	2.875	1.438	3/8 UNC	0.69	0.69
HERA45AS	3.263	4.88	1.175	2.500	6.938	5.000	2.500	2.875	1.438	3/8 UNC	0.69	0.69
HERA55AS	3.675	6.15	2.200	3.500	9.375	7.500	3.750	4.000	2.000	7/16 UNC	0.88	0.88
HERA75AS	4.287	8.36	2.650	4.438	11.375	8.500	4.250	5.000	2.500	5/8 UNC	1.00	1.00

MODEL	SIZE REF.	F	G	H	I	J	K	Wt. Lbs.
HERA35AS	18	1.56	.6245/.6235	1.94	4.88	3/16 X 3/32	3/16 SQ X 1-1/4	28
	21	1.81		2.19	5.13		3/16 SQ X 1-1/2	
	24	2.00	.7495/.7485	2.38	5.31			
HERA45AS	24	2.00	.7495/.7485	2.38	5.50	3/16 X 3/32	3/16 SQ X 1-1/2	38
	26	2.81		3.19	6.31			
	30	3.44	.8745/.8735	3.76	6.88			
	32	4.00		4.32	7.44			
HERA55AS	32	2.07	.8745/.8735	2.38	6.75	3/16 X 3/32	3/16 SQ X 1-1/2	74
	38	3.70	.9995/.9985	4.01	8.38	1/4 X 1/8	1/4 SQ X 2-1/4	
	42	4.88	1.2495/1.2485	5.19	9.56			
HERA75AS	32	2.07	.8745/.8735	2.38	7.63	3/16 X 3/32	3/16 SQ X 1-1/2	161
	42	4.00	1.2495/1.2485	4.31	9.56	1/4 X 1/8	1/4 SQ X 2-1/4	
	52	5.00		5.44	10.69		1/4 SQ X 3	

STOCK BORES

MODEL	S	T	U	X	Key Furnished
HERA35AS	5.50	2.75	3/4	3/16 X 3/32	3/16 Sq.
				7/8	3/16 X 3/32
			1	1/4 X 1/8	1/4 Sq.
			1-1/8	1/4 X 1/8	1/4 Sq.
			1-3/16	1/4 X 1/8	1/4 Sq.
			1-1/4	1/4 X 1/8	1/4 Sq.
			1-7/16	3/8 X 1/8	3/8 X 5/16
			1	1/4 X 1/8	1/4 Sq.
HERA45AS	6.25	3.13	1-1/8	1/4 X 1/8	1/4 Sq.
				1-3/16	1/4 X 1/8
			1-1/4	1/4 X 1/8	1/4 Sq.
			1-7/16	3/8 X 1/8	3/8 X 5/16
			1-1/2	3/8 X 1/8	3/8 X 5/16
			1-3/16	1/4 X 1/8	1/4 Sq.
HERA55AS	7.50	3.75	1-1/4	1/4 X 1/8	1/4 Sq.
				1-7/16	3/8 X 3/16
			1-1/2	3/8 X 3/16	3/8 Sq.
			1-5/8	3/8 X 3/16	3/8 Sq.
			1-11/16	3/8 X 3/16	3/8 Sq.
			1-3/4	3/8 X 3/16	3/8 Sq.
			1-7/8	1/2 X 1/4	1/2 Sq.
			1-15/16	1/2 X 3/16	1/2 X 7/16
			2	1/2 X 3/16	1/2 X 7/16
			2-3/16	1/2 X 1/8	1/2 X 3/8

MODEL	S	T	U	X	Key Furnished
HERA75AS	9.50	4.75	1-7/16	3/8 X 3/16	3/8 Sq.
				1-1/2	3/8 X 3/16
			1-15/16	1/2 X 1/4	1/2 Sq.
			2	1/2 X 1/4	1/2 Sq.
			2-3/16	1/2 X 1/4	1/2 Sq.
			2-7/16	5/8 X 5/16	5/8 Sq.
			3	3/4 X 3/8	3/4 Sq.
			3-7/16	7/8 X 1/4	7/8 X 11/16

Bore tolerance nominal + .0025

Torque Arm Kits Required for Shaft Mounted Applications – See Page 15

QUILL INPUT

**MODELS: HERA35ES, HERA45ES,
HERA55ES, HERA75ES**

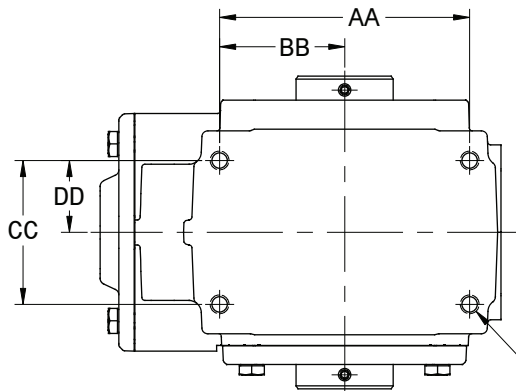
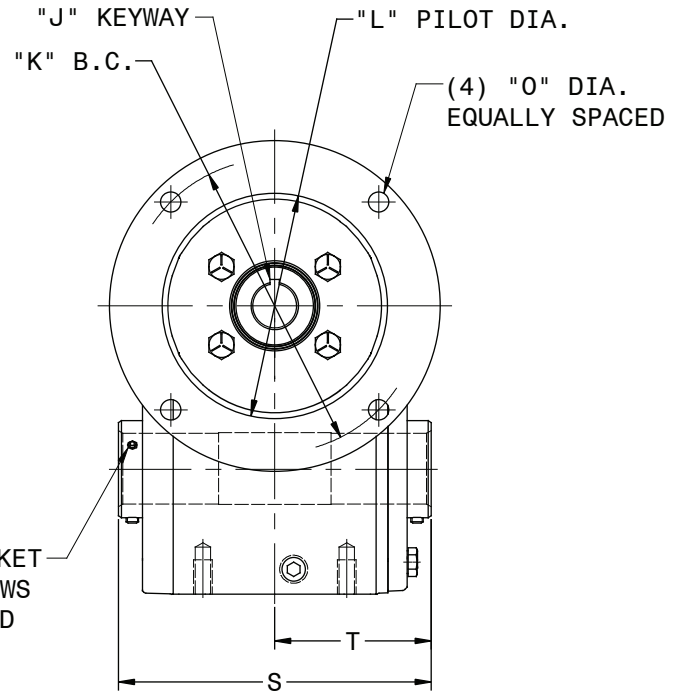
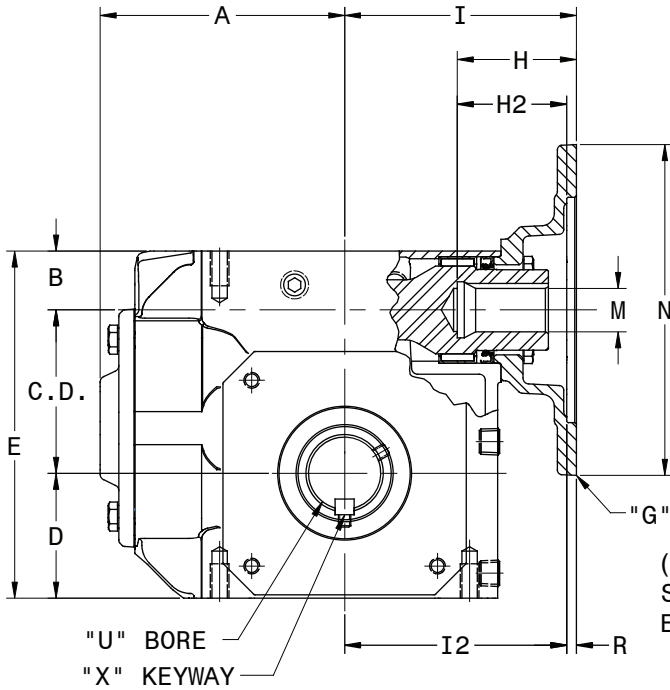

(NOTE: DUAL MOUNTING PATTERN PROVIDED ON HERA35)

(4) "EE" NC (TOP AND BOTTOM)
"FF" DEEP TOP
"GG" DEEP BOTTOM

SPECIAL, METRIC AND SAE HYDRAULIC INPUT FLANGES AVAILABLE. CONSULT FACTORY FOR COMPLETE SPECIFICATIONS.

THESE UNITS CAN BE FURNISHED WITH SOLID OUTPUT SHAFT ON SPECIAL ORDERS.

SHAFT MOUNTED UNITS REQUIRE TORQUE ARMS. TORQUE ARM KITS ARE AVAILABLE. SEE PAGE 15

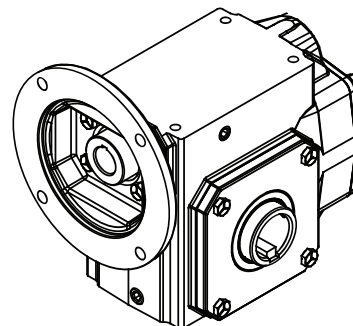
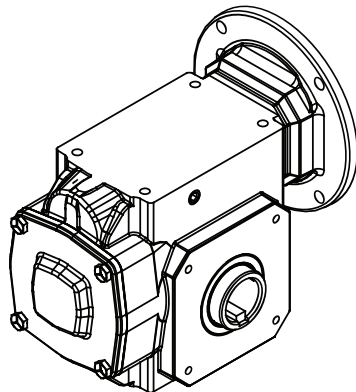

Download Available CAD models at www.hubcityinc.com

MODELS: HERA35ES, HERA45ES, HERA55ES, HERA75ES

QUILL INPUT

MODEL	C.D.	A	B	D	E	AA	BB	CC	DD	EE	FF	GG
HERA35ES	2.509	4.25	1.178	2.062	5.750	4.188	2.094	2.750	1.375	5/16 UNC	0.63	0.63
						5.000	2.500	2.875	1.438	3/8 UNC	0.69	0.69
HERA45ES	3.263	4.88	1.175	2.500	6.938	5.000	2.500	2.875	1.438	3/8 UNC	0.69	0.69
HERA55ES	3.675	6.15	2.200	3.500	9.375	7.500	3.750	4.000	2.000	7/16 UNC	0.88	0.88
HERA75ES	4.287	8.36	2.650	4.438	11.375	8.500	4.250	5.000	2.500	5/8 UNC	1.00	1.00

MODEL	G	H	H2	I	I2	J	K	L	M	N	O	R	Wt. Lbs.
HERA35ES	56C	2.27	N/A	4.44	N/A	3/16 X 3/32	5.875	4.501/4.503	0.625	6.61	13/32	0.188	30
	143TC	2.38							0.875				
HERA45ES	56C	2.27	N/A	4.63	N/A	3/16 X 3/32	5.875	4.501/4.503	0.625	6.61	13/32	0.188	42
	143TC	2.38							0.875				
	182TC	N/A	2.89	N/A	5.06	1/4 X 1/8	7.250	8.501/8.503	1.125	9.00	17/32	0.188	48
HERA55ES	56C	2.27	N/A	5.57	N/A	3/16 X 3/32	5.875	4.501/4.503	0.625	6.63	13/32	0.188	81
	143TC	2.38							0.875				
	182TC	N/A	2.89	N/A	6.33	1/4 X 1/8	7.250	8.501/8.503	1.125	9.00	17/32	0.188	88
	213TC		3.63			5/16 X 5/32			1.375				
	256TC		3.88			3/8 X 3/16			1.625				
HERA75ES	56C	2.27	N/A	6.45	N/A	3/16 X 3/32	5.875	4.501/4.503	0.625	6.63	13/32	0.188	164
	143TC	2.38							0.875				
	182TC	N/A	2.89	N/A	7.21	1/4 X 1/8	7.250	8.501/8.503	1.125	9.00	17/32	0.188	171
	213TC		3.63			5/16 X 5/32			1.375				
	256TC		3.88			3/8 X 3/16			1.625				

STOCK BORES

MODEL	S	T	U	X	Key Furnished
HERA35ES	5.50	2.75	3/4	3/16 X 3/32	3/16 Sq.
			7/8	3/16 X 3/32	3/16 Sq.
			1	1/4 X 1/8	1/4 Sq.
			1-1/8	1/4 X 1/8	1/4 Sq.
			1-3/16	1/4 X 1/8	1/4 Sq.
			1-1/4	1/4 X 1/8	1/4 Sq.
			1-7/16	3/8 X 1/8	3/8 X 5/16
			1	1/4 X 1/8	1/4 Sq.
HERA45ES	6.25	3.13	1-1/8	1/4 X 1/8	1/4 Sq.
			1-3/16	1/4 X 1/8	1/4 Sq.
			1-1/4	1/4 X 1/8	1/4 Sq.
			1-7/16	3/8 X 1/8	3/8 X 5/16
			1-1/2	3/8 X 1/8	3/8 X 5/16
			1-3/16	1/4 X 1/8	1/4 Sq.
HERA55ES	7.50	3.75	1-1/4	1/4 X 1/8	1/4 Sq.
			1-7/16	3/8 X 3/16	3/8 Sq.
			1-1/2	3/8 X 3/16	3/8 Sq.
			1-5/8	3/8 X 3/16	3/8 Sq.
			1-11/16	3/8 X 3/16	3/8 Sq.
			1-3/4	3/8 X 3/16	3/8 Sq.
			1-7/8	1/2 X 1/4	1/2 Sq.
			1-15/16	1/2 X 3/16	1/2 X 7/16
			2	1/2 X 3/16	1/2 X 7/16
			2-3/16	1/2 X 1/8	1/2 X 3/8

MODEL	S	T	U	X	Key Furnished
HERA75ES	9.50	4.75	1-7/16	3/8 X 3/16	3/8 Sq.
			1-1/2	3/8 X 3/16	3/8 Sq.
			1-15/16	1/2 X 1/4	1/2 Sq.
			2	1/2 X 1/4	1/2 Sq.
			2-3/16	1/2 X 1/4	1/2 Sq.
			2-7/16	5/8 X 5/16	5/8 Sq.
			3	3/4 X 3/8	3/4 Sq.
			3-7/16	7/8 X 1/4	7/8 X 11/16

Bore tolerance nominal + .0025

COUPLED INPUT

**MODELS: HERA35PS, HERA45PS,
HERA55PS, HERA75PS**

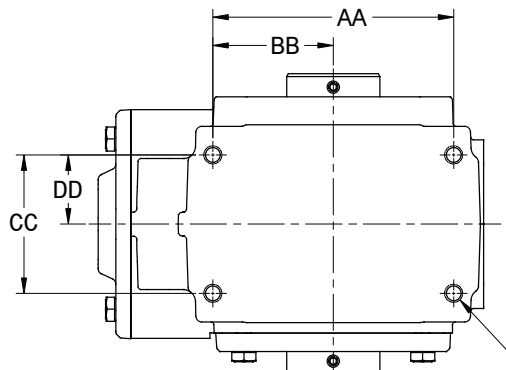
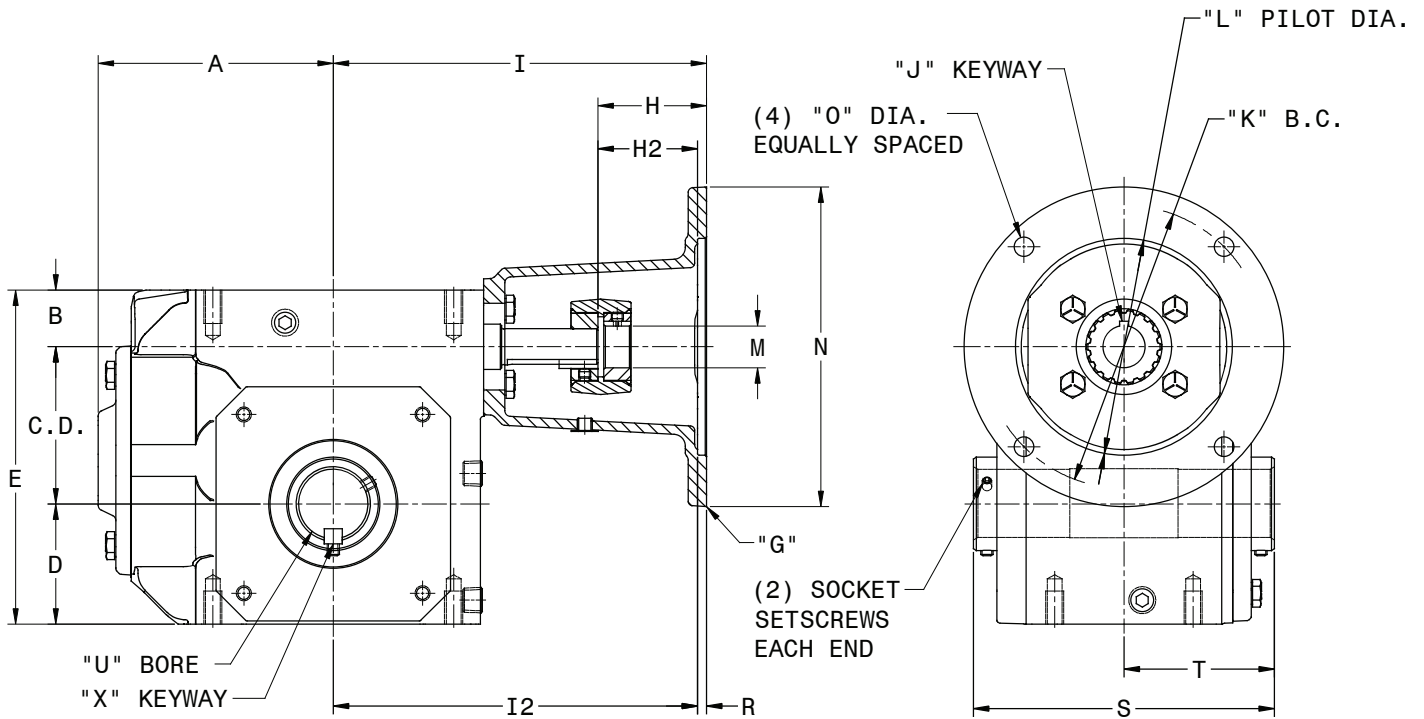

- (4) "EE" NC (TOP AND BOTTOM)
- "FF" DEEP TOP
- "GG" DEEP BOTTOM

(NOTE: DUAL MOUNTING PATTERN PROVIDED ON HERA35)

SPECIAL, METRIC AND SAE HYDRAULIC INPUT FLANGES AVAILABLE. CONSULT FACTORY FOR COMPLETE SPECIFICATIONS.

THESE UNITS CAN BE FURNISHED WITH SOLID OUTPUT SHAFT ON SPECIAL ORDERS.

SHAFT MOUNTED UNITS REQUIRE TORQUE ARMS. TORQUE ARM KITS ARE AVAILABLE. SEE PAGE 15

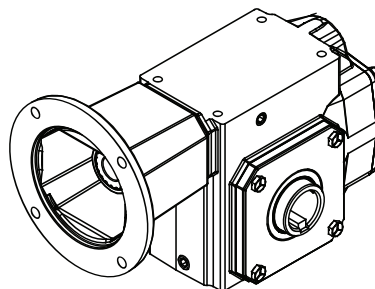
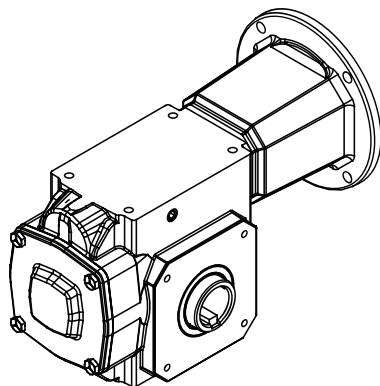

Download Available CAD models at www.hubcityinc.com

Dimensions shown are for reference only. Consult factory at 605-225-0360 or hubsales@regalbeloit.com for vertical shaft lubrication recommendations.

MODELS: HERA35PS, HERA45PS, HERA55PS, HERA75PS

COUPLED INPUT

MODEL	C.D.	A	B	D	E	AA	BB	CC	DD	EE	FF	GG
HERA35PS	2.509	4.25	1.178	2.062	5.750	4.188	2.094	2.750	1.375	5/16 UNC	0.63	0.63
						5.000	2.500	2.875	1.438	3/8 UNC	0.69	0.69
HERA45PS	3.263	4.88	1.175	2.500	6.938	5.000	2.500	2.875	1.438	3/8 UNC	0.69	0.69
HERA55PS	3.675	6.15	2.200	3.500	9.375	7.500	3.750	4.000	2.000	7/16 UNC	0.88	0.88
HERA75PS	4.287	8.36	2.650	4.438	11.375	8.500	4.250	5.000	2.500	5/8 UNC	1.00	1.00

MODEL	G	H	H2	I	I2	J	K	L	M	N	O	R	Wt. Lbs.
HERA35PS	56C	2.25	N/A	7.57	N/A	3/16 X 3/32	5.875	4.501/4.503	0.625	6.63	13/32	0.188	32
	143TC								0.875				
HERA45PS	56C	2.25	N/A	7.76	N/A	3/16 X 3/32	5.875	4.501/4.503	0.625	6.63	13/32	0.188	44
	143TC								0.875				
	182TC	N/A	3.25	N/A	8.76	1/4 X 1/8	7.250	8.501/8.503	1.125	9.00	17/32	0.188	54
HERA55PS	56C	2.25	N/A	9.00	N/A	3/16 X 3/32	5.875	4.501/4.503	0.625	6.50	13/32	0.188	83
	143TC								0.875				
	182TC	N/A	3.25	N/A	10.00	1/4 X 1/8	7.250	8.501/8.503	1.125	9.00	17/32	0.188	91
	213TC					5/16 X 5/32			1.375				
HERA75PS	56C	2.25	N/A	9.88	N/A	3/16 X 3/32	5.875	4.501/4.503	0.625	6.50	13/32	0.188	169
	143TC								0.875				
	182TC	N/A	3.25	N/A	10.88	1/4 X 1/8	7.250	8.501/8.503	1.125	9.00	17/32	0.188	178
	213TC					5/16 X 5/32			1.375				

STOCK BORES

MODEL	S	T	U	X	Key Furnished
HERA35PS	5.50	2.75	3/4	3/16 X 3/32	3/16 Sq.
			7/8	3/16 X 3/32	3/16 Sq.
			1	1/4 X 1/8	1/4 Sq.
			1-1/8	1/4 X 1/8	1/4 Sq.
			1-3/16	1/4 X 1/8	1/4 Sq.
			1-1/4	1/4 X 1/8	1/4 Sq.
			1-7/16	3/8 X 1/8	3/8 X 5/16
HERA45PS	6.25	3.13	1	1/4 X 1/8	1/4 Sq.
			1-1/8	1/4 X 1/8	1/4 Sq.
			1-3/16	1/4 X 1/8	1/4 Sq.
			1-1/4	1/4 X 1/8	1/4 Sq.
			1-7/16	3/8 X 1/8	3/8 X 5/16
			1-1/2	3/8 X 1/8	3/8 X 5/16
HERA55PS	7.50	3.75	1-3/16	1/4 X 1/8	1/4 Sq.
			1-1/4	1/4 X 1/8	1/4 Sq.
			1-7/16	3/8 X 3/16	3/8 Sq.
			1-1/2	3/8 X 3/16	3/8 Sq.

MODEL	S	T	U	X	Key Furnished
HERA55ES (Cont.)	7.50	3.75	1-5/8	3/8 X 3/16	3/8 Sq.
			1-11/16	3/8 X 3/16	3/8 Sq.
			1-3/4	3/8 X 3/16	3/8 Sq.
			1-7/8	1/2 X 1/4	1/2 Sq.
			1-15/16	1/2 X 3/16	1/2 X 7/16
			2	1/2 X 3/16	1/2 X 7/16
			2-3/16	1/2 X 1/8	1/2 X 3/8
			1-7/16	3/8 X 3/16	3/8 Sq.
HERA75ES	9.50	4.75	1-1/2	3/8 X 3/16	3/8 Sq.
			1-15/16	1/2 X 1/4	1/2 Sq.
			2	1/2 X 1/4	1/2 Sq.
			2-3/16	1/2 X 1/4	1/2 Sq.
			2-7/16	5/8 X 5/16	5/8 Sq.
			3	3/4 X 3/8	3/4 Sq.
			3-7/16	7/8 X 1/4	7/8 X 11/16

Bore tolerance nominal + .0025

NEMA "C" FLANGE ADAPTOR KITS

SERIES	BASE UNIT REQUIRED		"C-FLANGE KIT NO."	SHIPPING Wt. Lbs.	G
	MODEL	SIZE REF.			
HERA35	HERA35AS	24	0259-00079	12	56C
			0259-00080	12	143TC
HERA45	HERA45AS	24	0259-00079	12	56C
			0259-00080	12	143TC
			0259-00081	20	182TC
HERA55	HERA55AS	32	0259-00108	14	56C
			0259-00109	14	143TC
			0259-00110	22	182TC
			0259-00111	22	213TC
HERA75	HERA75AS	32	0259-00108	14	56C
			0259-00109	14	143TC
			0259-00110	22	182TC
			0259-00111	22	213TC

Nema®* C-flange adaptor kits can be ordered separately and attached to HERA__AS models. See chart for base unit requirements onto which they can be attached.

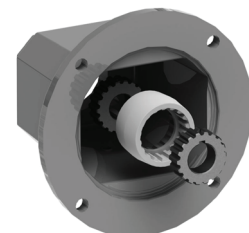

Torque Arm Kits Required for Shaft Mounted Applications – See Page 15

*NEMA is believed to be the trademark and/or trade name of National Electrical Manufacturers Association and is not owned or controlled by Regal Beloit Corporation.

SHAFT KITS

HERA® GEAR DRIVE ACCESSORIES

Plug-In Shaft Kits

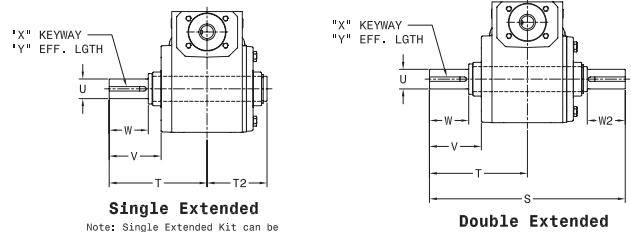

Single Extended
Note: Single Extended Kit can be installed from either side.

Double Extended

PLUG-IN SHAFT KITS

Series	Size Ref.	Stock Bore Required	Double Ext Kit No.	Single Ext Kit No.	S	T	T2	U	V	W	W2	X	Y	Key(s) Furnished	WT. LBS.
HERA35	18	1.438	0259-00135	0259-00136	8.62	4.31	2.97	.875	2.05	1.38	1.34	3/16 x 3/32	1.13	3/16 SQ X 1-1/8	4.1
	21		0259-00137	0259-00138	9.38	4.69	2.97	1.000	2.43	1.76	1.72	1/4 X 1/8	1.50	1/4 SQ X 1-1/2	4.4
	24		0259-00139	0259-00140	10.28	5.14	2.97	1.125	2.88	2.21	2.17	1/4 X 1/8	1.75	1/4 SQ X 1-3/4	4.9
HERA45	24	1.438	0259-00092	0259-00093	10.28	5.14	3.45	1.125	2.50	1.77	1.69	1/4 X 1/8	1.50	1/4 SQ X 1-1/2	5.2
	26		0259-00094	0259-00095	11.25	5.63	3.44	1.125	2.99	2.25	2.18	1/4 X 1/8	2.00	1/4 SQ X 1-3/4	5.7
	30		0259-00096	0259-00097	13.50	6.75	3.45	1.250	4.11	3.38	3.30	1/4 X 1/8	2.25	1/4 SQ X 2-1/4	6.6
	32		0259-00098	0259-00099	14.12	7.06	3.45	1.375	4.42	3.69	3.64	5/16 X 5/32	2.50	5/16 SQ X 2-3/8	7.3
HERA55	32	1.938	0259-00117	0259-00118	14.12	7.06	4.06	1.375	3.91	3.06	3.00	5/16 X 5/32	2.50	5/16 SQ X 2-3/8	10.0
	35		0259-00167	0259-00168	14.12	7.06	4.06	1.500	3.91	3.06	3.00	3/8 x 3/16	2.50	3/8 SQ X 2	10.0
	38		0259-00119	0259-00120	15.50	7.75	4.06	1.625	4.60	3.75	3.69	3/8 X 3/16	2.81	3/8 SQ X 2-1/2	11.8
	42		0259-00121	0259-00122	16.24	8.12	4.06	1.875	4.97	4.12	4.03	1/2 X 1/4	3.31	1/2 SQ X 3-1/4	13.8
HERA75	42	2.438	0259-00153	0259-00154	16.24	8.12	5.12	1.875	4.00	3.06	3.00	1/2 X 1/4	2.56	1/2 SQ X 2-1/2	TBD
	52		0259-00155	0259-00156	18.12	9.06	5.12	2.000	4.94	4.00	3.94	1/2 X 1/4	3.56	1/2 SQ X 3-1/2	TBD
	60		0259-00164	0259-00165	20.00	10.00	5.12	2.250	5.88	4.94	4.88	1/2 X 1/4	3.56	1/2 SQ X 3-1/2	TBD

BUSHING KITS

OUTPUT BUSHING KITS FOR HERA35 AND HERA45

Bushing Kit #	Bore Size Item #1	Key Item #2	Key Item #3	Set Screws Item #4
0259-00178	3/4	3/8 x 1/4 x 3	3/16 x 3/16 x 3	1/4-20 X 5/8
0259-00179	7/8	3/8 x 1/4 x 3	3/16 x 3/16 x 3	1/4-20 X 1/2
0259-00180	1	3/8 x 1/4 x 3	1/4 x 1/4 x 3	1/4-20 X 1/2
0259-00181	1-1/8	3/8-1/4 STEP x 3	N/A	1/4-20 X 1/2
0259-00182	1-3/16	3/8-1/4 STEP x 3	N/A	1/4-20 X 3/8
0259-00183	1-1/4	3/8-1/4 STEP x 3	N/A	1/4-20 X 3/8

Specifications are subject to change without notice

OUTPUT BUSHING KITS

Output bushing kits provide a means to adapt the stock bore hollow bore diameter to the most popular shaft diameters on driven equipment. Quick and easy installation. bushing kits fit both models HERA35 and HERA45.

Note: 1.438" stock bore required.

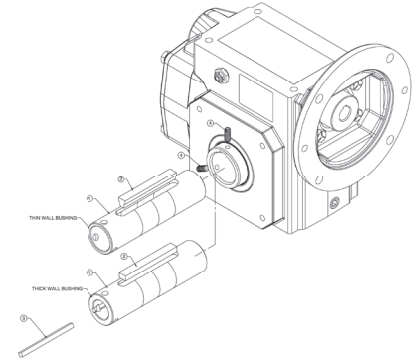

BRONZE OUTPUT BUSHING KITS

Bronze output bushing kits provide a means to adapt the stock bore hollow bore diameter to the most popular shaft diameters on driven equipment. Quick and easy installation. Bushing kits fit both models HERA35 and HERA45.

Note: 1.438" stock bore required.

Bushing kits include one drive bushing (keyed), one support bushing (non-keyed), keys and set screws for mounting.

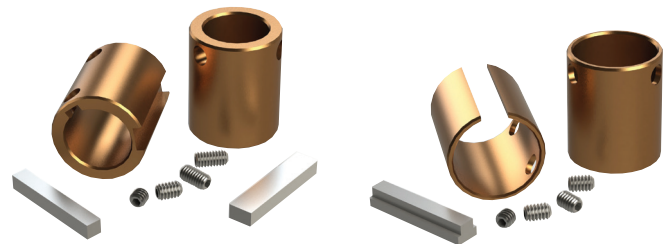

BRONZE OUTPUT BUSHING KITS

Series	Bushing Kit Number	Bore Size	Bushing Length	Driven Shaft Keyway
HERA35 & HERA45	0259-00256	1.000	(2) @ 2.00" ea.	3/16 x 3/32
HERA35 & HERA45	0259-00257	1.250	(2) @ 2.00" ea.	1/4 x 1/8

HUBLOC® KEYLESS BUSHING SYSTEM FEATURES:

- The HubLoc system creates a keyless, backlash-free mechanical interference fit that eliminates the micromovement that causes fretting and cold welding.
- Self-centering design achieves optimum concentricity and eliminates oscillation in shaft mounted applications.
- HubLoc system can be installed easily in a few minutes requiring only standard hand tools.
- Is easily uninstalled using threaded push-off holes.
- HubCap® protective covers are made from metal-detectable plastic to support customer HACCP programs. The blue color of the covers indicates that they are metal-detectable.

- Tamper resistant HubCap® protective covers are easily installed by hand and require a hand tool for removal. No additional hardware needed.
- The open HubCap cover is split so that it can be installed after bushing installation. The two cover halves snap together for easy installation by hand.
- HubCap closed cover kits can be ordered separately and fit both HERA35 and HERA45 models. Part #0259-00313.
- NEW – Heavy duty stainless steel safety covers available to provide an extra measure of protection where needed. In stock for Model HERA35 and HERA45 gear drives. Other sizes available on request.

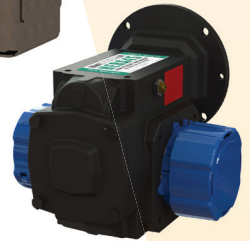
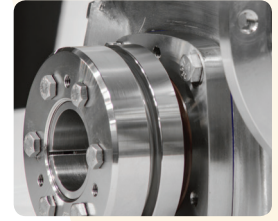

HUBLOC® KEYLESS BUSHING ORDERING INFORMATION

Step 1: Choose HubLoc Model based on your Product Line and Series/Model.

	Product Line	Series/Model	HubLoc Model
Cast Iron Products	HERA® Gear Drive	HERA35EK	HL10CS
		HERA45EK	HL10CS
		HERA55EK	HL40CS
		HERA75EK^	HL40CS
Stainless Steel Products	Stainless Steel HERA Gear Drive	SSHERA35EK	HL10SS
		SSHERA45EK	HL10SS

^ Model HERA75 requires special covers; consult factory at 605-225-0360 or hubsales@regalbeloit.com

STOCK MODEL DIMENSIONS

MODELS	A	B	C	D	E	F	G	OD
HERA35EK	4.66	4.25	2.40	4.53	0.41	0.16	4.28	3.23
HERA45EK	5.04	4.50	2.40	5.28	0.54	0.16	4.28	3.23
HERA55EK	6.26	5.32	3.11	6.3	0.94	0.16	5.23	4.02
SSHERA35EK	4.78	4.25	2.40	4.77	0.53	0.16	4.28	3.23
SSHERA45EK	5.04	4.50	2.40	5.28	0.54	0.16	4.28	3.23

Step 2: Choose HubLoc Kit based on HubLoc Model determined in Step 1, and bore size desired.

	HubLoc Model	Bores	HubLoc Kit Model
Carbon Steel HubLoc® Kits	HL10CS	1.000	HL10CS100K*
		1.188	HL10CS103K*
		1.250	HL10CS104K*
		1.375	HL10CS106K*
		1.438	HL10CS107K*
Stainless Steel HubLoc® Kits	HL40CS	1.250	HL40CS104K
		1.438	HL40CS107K*
		1.500	HL40CS108K
		1.938	HL40CS115K*
		2.000	HL40CS200K*
Stainless Steel HubLoc® Kits	HL10SS	1.000	HL10SS100K*
		1.188	HL10SS103K*
		1.250	HL10SS104K*
		1.375	HL10SS106K*
		1.438	HL10SS107K*
	HL40SS	1.250	HL40SS104K*
		1.438	HL40SS107K*
		1.938	HL40SS115K*
		2.000	HL40SS200K*

* Stock Kit.

HubLoc kit contains (2) bushings sets, (1) HubCap closed protective cover, and (1) HubCap open protective cover.

NEW: heavy duty stainless steel safety covers

SSHERA35 - CLOSED COVER KIT	0259-00294
SSHERA35 - OPEN COVER KIT	0259-00295
SSHERA45 - CLOSED COVER KIT	0259-00292
SSHERA45 - OPEN COVER KIT	0259-00293

Note: Stainless cover kits include hardware and covers for one side of unit. (open covers allow output shaft to protrude)

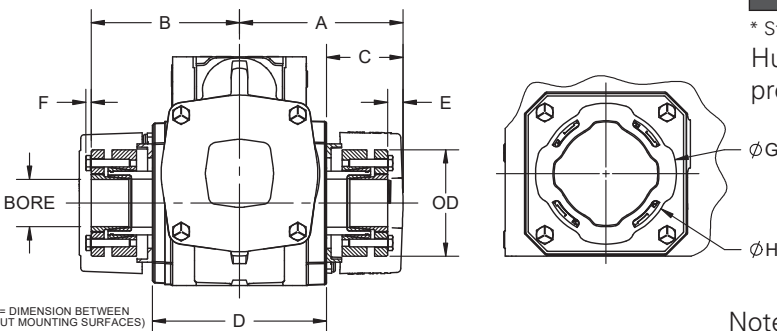

BASE KITS

HERA® GEAR DRIVE ACCESSORIES

- B - Base (required if interchanging to larger size worm gear reducer) provides appropriate "D" dimension and tapped mounting hole dimensions & pattern
- T - Base (includes B-base above) provides means to bolt unit from above mounting surface and matches competitor worm mounting base bolt patterns

Base Kits

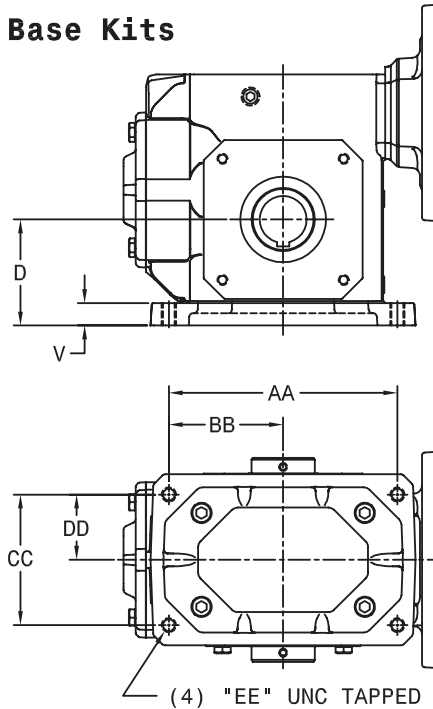

B-Base Kit

Hera B-bases provide a drop-in mounting solution when replacing comparable rated worm gear reducers.

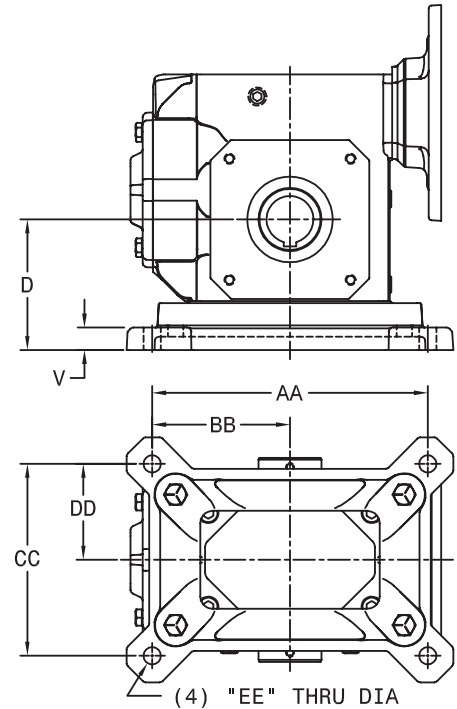

T-Base Kit

Hera T-bases provide a drop-in mounting solution when replacing comparable rated worm gear reducers that also are utilizing a horizontal mounting base.

B - BASE KITS

Series	B-Base Kit No.	Shipping Wt. Lbs.	Size Ref.	D	V	AA	BB	CC	DD	EE
HERA35	0259-00130	1.3	21	2.281	0.22	5.00	2.50	2.88	1.44	3/8 UNC
	0259-00131	2.0	24	2.500	0.38	5.00	2.50	2.88	1.44	3/8 UNC
HERA45	0259-00082	2.5	26	2.938	0.38	6.38	3.19	3.38	1.69	3/8 UNC
	0259-00083	4.3	30	3.25	0.69	7.00	3.50	4.00	2.00	7/16 UNC
	0259-00084	5.0	32	3.500	0.88	7.50	3.75	4.00	2.00	7/16 UNC
HERA55	0259-00276	4.0	35	3.990	0.49	7.50	3.75	4.00	2.00	7/16 UNC
	0259-00112	4.0	38	3.875	0.38	8.50	4.25	4.75	2.38	1/2 UNC
	0259-00113	7.5	42	4.438	0.88	8.50	4.25	5.00	2.50	5/8 UNC
HERA75	0259-00150	13	52	5.313	0.79	11.00	5.50	5.81	2.91	5/8 UNC
	0259-00162	21	60	6.500	1.50	12.75	6.38	6.38	3.19	5/8 UNC

T - BASE KITS

Series	T-Base Kit No.	Shipping Wt. Lbs.	Size Ref.	D	V	AA	BB	CC	DD	EE
HERA35	0259-00132	3.0	18	2.75	0.63	5.75	2.88	4.5	2.25	0.41
	0259-00133	4.8	21	3.000	0.66	6.38	3.19	4.69	2.34	0.47
	0259-00134	9.0	24	3.25	0.69	7.06	3.53	4.88	2.44	0.47
HERA45	0259-00186	6.0	24	3.25	0.69	7.06	3.53	4.88	2.44	0.47
	0259-00085	7.0	26	3.688	0.69	8.00	4.00	5.25	2.63	0.53
	0259-00086	9.5	30	4.000	0.69	8.44	4.22	5.88	2.94	0.53
HERA55	0259-00087	11.5	32	4.375	0.81	9.5	4.75	6.13	3.06	0.53
	0259-00114	6.5	32	4.375	0.81	9.5	4.75	6.13	3.06	0.53
	0259-00115	12.5	38	4.812	0.88	10.38	5.19	7.00	3.50	0.59
HERA75	0259-00116	19	42	5.438	0.94	11.13	5.56	7.63	3.81	0.66
	0259-00151	13	42	5.438	0.94	11.13	5.56	7.63	3.81	0.66
	0259-00152	27	52	6.438	1.06	14.13	7.06	8.38	4.19	0.78
	0259-00163	52	60	7.750	1.12	16.50	8.25	9.50	4.75	0.91

Specifications are subject to change without notice

RISER BLOCK KITS

Series	Kit No.	Shipping Wt. Lbs.	Size Ref.	C.D.	B	D2	V	AA	BB	CC	DD	EE
HERA35	0259-00170	6.2	17	2.509	1.17	5.99	0.63	5.75	2.88	4.5	2.25	0.41
	0259-00171	6.8	20			6.24	0.66	6.38	3.19	4.69	2.34	0.47
	0259-00172	13.1	23			7.88	0.69	7.06	3.53	4.88	2.44	0.47
HERA45	0259-00173	12.2	23	3.263	1.175	7.88	0.69	7.06	3.53	4.88	2.44	0.47
	0259-00174	14.5	26			8.21	0.69	8.00	4.00	5.25	2.63	0.53
	0259-00175	18.0	30			8.63	0.69	8.44	4.22	5.88	2.94	0.53
HERA55	0259-00176	20.0	35	3.675	2.200	9.27	0.81	9.50	4.75	6.13	3.06	0.53
	0259-00177	32.0	40			10.83	0.94	11.13	5.56	7.63	3.81	0.66

Riser block kits provide a clear top mounting surface above the motor flange for mounting below machine framework etc. Kits include T-base plates and mounting hardware.



Riser Block Kits

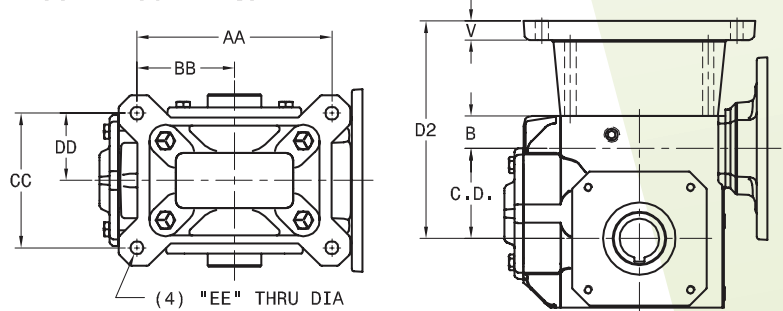

TOP MOUNTING KITS

Series	Kit No.	Shipping Wt. Lbs.	Size Ref.	C.D.	B	D2
HERA35	0223-07626	1.3	17	2.509	1.178	3.87
	0259-00131	2.0	20			4.13
HERA45	0259-00131	2.0	23	3.263	1.175	4.88
	0259-00288	4.5	26			5.49
	0259-00289	6.5	30			5.63
HERA55	0259-00290	6.0	35	3.675	2.200	6.58
	0259-00291	10.5	40			7.08

Top mounting kits are designed to match the mounting height from the output centerline to the mounting surface of top mounted Dodge* worm gear drives.

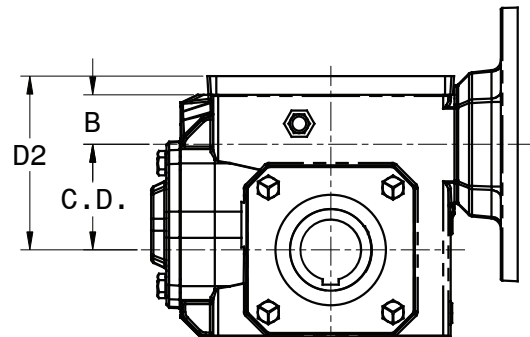
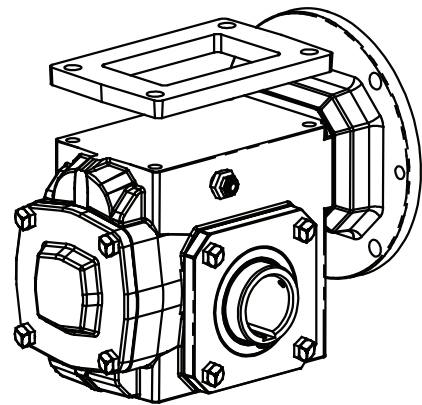

*Dodge is believed to be the trademark or trade name of ABB ASEA Brown Boveri, Ltd. and is not owned or controlled by Regal Beloit Corporation.

SIDE MOUNTS

F-FLANGE KITS

Series	F-Flange Kit No.	Shipping Wt. Lbs.	Size Ref.	S	T	Z	SS	TT	XX	YY
HERA35	0259-00141	8	18	0.44	2.75	3.19	0.38	5.00	0.34	5.88
	0259-00142	10	21	0.81	2.75	3.56	0.44	6.00	0.41	7.00
	0259-00143	10	24	0.75	2.75	3.50	0.44	6.27	0.41	7.50
HERA45	0259-00088	10	24	0.76	3.13	3.88	0.44	6.27	0.41	7.50
	0259-00089	12	26	0.31	3.13	3.44	0.50	6.67	0.41	8.00
	0259-00090	14	30	0.15	3.13	3.28	0.50	7.37	0.41	9.00
HERA55	0259-00123	15	32	0.04	3.75	3.79	0.50	7.37	0.41	9.00
	0259-00124	20	42	0.34	3.75	4.09	0.62	9.65	0.56	11.5
HERA75	0259-00157	20	42	0.31	4.75	5.06	0.62	9.65	0.56	11.5
	0259-00158	25	52	0.71	4.75	4.46	0.75	11.75	0.69	14.00
	0259-00166	30	60	1.82	4.75	6.57	0.75	SPEC	0.69	15.63

F-Flange Kits

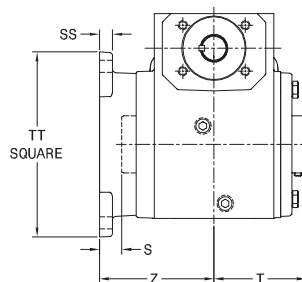
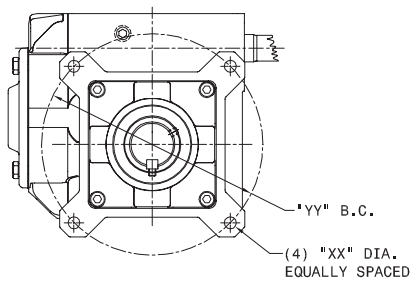

Note: Flange Kit can be installed on either side.



VERTICAL BASE KITS

Series	Vertical Base Kit No.	Shipping Wt. Lbs.	A	B	D	D1	F	G	H	J	K	V
HERA35	0259-00159	7	8.25	5	3	4.38	7.37	4.5	0.44	4	2	0.25
HERA45	0259-00106	10	9.94	6	3.38	5.25	8.81	5.38	0.5	4.88	2.44	0.38
HERA55	0259-00160	15	13	9	4.69	6.25	11.88	7.13	0.56	6.13	3.06	0.38
HERA75	0259-00161	35	16.26	10	5	7.5	14.88	8.69	0.69	7.88	3.94	0.5

Vertical Base Kits

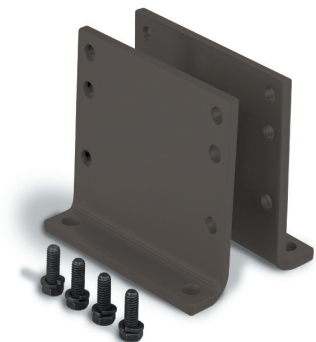
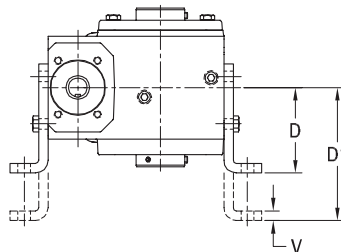
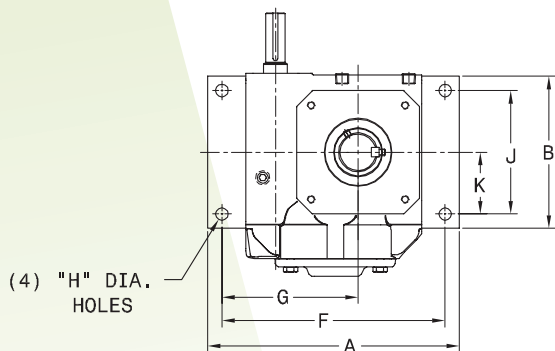

HERA® GEAR DRIVE ACCESSORIES

TORQUE ARM KITS

SERIES	TORQUE ARM KIT NO.	A	D	D2	Shipping WT. LBS.
HERA35	0259-00125	2.50	2.062	3.688	8.5
HERA45	0259-00078	3.25	2.500	4.438	9.0
HERA55	0259-00107	5.00	3.500	5.875	11.0
HERA75	0259-00144	5.00	4.438	6.937	13.0

Contact factory at 605-225-0360 or hubsales@regalbeloit.com for custom torque arm designs.

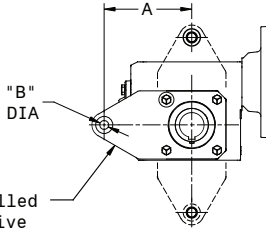
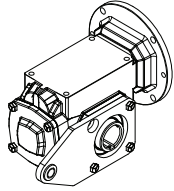

Torque plate can be installed on either side of gear drive in (3) possible orientations.

Bracket supplied with torque arm kit can be installed in (4) possible locations

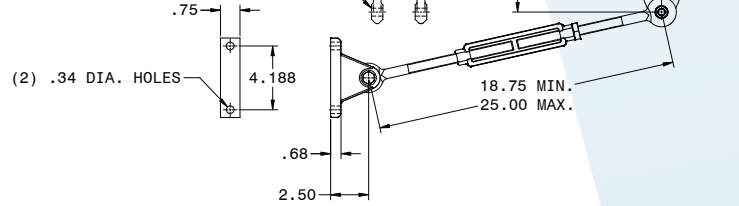

TORQUE ARMS

SIDE MOUNTED TORQUE PLATE KITS

SERIES	TORQUE PLATE KIT NO.	A	B	Shipping WT. LBS.
HERA35	0259-00286	5.12	0.53	3.0
HERA45	0259-00287	5.12	0.53	3.5
HERA55	0259-00309	8.50	0.53	8.0
HERA75	0259-00310	10.00	0.53	10.0

Does not include tie rod assembly

TECHNICAL

Model	OVERHUNG LOAD (LBS)*	THRUST LOAD (LBS)
HERA35	1500	1150
HERA45	1800	2100
HERA55	2200	2575
HERA75	3000	3400

Model	NORMAL BACKLASH			
	INCHES AT .75" RADIUS OF OUTPUT		ARC-MINUTES	
	MIN	MAX	MIN	MAX
All Models	0.002	0.006	9.2	27.5

*OHL Assumptions:

- 1) Load located at 1.5" from end of output sleeve (all models).
- 2) These values only account for bearing ratings and do not include stresses on plug-in or customer shafts used with the gear drive unit.

Consult factory at 605-225-0360 or hubsales@regalbeloit.com if OHL is expected to exceed above ratings.

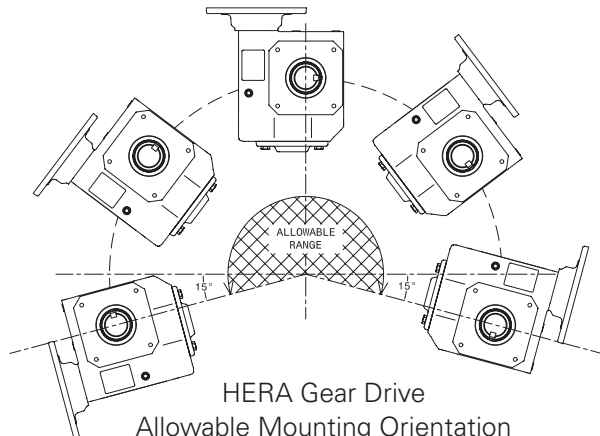

HERA Gear Drive Allowable Mounting Orientation (Without Factory Modification)

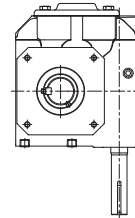

B6

- INPUT VERTICAL / DOWN -
- OUTPUT HORIZONTAL

NOT RECOMMENDED POSITION
(FACTORY MODIFICATIONS REQUIRED)

HERA® Gear Drive Special Mounting Orientations Requiring Factory Modification

FILL & BREATHER

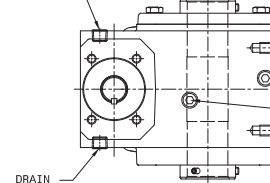

V5

- OUTPUT VERTICAL, COVER SIDE UP -
- INPUT HORIZONTAL

(FACTORY MODIFICATIONS REQUIRED)

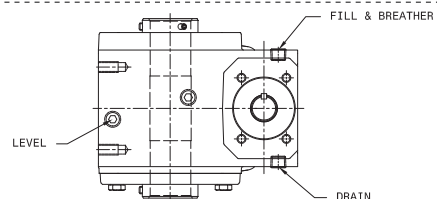

V6

- OUTPUT VERTICAL, COVER SIDE DOWN -
- INPUT HORIZONTAL

(FACTORY MODIFICATIONS REQUIRED)

DOUBLE HERA® SPEED REDUCER

POWER & TORQUE RATINGS

1750 RPM Input (1.0 SF), 80%
EFFICIENCY AT RATED TORQUE*

HERA3535

TOTAL RATIO	PRIMARY RATIO	SEC. RATIO	OUTPUT RPM	INPUT HP	OUTPUT TQ
91.6	8.02	11.42	19.1	0.42	1,100
125.1	8.02	15.60	14.0	0.31	1,100
130.4	11.42	11.42	13.4	0.29	1,100
159.8	8.02	19.93	11.0	0.24	1,100
178.2	11.42	15.60	9.8	0.21	1,100
243.4	15.60	15.60	7.2	0.16	1,100
311.0	15.60	19.93	5.6	0.12	1,100
332.4	11.42	29.10	5.3	0.11	1,100
348.9	8.02	43.53	5.0	0.11	1,100
397.3	19.93	19.93	4.4	0.10	1,100
420.9	8.02	52.50	4.2	0.09	1,100
454.0	15.60	29.10	3.9	0.08	1,100
467.6	8.02	58.33	3.7	0.08	1,100
497.1	11.42	43.53	3.5	0.08	1,100
599.6	11.42	52.50	2.9	0.06	1,100
679.0	15.60	43.53	2.6	0.06	1,100
819.0	15.60	52.50	2.1	0.05	1,100
867.6	19.93	43.53	2.0	0.04	1,100
910.0	15.60	58.33	1.9	0.04	1,100
1046.5	19.93	52.50	1.7	0.04	1,100
1162.8	19.93	58.33	1.5	0.03	1,100
1266.6	29.10	43.53	1.4	0.03	1,100
1527.8	29.10	52.50	1.1	0.02	1,100
1697.5	29.10	58.33	1.0	0.02	1,100
1894.5	43.53	43.53	0.9	0.02	1,100
2285.1	43.53	52.50	0.8	0.02	1,100
2539.0	43.53	58.33	0.7	0.02	1,100
2756.3	52.50	52.50	0.6	0.01	1,100
3062.5	52.50	58.33	0.6	0.01	1,100
3402.8	58.33	58.33	0.5	0.01	1,100

HERA4535

TOTAL RATIO	PRIMARY RATIO	SEC. RATIO	OUTPUT RPM	INPUT HP	OUTPUT TQ
91.1	8.02	11.36	19.2	0.99	2,600
125.1	8.02	15.60	14.0	0.72	2,600
156.3	8.02	19.50	11.2	0.58	2,600
178.2	11.42	15.60	9.8	0.51	2,600
243.4	15.60	15.60	7.2	0.37	2,600
304.2	15.60	19.50	5.8	0.30	2,600
320.5	8.02	39.98	5.5	0.28	2,600
420.9	8.02	52.50	4.2	0.21	2,600
456.6	11.42	39.98	3.8	0.20	2,600
494.5	43.53	11.36	3.5	0.18	2,600
558.3	19.93	28.01	3.1	0.16	2,600
599.6	11.42	52.50	2.9	0.15	2,600
682.9	11.42	59.79	2.6	0.13	2,600
796.8	19.93	39.98	2.2	0.11	2,600
819.0	15.60	52.50	2.1	0.11	2,600
932.8	15.60	59.79	1.9	0.10	2,600
1046.5	19.93	52.50	1.7	0.09	2,600
1163.3	29.10	39.98	1.5	0.08	2,600
1191.8	19.93	59.79	1.5	0.08	2,600
1527.8	29.10	52.50	1.1	0.06	2,600
1739.9	29.10	59.79	1.0	0.05	2,600
2285.1	43.53	52.50	0.8	0.04	2,600
2602.5	43.53	59.79	0.7	0.03	2,600
2756.3	52.50	52.50	0.6	0.03	2,600
3139.1	52.50	59.79	0.6	0.03	2,600
3487.8	58.33	59.79	0.5	0.03	2,600

HERA5535

TOTAL RATIO	PRIMARY RATIO	SEC. RATIO	OUTPUT RPM	INPUT HP	OUTPUT TQ
86.3	8.02	10.77	20.3	1.81	4,500
120.7	8.02	15.05	14.5	1.29	4,500
169.5	8.02	21.15	10.3	0.92	4,500
241.6	8.02	30.14	7.2	0.65	4,500
300.1	19.93	15.05	5.8	0.52	4,500
329.9	15.60	21.15	5.3	0.47	4,500
344.2	11.42	30.14	5.1	0.45	4,500
352.5	8.02	43.97	5.0	0.44	4,500
425.1	8.02	53.03	4.1	0.37	4,500
502.3	11.42	43.97	3.5	0.31	4,500
605.7	11.42	53.03	2.9	0.26	4,500
672.9	11.42	58.92	2.6	0.23	4,500
827.3	15.60	53.03	2.1	0.19	4,500
876.6	19.93	43.97	2.0	0.18	4,500
919.1	15.60	58.92	1.9	0.17	4,500
1057.1	19.93	53.03	1.7	0.15	4,500
1174.4	19.93	58.92	1.5	0.13	4,500
1279.7	29.10	43.97	1.4	0.12	4,500
1543.2	29.10	53.03	1.1	0.10	4,500
1714.5	29.10	58.92	1.0	0.09	4,500
1914.0	43.53	43.97	0.9	0.08	4,500
2308.2	43.53	53.03	0.8	0.07	4,500
2564.4	43.53	58.92	0.7	0.06	4,500
2784.1	52.50	53.03	0.6	0.06	4,500
3093.1	52.50	58.92	0.6	0.05	4,500
3436.8	58.33	58.92	0.5	0.05	4,500

HERA7535

TOTAL RATIO	PRIMARY RATIO	SEC. RATIO	OUTPUT RPM	INPUT HP	OUTPUT TQ
109.5	11.42	9.58	16.0	2.70	8,500
120.7	8.02	15.05	14.5	2.44	8,500
149.5	15.60	9.58	11.7	1.97	8,500
169.5	8.02	21.15	10.3	1.74	8,500
241.6	8.02	30.14	7.2	1.22	8,500
299.3	8.02	37.33	5.8	0.99	8,500
344.2	11.42	30.14	5.1	0.86	8,500
425.1	8.02	53.03	4.1	0.69	8,500
472.3	8.02	58.92	3.7	0.62	8,500
503.1	52.50	9.58	3.5	0.59	8,500
605.7	11.42	53.03	2.9	0.49	8,500
672.9	11.42	58.92	2.6	0.44	8,500
744.2	19.93	37.33	2.4	0.40	8,500
827.3	15.60	53.03	2.1	0.36	8,500
877.0	29.10	30.14	2.0	0.34	8,500
919.1	15.60	58.92	1.9	0.32	8,500
1057.1	19.93	53.03	1.7	0.28	8,500
1174.4	19.93	58.92	1.5	0.25	8,500
1543.2	29.10	53.03	1.1	0.19	8,500
1714.5	29.10	58.92	1.0	0.17	8,500
1960.0	52.50	37.33	0.9	0.15	8,500
2308.2	43.53	53.03	0.8	0.13	8,500
2564.4	43.53	58.92	0.7	0.12	8,500
2784.1	52.50	53.03	0.6	0.11	8,500
3093.1	52.50	58.92	0.6	0.10	8,500
3436.8	58.33	58.92	0.5	0.09	8,500

*Estimated - Actual may vary depending on application conditions

Output TQ measured in IN-LB.

Other total ratios available, consult factory at 605-225-0360 or hubsales@regalbeloit.com.

NOTE: All ratios will backdrive due to high efficiency gearing

ASSEMBLY DIMENSIONS

DOUBLE HERA® SPEED REDUCER

SERIES: HERA3535, HERA4535, HERA5535, & HERA7535

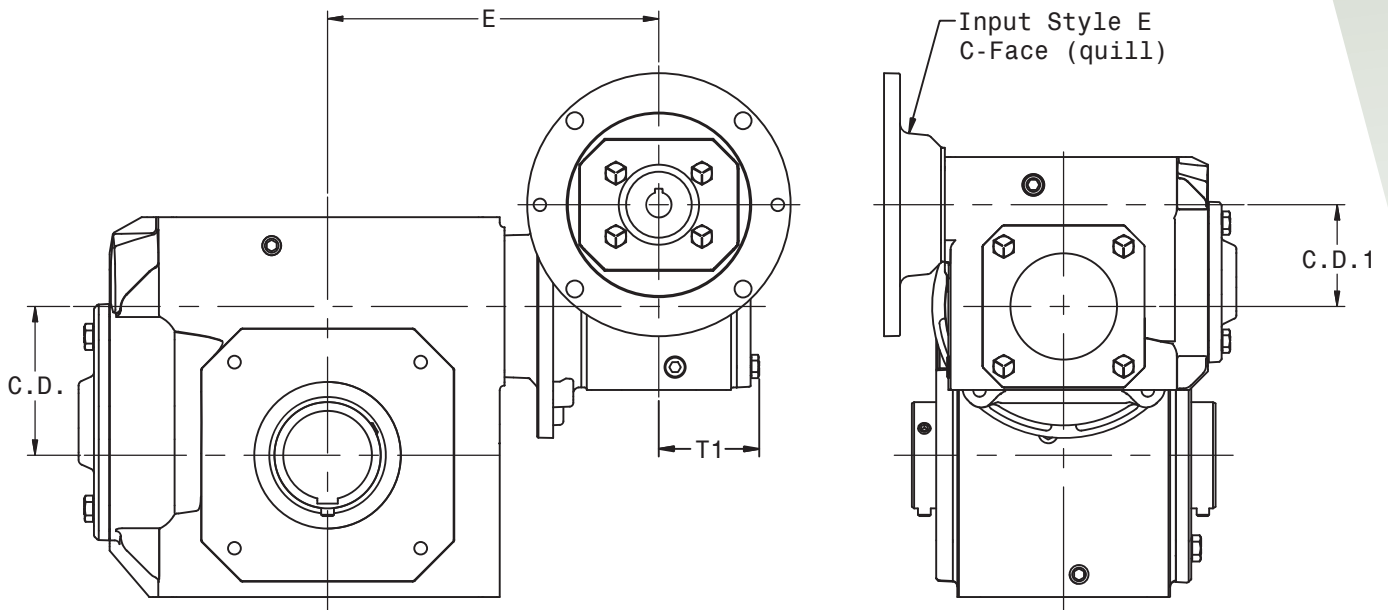

SERIES	PRIMARY	SECONDARY	C.D.	C.D. 1	E	T1
HERA3535	HERA35	HERA35	2.509	2.509	7.05	2.48
HERA4535	HERA35	HERA45	3.263	2.509	7.24	2.48
HERA5535	HERA35	HERA55	3.675	2.509	8.18	2.48
HERA7535	HERA35	HERA75	4.287	2.509	9.06	2.48

Dimensions shown are for reference only.

Download available CAD models at www.Hubcityinc.com.

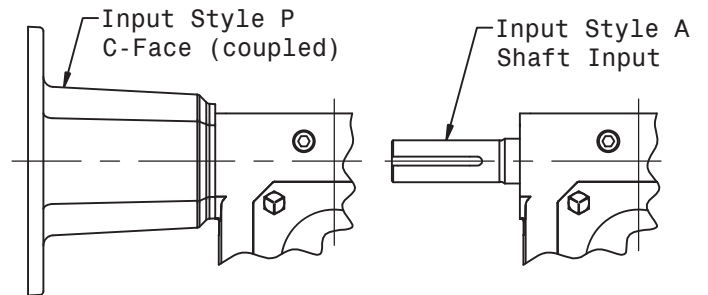

STANDARD STYLES AVAILABLE

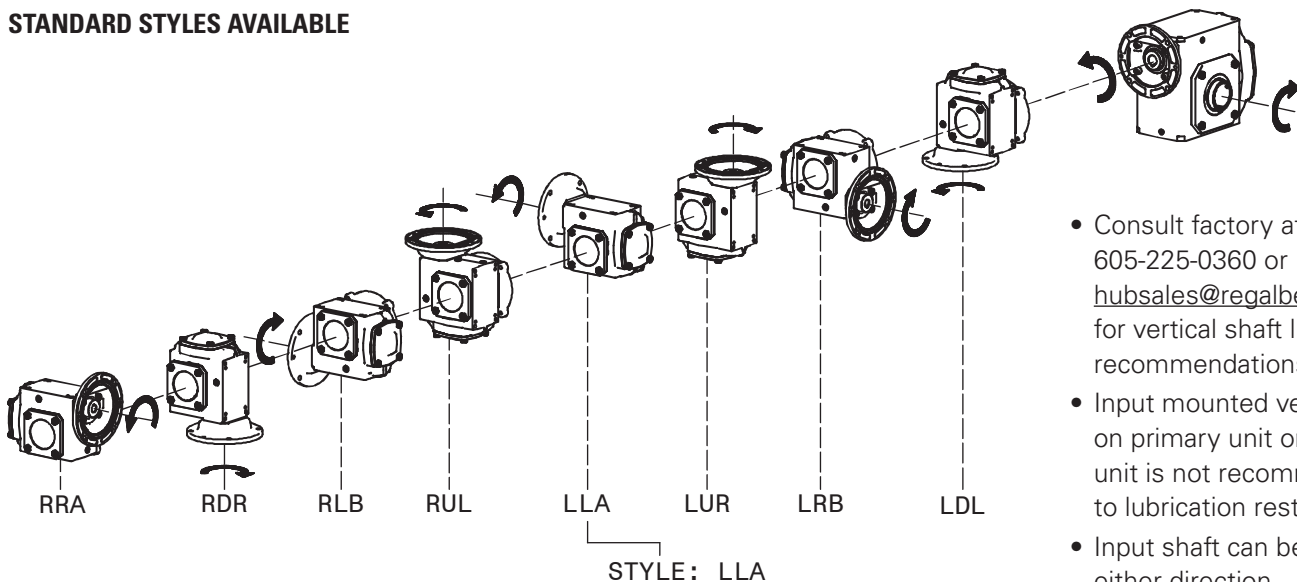

- Consult factory at 605-225-0360 or hubsales@regalbeloit.com for vertical shaft lubrication recommendations
- Input mounted vertical/down on primary unit or secondary unit is not recommended due to lubrication restrictions
- Input shaft can be rotated in either direction

COMPOUND HERA®

HELICAL-HERA COMPOUND SPEED REDUCER ASSEMBLIES

A helical ratio multiplier when coupled with a C-faced HERA® gear drive (see illustration) can create an efficient compound speed reducer assembly. Please refer to rating chart example below for selection instructions.

Note: See Catalog page F-7 for dimensions and available frame sizes of helical ratio multipliers, and pages 6 to 9 of this brochure for dimensions and available frame sizes of HERA models. Units should be ordered separately. Also see page F-6 for ratings of helical ratio multipliers as stand alone parallel shaft reducers.

MECHANICAL RATINGS

Ratings @ 1750 RPM input, 1.00 service factor

Use charts below when coupling a helical ratio multiplier with a HERA gear drive.

TOTAL RATIO	OUTPUT RPM	HERA MODEL	HERA RATIO	ARM1X RATIO	INPUT HP	OUTPUT TORQUE
74.66	23.4	HERA75	37.33	2.000	3.70	8,500
78.00	22.4	HERA45	19.50	4.000	1.08	2,600
79.72	22.0	HERA35	19.93	4.000	0.45	1,100
82.02	21.3	HERA35	11.42	7.182	0.44	1,100

1. Select Total Ratio desired

2. Select by Input HP or Output Tq required for your application

3. Order C-face model of HERA model and ratio listed here

4. Order ARM1X model and ratio listed here

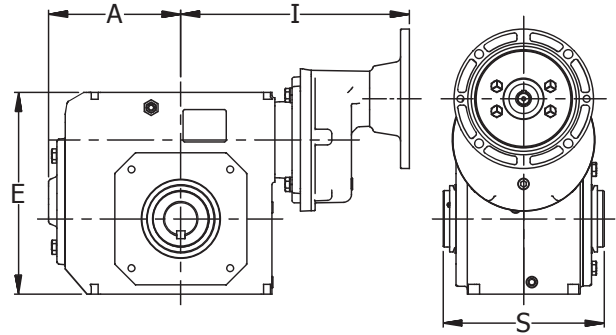

HERA Model	HELICAL RATIO MULTIPLIER MODEL	A	E	I*	S
HERA35	ARM1X	4.25	5.750	9.50	5.50
HERA45	ARM1X	4.88	6.938	9.69	6.25
HERA55	ARM1X	6.15	9.375	10.63	7.50
HERA75	ARM1X	8.36	11.375	11.51	9.50

* Dimension given for quill input helical ratio multiplier. See page F-7 for other input styles available.

Note: input frame size of HERA gear drive must match output frame size of helical ratio multiplier (see dimensional pages referenced for available frame sizes).

TOTAL RATIO	OUTPUT RPM	HERA® MODEL	HERA® RATIO	ARM1X RATIO	INPUT HP	OUTPUT TORQUE
79.72	22.0	HERA35	19.93	4.000	0.45	1,100
82.02	21.3		11.42	7.182	0.44	1,100
84.77	20.6		29.10	2.913	0.42	1,100
87.06	20.1		43.53	2.000	0.41	1,100
99.65	17.6		19.93	5.000	0.36	1,100
105.00	16.7		52.50	2.000	0.34	1,100
112.04	15.6		15.60	7.182	0.32	1,100
116.40	15.0		29.10	4.000	0.31	1,100
126.80	13.8		43.53	2.913	0.28	1,100
145.50	12.0		29.10	5.000	0.25	1,100
152.93	11.4		52.50	2.913	0.23	1,100
169.92	10.3		58.33	2.913	0.21	1,100
174.12	10.1		43.53	4.000	0.21	1,100
210.00	8.3		52.50	4.000	0.17	1,100
217.65	8.0		43.53	5.000	0.16	1,100
233.32	7.5		58.33	4.000	0.15	1,100
262.50	6.7		52.50	5.000	0.14	1,100
291.65	6.0		58.33	5.000	0.12	1,100
312.63	5.6	43.53	7.182	0.11	1,100	
377.06	4.6	52.50	7.182	0.09	1,100	
418.93	4.2	58.33	7.182	0.09	1,100	
78.00	22.4	HERA45	19.50	4.000	1.08	2,600
97.50	17.9		19.50	5.000	0.87	2,600
105.00	16.7		52.50	2.000	0.80	2,600
112.04	15.6		28.01	4.000	0.75	2,600
112.04	15.6		15.60	7.182	0.75	2,600
116.46	15.0		39.98	2.913	0.73	2,600
119.58	14.6		59.79	2.000	0.71	2,600
140.05	12.5		28.01	5.000	0.60	2,600
152.93	11.4		52.50	2.913	0.55	2,600
159.92	10.9		39.98	4.000	0.53	2,600
174.17	10.0		59.79	2.913	0.48	2,600
199.90	8.8		39.98	5.000	0.42	2,600
210.00	8.3		52.50	4.000	0.40	2,600
239.16	7.3		59.79	4.000	0.35	2,600
262.50	6.7		52.50	5.000	0.32	2,600
287.14	6.1		39.98	7.182	0.29	2,600
298.95	5.9		59.79	5.000	0.28	2,600
377.06	4.6		52.50	7.182	0.22	2,600
429.41	4.1	59.79	7.182	0.20	2,600	

Output Torque measured in IN-LB.

NOTE: All ratios will backdrive due to high efficiency gearing.

TOTAL RATIO	OUTPUT RPM	HERA MODEL	HERA RATIO	ARM1X RATIO	INPUT HP	OUTPUT TORQUE
75.25	23.3	HERA55	15.05	5.000	1.94	4,500
84.60	20.7		21.15	4.000	1.73	4,500
87.80	19.9		30.14	2.913	1.66	4,500
106.06	16.5		53.03	2.000	1.38	4,500
108.09	16.2		15.05	7.182	1.35	4,500
117.84	14.9		58.92	2.000	1.24	4,500
120.56	14.5		30.14	4.000	1.21	4,500
128.08	13.7		43.97	2.913	1.14	4,500
150.70	11.6		30.14	5.000	0.97	4,500
154.48	11.3		53.03	2.913	0.95	4,500
171.63	10.2		58.92	2.913	0.85	4,500
175.88	9.9		43.97	4.000	0.83	4,500
212.12	8.3		53.03	4.000	0.69	4,500
216.47	8.1		30.14	7.182	0.68	4,500
219.85	8.0		43.97	5.000	0.66	4,500
235.68	7.4		58.92	4.000	0.62	4,500
265.15	6.6		53.03	5.000	0.55	4,500
294.60	5.9		58.92	5.000	0.50	4,500
315.79	5.5	43.97	7.182	0.46	4,500	
380.86	4.6	53.03	7.182	0.38	4,500	
423.16	4.1	58.92	7.182	0.35	4,500	
74.66	23.4	HERA75	37.33	2.000	3.70	8,500
84.60	20.7		21.15	4.000	3.26	8,500
87.80	19.9		30.14	2.913	3.14	8,500
106.06	16.5		53.03	2.000	2.60	8,500
108.74	16.1		37.33	2.913	2.54	8,500
117.84	14.9		58.92	2.000	2.34	8,500
120.56	14.5		30.14	4.000	2.29	8,500
149.32	11.7		37.33	4.000	1.85	8,500
150.70	11.6		30.14	5.000	1.83	8,500
151.90	11.5		21.15	7.182	1.82	8,500
154.48	11.3		53.03	2.913	1.79	8,500
171.63	10.2		58.92	2.913	1.61	8,500
186.65	9.4		37.33	5.000	1.48	8,500
212.12	8.3		53.03	4.000	1.30	8,500
216.47	8.1		30.14	7.182	1.28	8,500
235.68	7.4		58.92	4.000	1.17	8,500
265.15	6.6		53.03	5.000	1.04	8,500
268.10	6.5		37.33	7.182	1.03	8,500
294.60	5.9	58.92	5.000	0.94	8,500	
380.86	4.6	53.03	7.182	0.72	8,500	
423.16	4.1	58.92	7.182	0.65	8,500	

WORM REDUCER INTERCHANGE

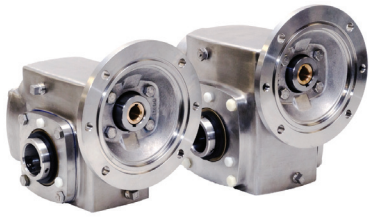

HERA35 & HERA45 models also available in stainless steel!

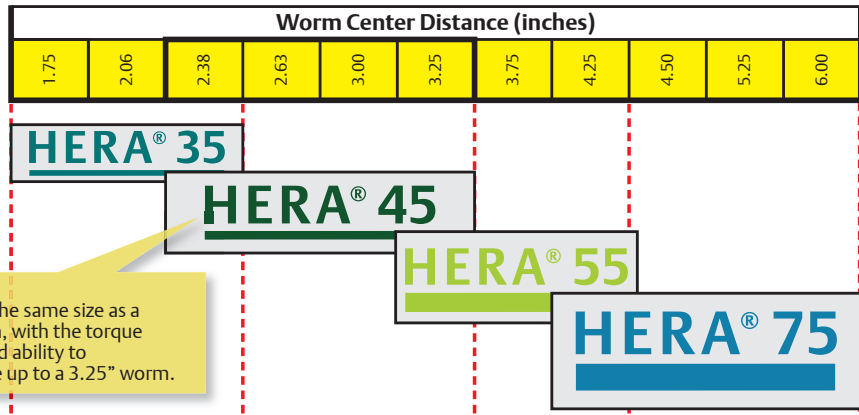

Example:
HERA45 is the same size as a 2.38" worm, with the torque capacity and ability to interchange up to a 3.25" worm.

Output Torque >> 1,100 in-lbs 2,600 in-lbs 4,500 in-lbs 8,500 in-lbs

COMPETITOR INTERCHANGE GUIDE



Solid Output Shaft-NEMA C Flange Reducer (Quill Input)										
CENTER DISTANCE (Inches)	1.75	2.06	2.38	2.62	3.00	3.25	3.75	4.25	5.25	6.00
HERA-ES drive w/plug-in shaft kit	HERA35ES	HERA35ES*	HERA35ES*			HERA55ES	HERA55ES*	HERA55ES*		
BALDOR**	F918	F921	F924	F926	F930	F932	F938	—	—	—
BOSTON**	F718	F721	F724	F726	F730	F732	F738	—	F752	F760
Dodge Tigear-2**	17Q	20Q	23Q	26Q	30Q	—	35Q	40Q	47Q	—
Falk® Omnibox**	1175WBM	1206WBM	1238WBM	1262WBM	1300WBM	1325WBM	—	1425WBM	1525WBM	1600WBM



Solid Output Shaft-NEMA C Flange Reducer (Coupled Input)										
CENTER DISTANCE (Inches)	1.75	2.06	2.38	2.62	3.00	3.25	3.75	4.25	5.25	6.00
HERA-PS drive w/plug-in shaft kit	HERA35PS	HERA35PS*	HERA35PS*			HERA55PS	HERA55PS*	HERA55PS*		
BALDOR**	LF918	LF921	LF924	LF926	LF930	LF932	LF938	—	—	—
BOSTON**	RF718	RF721	RF724	RF726	RF730	RF732	RF738	—	RF752	RF760
Dodge Tigear-2**	17A	20A	23A	26A	30A	—	35A	40A	47A	—
Falk Omnibox**	1175WBF	1206WBF	1238WBF	1262WBF	1300WBF	1325WBF	—	1425WBF	1525WBF	1600WBF



Solid Output Shaft-Non-Flanged Reducer (Basic Unit)										
CENTER DISTANCE (Inches)	1.75	2.06	2.38	2.62	3.00	3.25	3.75	4.25	5.25	6.00
HERA-AS drive w/plug-in shaft kit	HERA35AS	HERA35AS*	HERA35AS*			HERA55AS	HERA55AS*	HERA55AS*		
BALDOR**	S918	S921	S924	S926	S930	S932	S938	—	S952	S960
BOSTON**	718	721	724	726	730	732	738	—	752	760
Dodge Tigear-2**	17S	20S	23S	26S	30S	—	35S	40S	47S	—
Falk Omnibox**	1175WB	1206WB	1238WB	1262WB	1300WB	1325WB	—	1425WB	1525WB	1600WB

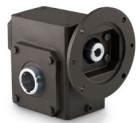

Hollow Output Shaft-NEMA C Flange Reducer (Quill Input)										
CENTER DISTANCE (Inches)	1.75	2.06	2.38	2.62	3.00	3.25	3.75	4.25	5.25	6.00
HERA-ES drive	HERA35ES	HERA35ES*	HERA35ES*			HERA55ES	HERA55ES*	HERA55ES*		
BALDOR**	HF918	HF921	HF924	HF926	HF930	HF932	HF938	—	—	—
BOSTON**	HF718	HF721	HF724	HF726	HF730	HF732	HF738	—	—	—
Dodge Tigear-2**	17QH	20QH	23QH	26QH	30QH	—	35QH	40QH	47QH	—
Falk Omnibox**	1175WBQM	1206WBQM	—	1262WBQM	1300WBQM	1325WBQM	—	1425WBQM	1525WBQM	1600WBQM



Hollow Output Shaft-NEMA C Flange Reducer (Coupled Input)										
CENTER DISTANCE (Inches)	1.75	2.06	2.38	2.62	3.00	3.25	3.75	4.25	5.25	6.00
HERA-PS drive	HERA35PS	HERA35PS*	HERA35PS*			HERA55PS	HERA55PS*	HERA55PS*		
BALDOR**	HLF918	HLF921	HLF924	HLF926	HLF930	HLF932	HLF938	—	—	—
BOSTON**	HRF718	HRF721	HRF724	HRF726	HRF730	HRF732	HRF738	—	—	—
Dodge Tigear-2**	17AH	20AH	23AH	26AH	30AH	—	35AH	40AH	47AH	—
Falk Omnibox**	1175WBQF	1206WBQF	—	1262WBQF	1300WBQF	1325WBQF	—	1425WBQF	1525WBQF	1600WBQF

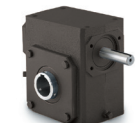

Hollow Output Shaft - Non-Flanged Reducer (Basic Unit)										
CENTER DISTANCE (Inches)	1.75	2.06	2.38	2.62	3.00	3.25	3.75	4.25	5.25	6.00
HERA-AS	HERA35AS	HERA35AS*	HERA35AS*			HERA55AS	HERA55AS*	HERA55AS*		
BALDOR**	HS918	HS921	HS924	HS926	HS930	HS932	HS938	—	—	—
BOSTON**	H718	H721	H724	H726	H730	H732	H738	—	—	—
Dodge Tigear-2**	17SH	20SH	23SH	26SH	30SH	—	35SH	40SH	47SH	—
Falk Omnibox**	1175WBQ	1206WBQ	1238WBQ	1262WBQ	1300WBQ	1325WBQ	—	1425WBQ	1525WBQ	1600WBQ

*B-Interchange base kit required for foot mounting (see accessory page 12).
 Information for reference only, consult factory at 605-225-0360 or hubsales@regalbeloit.com for information on your specific application.
 **The following trade names, trademarks and/or registered trademarks are used in this material by Regal Beloit Corporation for comparison purposes only, are NOT owned or controlled by Regal Beloit Corporation and are believed to be owned by the following parties. Baldor: ABB ASEA Brown Boveri Ltd.; Boston: Boston Gear LLC; Dodge and Tigear: Baldor Electric Company; Falk and Omnibox: Rexnord Industries, LLC

LOCATED TO SERVE YOU!

24-Hour assembly and shipment, and on-the-shelf availability of our most sought after HUB CITY™ products!

ABERDEEN CUSTOMER SERVICE AND MANUFACTURING

2914 Industrial Avenue
Aberdeen, SD 57401
(605) 225-0360
(800) 482-2489

FLORIDA ASSEMBLY DISTRIBUTION CENTER

4725 Lakeland Commerce Pkwy., Suite 6
Lakeland, FL 33805
(863) 665-9374

CALIFORNIA ASSEMBLY DISTRIBUTION CENTER

3505 E. Francis Street
Ontario, CA 91761
(909) 325-4052
(800) 551-6661

DALLAS ASSEMBLY DISTRIBUTION CENTER

3251 Royalty Row
Irving, TX 75062
(972) 721-0080
(800) 494-1918

INDIANAPOLIS ASSEMBLY DISTRIBUTION CENTER

9899 E. Bradford Road
Plainfield, IN 46168
(317) 856-4855
(800) 253-4281

ATLANTA ASSEMBLY DISTRIBUTION CENTER

135 Cecil Court
Fayetteville, GA 30214
(770) 461-8334
(800) 777-7159

CHARLOTTE ASSEMBLY DISTRIBUTION CENTER

1011 Van Buren Avenue
Indian Trail, NC 28079
(704) 847-9131

TORONTO ASSEMBLY DISTRIBUTION CENTER

80 Hale Road Unit #1
Brampton, Ontario L6W 3N9
(905) 455-6969
(888) 661-1889



Regal Beloit America, Inc.

2914 Industrial Avenue
Aberdeen, SD 57401
Customer Service: 800-482-2489
Fax: 605-225-0567
Technical Service: 605-225-0360
hubsales@regalbeloit.com

www.regalbeloit.com

APPLICATION CONSIDERATIONS

The proper selection and application of power transmission products and components, including the related area of product safety, is the responsibility of the customer. Operating and performance requirements and potential associated issues will vary appreciably depending upon the use and application of such products and components. The scope of the technical and application information included in this publication is necessarily limited. Unusual operating environments and conditions, lubrication requirements, loading supports, and other factors can materially affect the application and operating results of the products and components and the customer should carefully review its requirements. Any technical advice or review furnished by Regal Beloit America, Inc. and/or its affiliates ("Regal") with respect to the use of products and components is given in good faith and without charge, and Regal assumes no obligation or liability for the advice given, or results obtained, all such advice and review being given and accepted at customer's risk.

For a copy of our Standard Terms and Conditions of Sale, please visit <http://www.regalbeloit.com> (please see link at bottom of page to "Standard Terms and Conditions of Sale"). These terms and conditions of sale, disclaimers and limitations of liability apply to any person who may buy, acquire or use a Regal product referred to herein, including any person who buys from a licensed distributor of these branded products.

Regal, Marathon, HERA, HubCap and Hubloc are trademarks of Regal Beloit Corporation or one of its affiliated companies.

©2015, 2018 Regal Beloit Corporation, All Rights Reserved. MCB18068E • Form# 9928E

REGAL®