

Installation Manual for Bearing Take Up Frame Assemblies

These instructions must be read thoroughly before installation or operation.



INSTALLATION:

1. Make sure that Frame Number on bearing box corresponds with frame that is to be used.
2. Place take-up bearing in open end of frame with inner race facing outward, away from mounting surface. This allows easy locking of bearing to shaft and ample access to the lube fitting after installation.
3. Place adjusting screw thru hole in end of take-up frame and into bearing housing. Line up locking pin hole.
4. Support bearing housing and drive locking pin (packaged with bearing) into bearing housing and thru adjusting screw until pin is flush with housing. Install adjusting nut on other end of adjusting screw.
5. If possible, load should be parallel to take up screw.

WARNING Because of the possible danger to persons(s) or property from accidents which may result from the improper use of products, it is important that correct procedures be followed: Products must be used in accordance with the engineering information specified in the catalog. Proper installation, maintenance and operation procedures must be observed. The instructions in the instruction manuals must be followed. Inspections should be made as necessary to assure safe operation under prevailing conditions. Proper guards and other suitable safety devices or procedures as may be desirable or as may be specified in safety codes should be provided, and are neither provided by Baldor Electric Company nor are the responsibility of Baldor Electric Company. This unit and its associated equipment must be installed, adjusted and maintained by qualified personnel who are familiar with the construction and operation of all equipment in the system and the potential hazards involved. When risk to persons or property may be involved, a holding device must be an integral part of the driven equipment beyond the speed reducer output shaft.

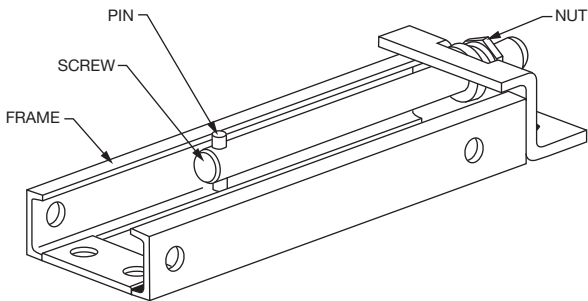

Table 1 - Bearing Take Up Frame Parts

Assembly Frame	Part Number			
	Frame	Screw	Nut	Pin
210 x 6	039109	130140	130141	409206
308 x 6	039110	406118	130141	409206
308 x 12	038111	406120	130141	409206
400 x 6	039112	406104	036153	409312
400 x 9	039113	406122	036153	409312
400 x 12	038114	406108	036153	409312
400 x 18	038115	406124	036153	409312
407 x 9	039116	130149	036154	409054
407 x 18	039117	130150	036154	409054
415 x 9	039118	130149	036154	409054
415 x 18	039119	130150	036154	409054



BALDOR

A MEMBER OF THE ABB GROUP

P.O. Box 2400, Fort Smith, AR 72902-2400 U.S.A., Ph: (1) 479.646.4711, Fax (1) 479.648.5792, International Fax (1) 479.648.5895

Dodge Product Support

6040 Ponders Court, Greenville, SC 29615-4617 U.S.A., Ph: (1) 864.297.4800, Fax: (1) 864.281.2433

www.baldor.com