

# Maximum Rating Tables

Size 815 • GR, NH Series



Style B

Style H

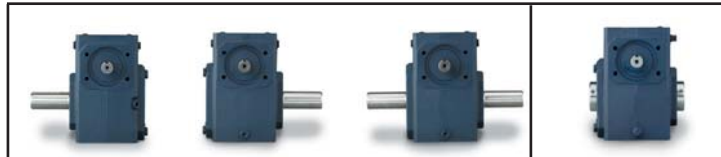

## Size 815

Ratio	Input RPM	Output RPM	Input HP	Output HP	Output Torque (lb-in)	Left Hand Catalog No.	Right Hand Catalog No.	Double Extension Catalog No.	Hollow Output Catalog No.*
<b>5</b>	2500	500	2.310	2.151	271	_8150001	_8150013	_8150025	_8150501.10
	1750	350	1.939	1.794	323				
	1170	234	1.537	1.408	379				
<b>7.5</b>	100	20	0.235	0.167	526	_8150002	_8150014	_8150026	_8150502.10
	2500	333	1.785	1.619	306				
	1170	156	1.205	1.068	431				
<b>10</b>	100	13	0.196	0.125	591	_8150003	_8150015	_8150027	_8150503.10
	2500	250	1.500	1.324	334				
	1170	117	1.014	0.869	468				
<b>15</b>	100	10	0.176	0.101	639	_8150004	_8150016	_8150028	_8150504.10
	2500	166	1.174	0.982	371				
	1170	116	1.003	0.826	446				
<b>20</b>	100	6.7	0.155	0.075	706	_8150005	_8150017	_8150029	_8150505.10
	2500	125	1.077	0.860	434				
	1170	87	0.919	0.719	518				
<b>25</b>	100	5.0	0.155	0.064	807	_8150006	_8150018	_8150030	_8150506.10
	2500	100	0.881	0.670	422				
	1170	70	0.752	0.559	503				
<b>30</b>	100	4.0	0.137	0.049	775	_8150007	_8150019	_8150031	_8150507.10
	2500	83	0.729	0.526	398				
	1170	46	0.602	0.431	580				
<b>40</b>	100	3.3	0.124	0.040	754	_8150008	_8150020	_8150032	_8150508.10
	2500	62	0.649	0.432	435				
	1170	29	0.456	0.279	601				
<b>50</b>	100	2.5	0.122	0.032	808	_8150009	_8150021	_8150033	_8150509.10
	2500	50	0.536	0.329	415				
	1170	23	0.379	0.211	569				
<b>60</b>	100	2.0	0.110	0.024	760	_8150010	_8150022	_8150034	_8150510.10
	2500	41	0.451	0.257	389				
	1170	19	0.321	0.165	532				
<b>80</b>	100	1.7	0.099	0.019	707	_8150011	_8150023	_8150035	_8150511.10
	2500	31	0.219	0.109	220				
	1170	14	0.176	0.073	314				
<b>100</b>	100	1.3	0.032	0.008	418	_8150012	_8150024	_8150036	_8150512.10
	2500	25	0.155	0.069	175				
	1170	11	0.126	0.046	248				
	100	1.0	0.024	0.005	328				

### How To Build a Part Number For Size GR815 & NH815

1. Select partial catalog number from the selection table
2. Replace leading “\_” with series code (GR, NH)

**Example:**

Grove Gear IRONMAN, style B, 5:1 ratio, left hand output  
 GR-B815-5-L  
 GR8150001

Single Reduction  
Worm Gear Reducers









Double Reduction  
Worm - Worm Gear Reducers

Double Reduction  
Helical - Worm Gear Reducers

WASHGUARD® Reducers  
and GEAR+MOTOR™

Ratio Multipliers

Accessories and  
Additional Capabilities

	Style BM			Style HM	Style BMQ			Style HMQ	
									
NEMA C Input Flange ▲	Left Hand Catalog No.	Right Hand Catalog No.	Double Extension Catalog No.	Hollow Output Catalog No.	Left Hand Catalog No.	Right Hand Catalog No.	Double Extension Catalog No.	Hollow Output Catalog No.	Ratio
56C 143-5TC	<u>8150073</u> <u>8150109</u>	<u>8150085</u> <u>8150121</u>	<u>8150097</u> <u>8150133</u>	<u>8150525.10</u> <u>8150537.10</u>	<u>8150181</u> <u>8150217</u>	<u>8150193</u> <u>8150229</u>	<u>8150205</u> <u>8150241</u>	<u>8150561.10</u> <u>8150573.10</u>	<b>5</b>
56C 143-5TC	<u>8150074</u> <u>8150110</u>	<u>8150086</u> <u>8150122</u>	<u>8150098</u> <u>8150134</u>	<u>8150526.10</u> <u>8150538.10</u>	<u>8150182</u> <u>8150218</u>	<u>8150194</u> <u>8150230</u>	<u>8150206</u> <u>8150242</u>	<u>8150562.10</u> <u>8150574.10</u>	<b>7.5</b>
56C 143-5TC	<u>8150075</u> <u>8150111</u>	<u>8150087</u> <u>8150123</u>	<u>8150099</u> <u>8150135</u>	<u>8150527.10</u> <u>8150539.10</u>	<u>8150183</u> <u>8150219</u>	<u>8150195</u> <u>8150231</u>	<u>8150207</u> <u>8150243</u>	<u>8150563.10</u> <u>8150575.10</u>	<b>10</b>
56C 143-5TC	<u>8150076</u> <u>8150112</u>	<u>8150088</u> <u>8150124</u>	<u>8150100</u> <u>8150136</u>	<u>8150528.10</u> <u>8150540.10</u>	<u>8150184</u> <u>8150220</u>	<u>8150196</u> <u>8150232</u>	<u>8150208</u> <u>8150244</u>	<u>8150564.10</u> <u>8150576.10</u>	<b>15</b>
56C 143-5TC	<u>8150077</u> <u>8150113</u>	<u>8150089</u> <u>8150125</u>	<u>8150101</u> <u>8150137</u>	<u>8150529.10</u> <u>8150541.10</u>	<u>8150185</u> <u>8150221</u>	<u>8150197</u> <u>8150233</u>	<u>8150209</u> <u>8150245</u>	<u>8150565.10</u> <u>8150577.10</u>	<b>20</b>
56C	<u>8150078</u>	<u>8150090</u>	<u>8150102</u>	<u>8150530.10</u>	<u>8150186</u>	<u>8150198</u>	<u>8150210</u>	<u>8150566.10</u>	<b>25</b>
48CZ 56C	<u>8150043</u> <u>8150079</u>	<u>8150055</u> <u>8150091</u>	<u>8150067</u> <u>8150103</u>	<u>8150519.10</u> <u>8150531.10</u>	<u>8150151</u> <u>8150187</u>	<u>8150163</u> <u>8150199</u>	<u>8150175</u> <u>8150211</u>	<u>8150555.10</u> <u>8150567.10</u>	<b>30</b>
48CZ 56C	<u>8150044</u> <u>8150080</u>	<u>8150056</u> <u>8150092</u>	<u>8150068</u> <u>8150104</u>	<u>8150520.10</u> <u>8150532.10</u>	<u>8150152</u> <u>8150188</u>	<u>8150164</u> <u>8150200</u>	<u>8150176</u> <u>8150212</u>	<u>8150556.10</u> <u>8150568.10</u>	<b>40</b>
48CZ 56C	<u>8150045</u> <u>8150081</u>	<u>8150057</u> <u>8150093</u>	<u>8150069</u> <u>8150105</u>	<u>8150521.10</u> <u>8150533.10</u>	<u>8150153</u> <u>8150189</u>	<u>8150165</u> <u>8150201</u>	<u>8150177</u> <u>8150213</u>	<u>8150557.10</u> <u>8150569.10</u>	<b>50</b>
48CZ 56C	<u>8150046</u> <u>8150082</u>	<u>8150058</u> <u>8150094</u>	<u>8150070</u> <u>8150106</u>	<u>8150522.10</u> <u>8150534.10</u>	<u>8150154</u> <u>8150190</u>	<u>8150166</u> <u>8150202</u>	<u>8150178</u> <u>8150214</u>	<u>8150558.10</u> <u>8150570.10</u>	<b>60</b>
48CZ 56C	<u>8150047</u> <u>8150083</u>	<u>8150059</u> <u>8150095</u>	<u>8150071</u> <u>8150107</u>	<u>8150523.10</u> <u>8150535.10</u>	<u>8150155</u> <u>8150191</u>	<u>8150167</u> <u>8150203</u>	<u>8150179</u> <u>8150215</u>	<u>8150559.10</u> <u>8150571.10</u>	<b>80</b>
48CZ 56C	<u>8150048</u> <u>8150084</u>	<u>8150060</u> <u>8150096</u>	<u>8150072</u> <u>8150108</u>	<u>8150524.10</u> <u>8150536.10</u>	<u>8150156</u> <u>8150192</u>	<u>8150168</u> <u>8150204</u>	<u>8150180</u> <u>8150216</u>	<u>8150560.10</u> <u>8150572.10</u>	<b>100</b>

For input/ output shaft overhung load and thrust load ratings, refer to pages 419-422.

▲ Consult Factory for other motor flanges available.



# GR Series Dimensions

Styles: HMQ, HM, H

**CAST IRON**  
**GR SERIES**

Single Reduction  
Worm Gear Reducers

Double Reduction  
Worm - Worm Gear Reducers

Double Reduction  
Helical - Worm Gear Reducers

WASHGUARD® Reducers  
and GEAR+MOTOR™

Ratio Multipliers

Accessories and  
Additional Capabilities

## Style HMQ

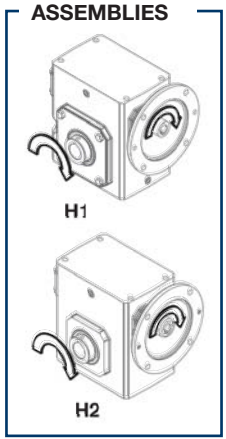
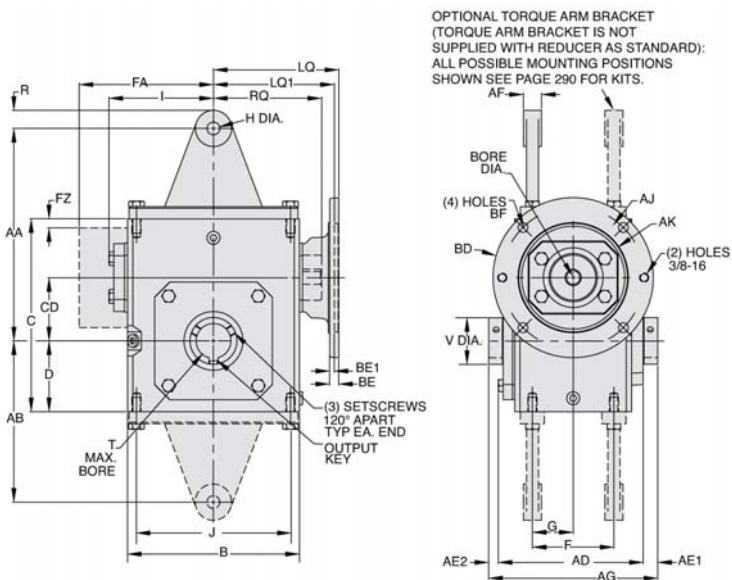

H1 SUPPLIED AS STANDARD UNLESS SPECIFIED.

## Style HM

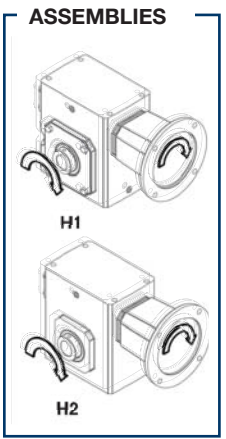
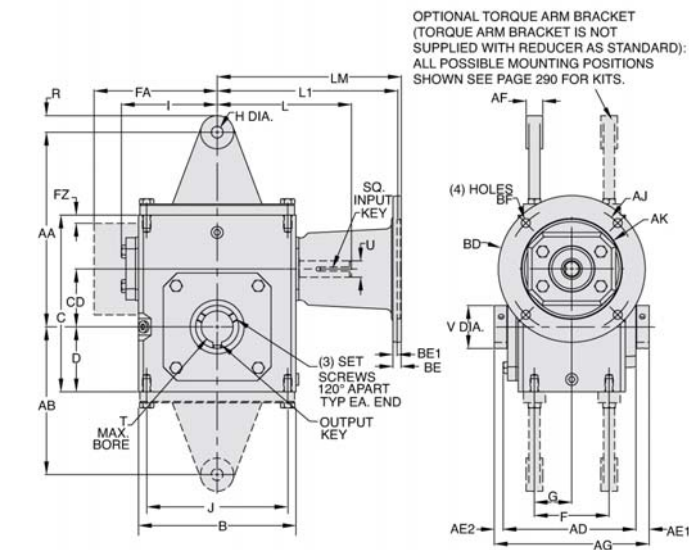

H1 SUPPLIED AS STANDARD UNLESS SPECIFIED.

## Style H

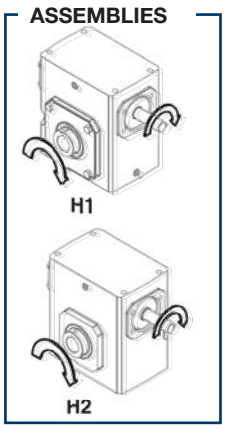
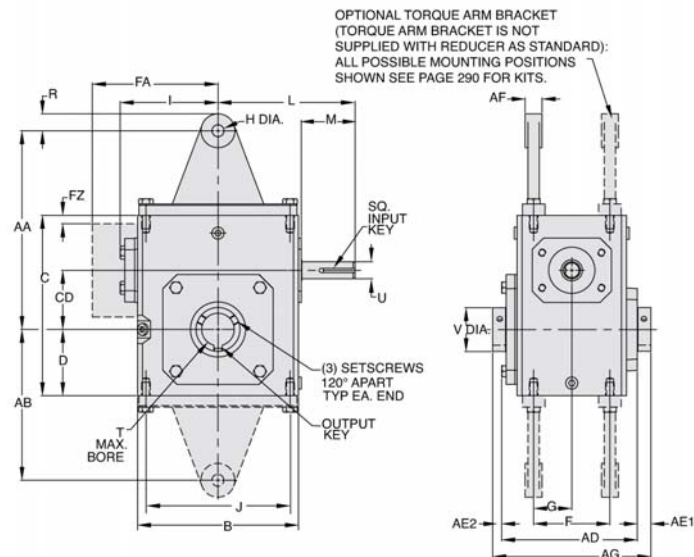

REVERSE ALL ARROWS FOR OPPOSITE INPUT SHAFT ROTATION. CONTACT FACTORY FOR OTHER MOUNTINGS OR ASSEMBLY POSITIONS.

H1 SUPPLIED AS STANDARD UNLESS SPECIFIED.



**STYLE HMQ, HM, H DIMENSIONS (Inches)**

Series	AD	AE1	AE2	AG	B	C	D	CD	F	FA▼	FZ▼	G	I	J	L	M	V	T MAX -0.000 +0.0025	U +0.000 -0.0015	Input Key*	Output Key +
GR813	3.90	0.53	0.32	4.75	3.80	4.66	1.72	1.33	2.00	N/A	N/A	1.00	2.61	3.25	3.82	1.76	1.000	0.625	0.500	1/8 x 1.00	3/16 x 1.50
GR815	4.61	0.51	0.30	5.42	5.19	5.38	1.91	1.54	2.75	N/A	N/A	1.38	3.14	4.19	4.35	1.76	1.000	0.625	0.625	3/16 x 1.38	3/16 x 1.50
GR818	4.73	0.49	0.28	5.50	5.19	5.75	2.06	1.75	2.75	N/A	N/A	1.38	3.24	4.19	4.45	1.76	1.440	1.000	0.625	3/16 x 1.38	1/4 x 3.00
GR821	4.99	0.61	0.40	6.00	5.80	6.38	2.28	2.06	▲	N/A	N/A	1.44	3.61	▲	4.82	1.76	1.940	1.500	0.625	3/16 x 1.38	3/8 x 3.00
GR824	5.18	0.51	0.31	6.00	6.12	6.94	2.50	2.38	2.88	N/A	N/A	1.44	3.77	5.00	5.51	2.38	1.940	1.500	0.750	3/16 x 1.63	3/8 x 3.00
GR826x	6.01	0.60	0.39	7.00	7.38	8.00	2.94	2.63	3.38	N/A	N/A	1.69	4.34	6.38	6.07	2.38	1.940	1.500	0.750	3/16 x 1.63	3/8 x 3.00
GR830	6.53	0.60	0.36	7.50	8.12	8.88	3.25	3.00	4.00	N/A	N/A	2.00	4.84	7.00	6.57	2.38	2.756	2.188	0.875	3/16 x 1.63	1/2 x 3.00
GR832x	7.04	0.54	0.29	7.88	8.75	9.38	3.50	3.25	4.00	N/A	N/A	2.00	5.02	7.50	6.76	2.38	2.756	2.188	0.875	3/16 x 1.63	1/2 x 3.00
GR842	7.53	0.63	0.34	8.50	10.25	11.38	4.44	4.25	5.00	N/A	N/A	2.50	6.10	8.50	9.57	3.47	2.756	2.188	1.250	1/4 x 2.50	1/2 x 3.00
GR852	8.85	0.97	0.68	10.50	13.00	14.00	5.12	5.25	5.81	N/A	N/A	2.91	7.50	11.00	10.88	3.38	4.260	3.438	1.250	1/4 x3.00	7/8 x3.44
GR860	10.52	0.52	0.52	11.50	14.50	16.50	6.50	6.00	6.38	11.13	0.33	3.19	N/A	12.75	11.78	3.41	4.256	3.438	1.500	3/8 x 3.00	7/8 x 3.44
GR870	11.36	1.09	1.09	13.50	14.88	18.91	7.59	7.00	5.50	11.37	0.35	2.75	N/A	12.50	11.50	2.97	4.928	3.938	1.625	3/8 x 2.87**	1 x 1/2**
GR880	12.48	1.03	1.03	14.50	17.00	20.96	8.86	8.00	6.50	12.52	0.57	3.25	N/A	14.25	12.50	2.84	5.553	4.438	1.875	1/2 x 2.81**	1 x 1/2**
GR8100	15.78	1.39	1.39	18.50	20.88	25.47	10.36	10.00	6.88	14.69	0.51	3.44	N/A	14.75	15.50	3.76	4.256	5.438	2.250	1/2 x 3.69**	1-1/4 x 5/8**

▲ See feature comparison chart.

**FEATURE COMPARISON (821)**

Size	Output Shaft Diameter Needed?	Mounting Footprint Needed?	Output Key Needed?	All Other Features	Grove Gear Flexaline Interchange	LEESON IRONMAN Interchange	Replace With Series Code Below:
GR821	Identical	(F)3.00" x (J)4.75"	Identical	Identical	✓	✓	GRG
		(F)2.88" x (J)5.00"					GRL

NOTE: If reducer is used without the accessory mounted, select based mounting dimensions on pages 52-53 (B, BM, BMQ).

**Motor Mounting Dimensions**  
**NEMA DIMENSIONS (Inches)**

Size	48CZ	LM	56C/140TC	180TC/210TC	L1	250TC	LQ	48CZ/56C/140TC	180TC	LQ1	210TC	250TC	48CZ/56C/140TC	180TC	RQ	210TC	250TC
GR813	5.63	6.07	N/A	N/A	N/A	N/A	3.46	N/A	N/A	N/A	N/A	N/A	3.09	N/A	N/A	N/A	N/A
GR815	6.16	6.60	N/A	N/A	N/A	N/A	3.99	N/A	N/A	N/A	N/A	N/A	3.62	N/A	N/A	N/A	N/A
GR818	6.26	6.70	N/A	N/A	N/A	N/A	4.09	N/A	N/A	N/A	N/A	N/A	3.59	N/A	N/A	N/A	N/A
GR821*	6.63	7.07	N/A	N/A	N/A	N/A	4.46	N/A	N/A	N/A	N/A	N/A	4.06	N/A	N/A	N/A	N/A
GR824	N/A	7.76	8.76	N/A	4.63	5.06	N/A	N/A	4.09	4.56	N/A	N/A	N/A	N/A	N/A	N/A	N/A
GR826*	N/A	8.32	9.32	N/A	5.19	5.62	N/A	N/A	4.82	5.13	N/A	N/A	N/A	N/A	N/A	N/A	N/A
GR830	N/A	8.82	9.82	N/A	5.95	6.15	6.56	N/A	5.32	5.63	6.06	N/A	N/A	N/A	N/A	N/A	N/A
GR832*	N/A	9.01	10.01	N/A	6.14	6.34	6.75	N/A	5.51	5.81	6.25	N/A	N/A	N/A	N/A	N/A	N/A
GR842	N/A	11.81	12.90	13.46	6.45	7.21	7.21	7.77	6.04	6.68	6.68	7.24	N/A	N/A	N/A	N/A	N/A
GR852	N/A	13.21	14.30	14.86	7.85	8.61	8.61	9.17	7.35	7.98	7.98	8.54	N/A	N/A	N/A	N/A	N/A
GR860	N/A	N/A	15.88	16.50	10.45	9.33	9.33	9.94	10.01	8.69	8.69	8.69	N/A	N/A	N/A	N/A	N/A
GR870	N/A	N/A	15.50	15.50	N/A	N/A	N/A	N/A	N/A	N/A	N/A	N/A	N/A	N/A	N/A	N/A	N/A
GR880	N/A	N/A	16.58	16.58	N/A	N/A	N/A	N/A	N/A	N/A	N/A	N/A	N/A	N/A	N/A	N/A	N/A

**NEMA DIMENSIONS (Inches)**

Frame	AjB	AK	BD	BE	BE1	Bore Dia.	Keyway♦	BFb
	3.75	3.00	4.36	0.38	N/A	.500	1/8 X 1/16	0.28
56C	5.88	4.50	6.50	0.38	N/A	.625	3/16 X 3/32	0.41
140TC	5.88	4.50	6.50	0.38	N/A	.875	3/16 X 3/32	0.41
180TC	7.25	8.50	9.00	N/A	0.50	1.125	1/4 X 1/8	0.53
210TC	7.25	8.50	9.00	N/A	0.50	1.375	5/16 X 5/32	0.53
250TC	7.25	8.50	9.00	N/A	0.50	1.625	3/8 X 3/16	0.53

**IEC B5 & B3/B5 METRIC DIMENSIONS (Inches)\***

Size	LQ1						RQ					
	D63D	D71D	D80D	D90D	D100LD/D112MD	D132D	D63D	D71D	D80D	D90D	D100LD/D112MD	D132D
GR813	2.62	2.65	2.89	N/A	N/A	N/A	2.45	2.47	2.71	N/A	N/A	N/A
GR815	3.15	3.18	3.42	N/A	N/A	N/A	2.98	3.00	3.24	N/A	N/A	N/A
GR818	3.25	3.28	3.52	N/A	N/A	N/A	2.95	2.97	3.21	N/A	N/A	N/A
GR821*	3.62	3.65	3.89	N/A	N/A	N/A	3.43	3.44	3.68	N/A	N/A	N/A
GR824	N/A	3.72	4.34	N/A	N/A	N/A	3.46	3.71	N/A	N/A	N/A	N/A
GR826*	N/A	4.28	4.90	4.90	5.30	N/A	N/A	4.09	4.72	4.72	5.07	N/A
GR830	N/A	4.78	5.41	5.41	5.88	N/A	N/A	4.59	5.22	5.22	5.57	N/A
GR832*	N/A	4.97	5.59	5.59	6.07	N/A	N/A	4.78	5.41	5.41	5.76	N/A
GR842	N/A	N/A	N/A	6.38	6.39	7.17	N/A	N/A	N/A	6.16	6.14	6.93
GR852	N/A	N/A	N/A	7.78	7.78	8.57	N/A	N/A	N/A	7.46	7.45	8.24

**IEC B5 & B3/B5 METRIC DIMENSIONS (MM)**

Frame	AJ	AK	BD	BE	Bore Dia.	Keyway♦	BF TAP	OD
D63D	115	95	117	10	11	4 X 2	M8 X 1.25	131
D71D	130	110	132	11	14	5 X 2.5	M8 X 1.25	146
D80D	165	130	165	15	19	6 X 3	M10 X 1.50	184
D90D	165	130	165	15	24	8 X 3.5	M10 X 1.50	184
D100LD/D112MD	215	180	216	18	28	8 X 3.5	M12 X 1.75	237
D132D	265	230	267	18	38	10 X 4	M12 X 1.75	290

\* Max bore dimensions shown. For additional bores available, refer to page 20.

\* Applies to double output shaft

\*\* Key not provided with gear reducer. Keyway dimension shown.

♦ Keyway width by depth

⊙ Mounting holes rotated 45 degrees from positions shown on Size GR860, Style HM with frame sizes 180TC-250TC.

■ 48CZ not available

● 180TC not available

⊕ Metric IEC B5 input flange options are available only on quill input styles.

\* Dimensions same for GRG and GRL Series

\* Style H and HM only.

▼ Sizes 860-8100 are supplied with a fan. Dimensions refer to fan guard location.

Note: Torque arm bracket available separately. Refer to page 274 for kits. If a special bracket is required, refer to Style BMQ dimensions for mounting pad dimensions on top/bottom of reducer.



For safety, purchaser or user should provide protective guards over shaft extensions and any couplings, sheaves and belts, sprockets and chains, etc., mounted thereon.

Single Reduction  
Worm Gear Reducers

Double Reduction  
Worm - Worm Gear Reducers

Double Reduction  
Helical - Worm Gear Reducers

WASHGARD® Reducers  
and GEAR-HMOTOR™

Ratio Multipliers

Accessories and  
Additional Capabilities