

Maximum Rating Tables

Size 832 • GR & EL Series



Style B

Style H

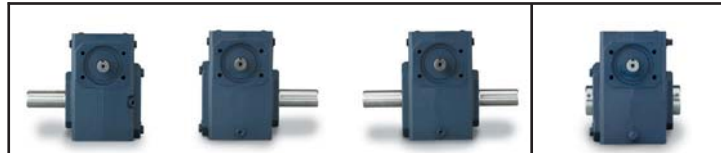

Size 832

Ratio	Input RPM	Output RPM	Input HP	Output HP	Output Torque (lb-in)	Left Hand Catalog No.	Right Hand Catalog No.	Double Extension Catalog No.	Hollow Output Catalog No.*
5	2500	500	13.94	13.24	1669	8320097	8320101	8320105	8320557.XX
	1750	350	11.92	11.29	2033				
	1170	234	9.790	9.220	2483				
	100	20	1.567	1.267	3994				
7.5	2500	333	10.36	9.695	1833	8320098	8320102	8320106	8320558.XX
	1750	233	8.863	8.264	2232				
	1170	156	7.286	6.747	2726				
	100	13	1.201	0.926	4375				
10	2500	250	9.601	8.943	2254	8320001	8320009	8320017	8320501.XX
	1750	175	8.092	7.497	2700				
	1170	117	6.604	6.066	3268				
	100	10	1.048	0.770	4853				
15	2500	166	7.258	6.582	2489	8320002	8320010	8320018	8320502.XX
	1750	116	6.127	5.516	2980				
	1170	78	5.031	4.478	3618				
	100	6.7	0.853	0.573	5413				
20	2500	125	6.122	5.412	2729	8320003	8320011	8320019	8320503.XX
	1750	87	5.180	4.536	3267				
	1170	58	4.215	3.636	3917				
	100	5.0	0.746	0.452	5695				
25	2500	100	5.162	4.457	2809	8320004	8320012	8320020	8320504.XX
	1750	70	4.373	3.732	3360				
	1170	46	3.543	2.968	3996				
	100	4.0	0.655	0.362	5710				
30	2500	83	4.262	3.562	2694	8320005	8320013	8320021	8320505.XX
	1750	58	3.619	2.986	3226				
	1170	39	2.987	2.415	3902				
	100	3.3	0.593	0.306	5787				
40	2500	62	3.434	2.736	2759	8320006	8320014	8320022	8320506.XX
	1750	43	2.926	2.293	3303				
	1170	29	2.402	1.833	3950				
	100	2.5	0.513	0.227	5710				
50	2500	50	2.883	2.199	2772	8320007	8320015	8320023	8320507.XX
	1750	35	2.462	1.841	3315				
	1170	23	2.018	1.461	3935				
	100	2.0	0.458	0.178	5601				
60	2500	41	2.471	1.812	2741	8320008	8320016	8320024	8320508.XX
	1750	29	2.114	1.515	3274				
	1170	19	1.733	1.197	3869				
	100	1.7	0.414	0.144	5448				
80	2500	31	1.122	0.796	1605	8320099	8320103	8320107	8320559.XX
	1750	21	1.030	0.695	2000				
	1170	14	0.869	0.551	2371				
	100	1.3	0.143	0.064	3246				
100	2500	25	0.754	0.503	1268	8320100	8320104	8320108	8320560.XX
	1750	17	0.691	0.435	1567				
	1170	11	0.584	0.343	1846				
	100	1.0	0.097	0.040	2496				

How To Build a Part Number For Size GR832, GRG832, GRL832, EL832

1. Select partial catalog number from the selection table
2. Replace leading “_” with series code (GR, GRG, GRL, EL) (see next page for codes)
3. For hollow output, replace “XX” suffix with bore code

Example:

Grove Gear IRONMAN, hollow output shaft, 5:1 ratio, 180TC coupling input
 GR-HM832-5-H-180TC-19
 GR8320569.19









GRG = GROVE GEAR

- Direct replacement to Grove Gear Flexaline
- 1-1/2" solid output shaft diameter
- For hollow bores, specify GRL Interchange
- Solid output shaft only

GRL = IRONMAN Interchange



- Direct replacement to LEESON IRONMAN & major brands.
- Hollow shaft option available
- 1-3/8" solid output shaft diameter

	Style BM			Style HM	Style BMQ			Style HMQ	
									
NEMA C Input Flange▲	Left Hand Catalog No.	Right Hand Catalog No.	Double Extension Catalog No.	Hollow Output Catalog No.*	Left Hand Catalog No.	Right Hand Catalog No.	Double Extension Catalog No.	Hollow Output Catalog No.*	Ratio
182-4TC 213-5TC	8320205 8320217	8320209 8320229	8320213 8320241	8320569.XX 8320573.XX	8320277 8320289	8320281 8320301	8320285 8320313	8320593.XX 8320597.XX	5
182-4TC 213-5TC	8320206 8320218	8320210 8320230	8320214 8320242	8320570.XX 8320574.XX	8320278 8320290	8320282 8320302	8320286 8320314	8320594.XX 8320598.XX	7.5
143-5TC 182-4TC 213-5TC	8320049 8320073 8320219	8320057 8320081 8320231	8320065 8320089 8320243	8320517.XX 8320525.XX 8320575.XX	8320145 8320169 8320291	8320153 8320177 8320303	8320161 8320185 8320315	8320541.XX 8320549.XX 8320599.XX	10
143-5TC 182-4TC	8320050 8320074	8320058 8320082	8320066 8320090	8320518.XX 8320526.XX	8320146 8320170	8320154 8320178	8320162 8320186	8320542.XX 8320550.XX	15
143-5TC 182-4TC	8320051 8320075	8320059 8320083	8320067 8320091	8320519.XX 8320527.XX	8320147 8320171	8320155 8320179	8320163 8320187	8320543.XX 8320551.XX	20
143-5TC 182-4TC	8320052 8320076	8320060 8320084	8320068 8320092	8320520.XX 8320528.XX	8320148 8320172	8320156 8320180	8320164 8320188	8320544.XX 8320552.XX	25
143-5TC 182-4TC	8320053 8320077	8320061 8320085	8320069 8320093	8320521.XX 8320529.XX	8320149 8320173	8320157 8320181	8320165 8320189	8320545.XX 8320553.XX	30
56C 143-5TC 182-4TC	8320030 8320054 8320078	8320038 8320062 8320086	8320046 8320070 8320094	8320514.XX 8320522.XX 8320530.XX	8320126 8320150 8320174	8320134 8320158 8320182	8320142 8320166 8320190	8320538.XX 8320546.XX 8320554.XX	40
56C 143-5TC 182-4TC	8320031 8320055 8320079	8320039 8320063 8320087	8320047 8320071 8320095	8320515.XX 8320523.XX 8320531.XX	8320127 8320151 8320175	8320135 8320159 8320183	8320143 8320167 8320191	8320539.XX 8320547.XX 8320555.XX	50
56C 143-5TC 182-4TC	8320032 8320056 8320080	8320040 8320064 8320088	8320048 8320072 8320096	8320516.XX 8320524.XX 8320532.XX	8320128 8320152 8320176	8320136 8320160 8320184	8320144 8320168 8320192	8320540.XX 8320548.XX 8320556.XX	60
56C 143-5TC	8320111 8320195	8320115 8320199	8320119 8320203	8320563.XX 8320567.XX	8320255 8320267	8320259 8320271	8320263 8320275	8320587.XX 8320591.XX	80
56C	8320112	8320116	8320120	8320564.XX	8320256	8320260	8320264	8320588.XX	100

For input/ output shaft overhung load and thrust load ratings, refer to pages 419-422.

▲ Consult Factory for other motor flanges available.
* Catalog numbers are for hollow output shaft reducers.
When ordering, substitute the XX suffix with the required output bore code.

Available bore codes

Fraction Size	1-3/16"	1-1/4"	1-7/16"	1-1/2"	1-5/8"	1-11/16"	1-3/4"	1-7/8"	1-15/16"	2"	2-3/16"
Decimal Size	1.188	1.250	1.438	1.500	1.625	1.688	1.750	1.875	1.938	2.000	2.188
Output Bore Code	19	20	23	24	26	27	28	30	31	32	35

Single Reduction
Worm Gear Reducers

Double Reduction
Worm - Worm Gear Reducers

Double Reduction
Helical - Worm Gear Reducers

WASHGUARD® Reducers
and GEAR+MOTOR™

Ratio Multipliers

Accessories and
Additional Capabilities



GR Series Dimensions

Styles: FMQ, FM, F

CAST IRON
GR SERIES

Style FMQ

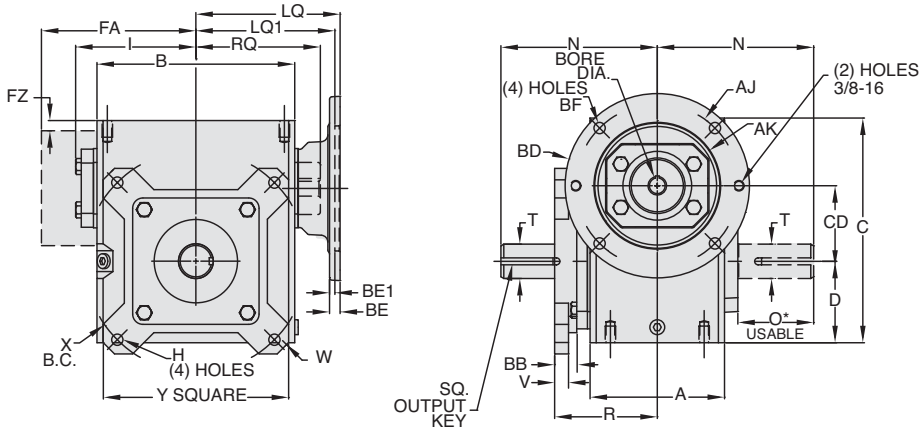

Style FM

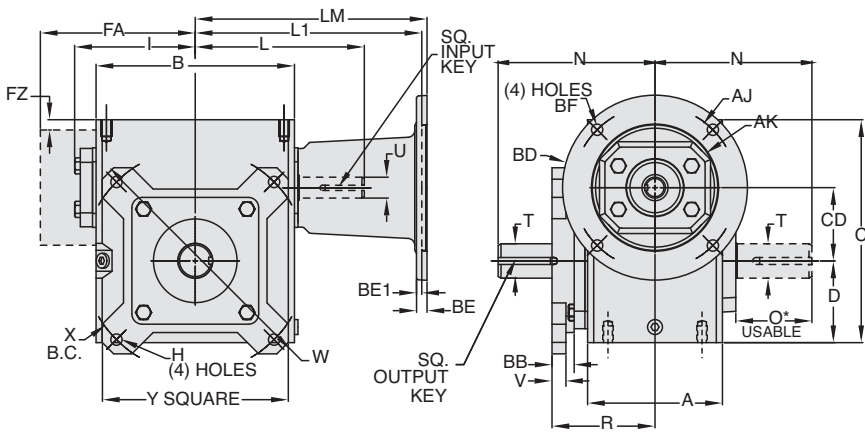

Style F

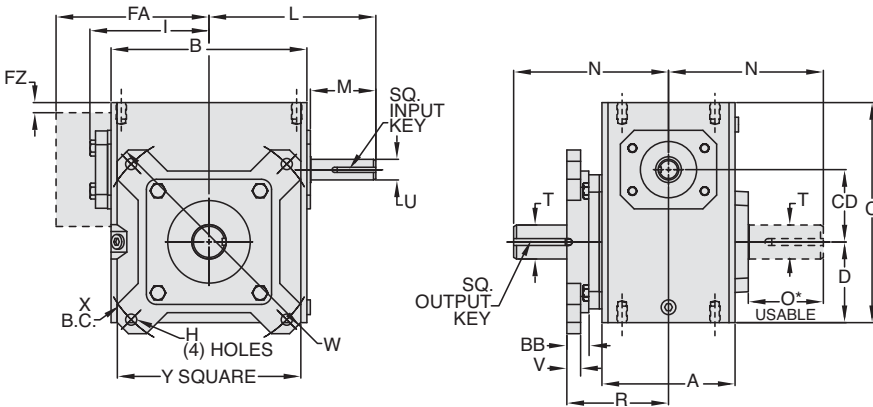

Sizes 813-8100 output flange must be mounted at Factory on styles FMQ, FM, F.

ASSEMBLIES

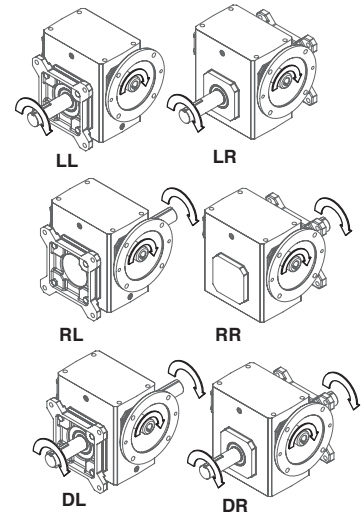

ASSEMBLIES

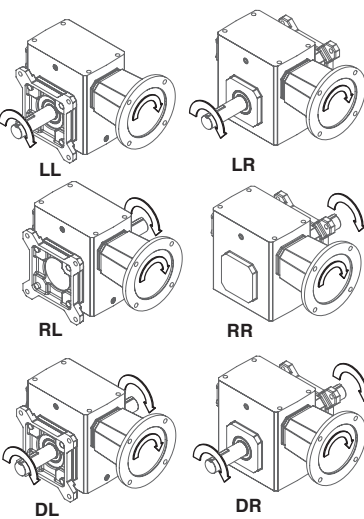

ASSEMBLIES

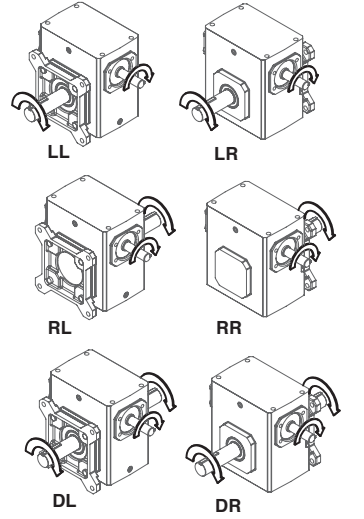

REVERSE ALL ARROWS FOR OPPOSITE INPUT SHAFT ROTATION. CONTACT FACTORY FOR OTHER MOUNTINGS OR ASSEMBLY POSITIONS.

Single Reduction
Worm Gear Reducers

Double Reduction
Worm - Worm Gear Reducers

Double Reduction
Helical - Worm Gear Reducers

WASHGUARD® Reducers
and GEAR+MOTOR™

Ratio Multipliers

Accessories and
Additional Capabilities



GR Series Dimensions

Styles: FMQ, FM, F



STYLE FMQ, FM, F DIMENSIONS (Inches)

Series	A	B	BB	C	D	CD	FA▼	FZ▼	H	I	L	M	N	O	R	V	W	X	Y	T MAX+ -0.000 +0.0025	U -0.000 -0.0015	Input Key*	Output Key
GR813	2.82	3.80	0.675	4.66	1.72	1.33	N/A	N/A	0.03	2.61	3.82	1.76	4.00	1.94	2.52	0.38	5.92	5.00	4.50	0.625	0.500	1/8 x 1.00	3/16 x 1.50
GR815	3.44	4.88	0.675	5.38	1.91	1.54	N/A	N/A	0.03	3.14	4.35	1.76	4.31	1.90	2.87	0.38	5.88	5.00	4.50	0.750	0.625	3/16 x 1.38	3/16 x 1.50
GR818	3.56	5.06	0.925	5.75	2.06	1.75	N/A	N/A	0.03	3.24	4.45	1.76	4.31	1.84	3.18	0.38	6.64	5.88	5.00	0.875	0.625	3/16 x 1.38	3/16 x 1.38
GR821	3.81	5.80	1.24	6.38	2.28	2.06	N/A	N/A	0.41	3.61	4.82	1.76	4.68	2.08	3.69	0.44	7.88	7.00	5.99	1.000	0.625	3/16 x 1.38	1/4 x 1.44
GR824	4.06	6.12	1.560	6.94	2.50	2.38	N/A	N/A	0.41	3.77	5.51	2.38	5.14	2.44	3.73	0.44	8.39	7.50	6.27	1.125	0.750	3/16 x 1.63	1/4 x 1.75
GR826	4.84	7.12	0.796	8.00	2.94	2.63	N/A	N/A	0.41	4.34	6.07	2.38	5.63	2.52	3.70	0.50	8.88	8.00	6.67	▲	0.750	3/16 x 1.63	1/4 x 1.75
GR830	5.25	8.12	0.636	8.88	3.25	3.00	N/A	N/A	0.41	4.84	6.57	2.38	6.75	3.36	3.78	0.50	9.89	9.00	7.37	1.250	0.875	3/16 x 1.63	1/4 x 1.75
GR832	5.75	8.50	0.636	9.38	3.50	3.25	N/A	N/A	0.41	5.02	6.76	2.38	7.06	3.42	4.03	0.50	9.89	9.00	7.37	▲	0.875	3/16 x 1.63	3/8 x 2.25
GR842	6.13	10.25	0.940	11.38	4.44	4.25	N/A	N/A	0.56	6.10	9.57	3.47	8.12	4.21	4.56	0.62	12.95	11.50	9.65	1.875	1.250	1/4 x 2.50	1/2 x 3.06
GR852	7.19	13.00	1.340	14.00	5.12	5.25	N/A	N/A	0.69	7.50	10.88	3.38	9.16	4.53	5.62	0.75	15.50	14.00	11.75	2.000	1.250	1/4 x 3.00	1/2 x 3.50
GR860	8.13	14.25	2.603	16.50	6.50	6.00	11.13	0.33	0.69	N/A	11.78	3.41	10.00	4.65	7.26	0.75	18.00	15.63	14.00	2.500	1.500	3/8 x 3.00	5/8 x 4.00
GR870	7.63	14.88	2.770	18.91	7.59	7.00	11.37	0.35	0.78	N/A	11.50	2.97	11.76	5.65	7.45	0.75	21.00	18.38	15.63	2.750	1.625	3/8 x 2.87**	5/8 x 4.00**
GR880	8.63	17.00	3.090	20.96	8.86	8.00	12.52	0.57	1.03	N/A	12.50	2.84	12.25	5.98	8.34	0.75	24.00	21.00	17.88	3.000	1.875	1/2 x 2.81**	3/4 x 4.50**
GR8100	9.53	20.88	3.298	25.47	10.36	10.00	14.69	0.51	1.03	N/A	15.50	3.76	14.75	6.76	9.07	1.00	29.00	25.00	21.19	3.750	2.250	1/2 x 3.69**	7/8 x 5.00**

▲ See feature comparison chart.

FEATURE COMPARISON (821, 826, 832)

Size	Output Shaft Diameter Needed?	Mounting Footprint Needed?	Output Key Needed?	All Other Features	Grove Gear Flexaline Interchange	LEESON IRONMAN Interchange	Replace With Series Code Below:
821	Identical	Identical◊	Identical	Identical	✓	✓	GRG
							GRL
826	1.250"	Identical	Identical	Identical	✓	✓	GRG
	1.125"						GRL
832	1.500"	Identical	3/8 x 2.63	Identical	✓	✓	GRG
	1.375"						GRL

◊ If Accessory kit is removed, dimensions will vary. NOTE: If reducer is used without the accessory mounted, select based mounting dimensions on pages 52-53 (B, BM, BMQ).

Motor Mounting Dimensions

NEMA DIMENSIONS (Inches)

Series	LM		L1		LQ 48CZ/ 56C/140TC	180TC	LQ1 210TC	250TC	RQ		
	48CZ	56C/ 140TC	180TC/ 210TC	250TC					48CZ/ 56C/140TC	250TC	
GR813	5.63	6.07	N/A	N/A	3.46	N/A	N/A	N/A	3.09	N/A	N/A
GR815	6.16	6.60	N/A	N/A	3.99	N/A	N/A	N/A	3.62	N/A	N/A
GR818	6.26	6.70	N/A	N/A	4.09	N/A	N/A	N/A	3.59	N/A	N/A
GR821*	6.63	7.07	N/A	N/A	4.46	N/A	N/A	N/A	4.06	N/A	N/A
GR824	N/A	7.76	8.76	N/A	4.63	5.06	N/A	N/A	4.09	4.56	N/A
GR826*	N/A	8.32	9.32	N/A	5.19	5.62	N/A	N/A	4.82	5.13	N/A
GR830	N/A	8.82	9.82	N/A	5.95	6.15	6.56	N/A	5.32	5.63	N/A
GR832*	N/A	9.01	10.01	N/A	6.14	6.34	6.75	N/A	5.51	5.81	N/A
GR842	N/A	11.81	12.90	13.46	6.45	7.21	7.21	7.77	6.04	6.68	7.24
GR852	N/A	13.21	14.30	14.86	7.85	8.61	8.61	9.17	7.35	7.98	8.54
GR860	N/A	N/A	15.88	16.50	10.45	9.33	9.33	9.94	10.01	8.69	8.69
GR870	N/A	N/A	15.50	15.50	N/A	N/A	N/A	N/A	N/A	N/A	N/A
GR880	N/A	N/A	16.58	16.58	N/A	N/A	N/A	N/A	N/A	N/A	N/A

NEMA DIMENSIONS (Inches)

Frame	Ajb	AK	BD	BE	BE1	Bore Dia.	Keyway♦	BFb
48CZ	3.75	3.00	4.36	0.38	N/A	0.500	1/8 X 1/16	0.28
56C	5.88	4.50	6.50	0.38	N/A	0.625	3/16 X 3/32	0.41
140TC	5.88	4.50	6.50	0.38	N/A	0.875	3/16 X 3/32	0.41
180TC	7.25	8.50	9.00	N/A	0.50	1.125	1/4 X 1/8	0.53
210TC	7.25	8.50	9.00	N/A	0.50	1.375	5/16 X 5/32	0.53
250TC	7.25	8.50	9.00	N/A	0.50	1.625	3/8 X 3/16	0.53

IEC B5 & B3/B5 METRIC DIMENSIONS (Inches)◊

Series	LQ1				D100LD/D112MD	D132D	D63D	D71D	RQ			
	D63D	D71D	D80D	D90D					D80D	D90D	D132D	
GR813	2.62	2.65	2.89	N/A	N/A	N/A	2.45	2.47	2.71	N/A	N/A	N/A
GR815	3.15	3.18	3.42	N/A	N/A	N/A	2.98	3.00	3.24	N/A	N/A	N/A
GR818	3.25	3.28	3.52	N/A	N/A	N/A	2.95	2.97	3.21	N/A	N/A	N/A
GR821*	3.62	3.65	3.89	N/A	N/A	N/A	3.43	3.44	3.68	N/A	N/A	N/A
GR824	N/A	3.72	4.34	N/A	N/A	N/A	N/A	3.46	3.71	N/A	N/A	N/A
GR826*	N/A	4.28	4.90	4.90	5.30	N/A	N/A	4.09	4.72	4.72	N/A	N/A
GR830	N/A	4.78	5.41	5.41	5.88	N/A	N/A	4.59	5.22	5.22	N/A	N/A
GR832*	N/A	4.97	5.59	5.59	6.07	N/A	N/A	4.78	5.41	5.41	N/A	N/A
GR842	N/A	N/A	N/A	6.38	6.39	7.17	N/A	N/A	N/A	6.16	6.93	
GR852	N/A	N/A	N/A	7.78	7.78	8.57	N/A	N/A	N/A	7.46	8.24	

IEC B5 & B3/B5 METRIC DIMENSIONS (MM)

Frame	AJ	AK	BD	BE	Bore Dia.	Keyway♦	BF TAP	OD
D63D	115	95	117	10	11	4 X 2	M8 X 1.25	131
D71D	130	110	132	11	14	5 X 2.5	M8 X 1.25	146
D80D	165	130	165	15	19	6 X 3	M10 X 1.50	184
D90D	165	130	165	15	24	8 X 3.5	M10 X 1.50	184
D100LD/ D112MD	215	180	216	18	28	8 X 3.5	M12 X 1.75	237
D132D	265	230	267	18	38	10 X 4	M12 X 1.75	290

* Applies to double output shaft

** Key not provided with gear reducer. Keyway dimension shown.

♦ Keyway width by depth

◊ Mounting holes rotated 45 degrees from positions shown on Size GR860, Style FM with frame sizes 180TC-250TC.

■ 48CZ not available

● 180TC not available

♦ Metric IEC B5 input flange options are available only on quill input styles.

* Dimensions same for GRG and GRL Series

* Style F and FM only.

▼ Sizes 860-8100 are supplied with a fan. Dimensions refer to fan guard location.



For safety, purchaser or user should provide protective guards over shaft extensions and any couplings, sheaves and belts, sprockets and chains, etc., mounted thereon.

Single Reduction
Worm Gear Reducers

Double Reduction
Worm - Worm Gear Reducers

Double Reduction
Helical - Worm Gear Reducers

WASHGUARD® Reducers
and GEAR-MOTOR™

Ratio Multipliers

Accessories and
Additional Capabilities