

# Maximum Rating Tables

Size 813 • GR, NH, EL Series



Single Reduction  
Worm Gear Reducers

Double Reduction  
Worm - Worm Gear Reducers

Double Reduction  
Helical - Worm Gear Reducers

WASHGUARD® Reducers  
and GEAR+MOTOR™

Ratio Multipliers

Accessories and  
Additional Capabilities

Style B

Style H



**Size 813**

Ratio	Input RPM	Output RPM	Input HP	Output HP	Output Torque (lb-in)	Left Hand Catalog No.	Right Hand Catalog No.	Double Extension Catalog No.	Hollow Output Catalog No.
5	2500	500	1.528	1.429	180	_8130001	_8130013	_8130025	_8130501.10
	1750	350	1.248	1.158	209				
	1170	234	0.952	0.872	235				
	100	20	0.140	0.095	298				
7.5	2500	333	1.281	1.178	223	_8130002	_8130014	_8130026	_8130502.10
	1750	233	1.025	0.933	252				
	1170	156	0.770	0.689	278				
	100	13	0.118	0.072	339				
10	2500	250	1.016	0.912	230	_8130003	_8130015	_8130027	_8130503.10
	1750	175	0.823	0.729	263				
	1170	117	0.626	0.543	293				
	100	10	0.103	0.058	363				
15	2500	166	0.790	0.678	257	_8130004	_8130016	_8130028	_8130504.10
	1750	116	0.642	0.541	292				
	1170	78	0.491	0.402	325				
	100	6.7	0.090	0.042	401				
20	2500	125	0.681	0.562	283	_8130005	_8130017	_8130029	_8130505.10
	1750	87	0.551	0.445	320				
	1170	58	0.422	0.328	354				
	100	5.0	0.084	0.034	431				
25	2500	100	0.544	0.431	272	_8130006	_8130018	_8130030	_8130506.10
	1750	70	0.445	0.344	309				
	1170	46	0.344	0.255	344				
	100	4.0	0.074	0.027	423				
30	2500	83	0.481	0.364	276	_8130007	_8130019	_8130031	_8130507.10
	1750	58	0.395	0.290	314				
	1170	39	0.308	0.215	348				
	100	3.3	0.071	0.023	429				
40	2500	62	0.400	0.283	285	_8130008	_8130020	_8130032	_8130508.10
	1750	43	0.329	0.223	322				
	1170	29	0.258	0.165	355				
	100	2.5	0.066	0.017	432				
50	2500	50	0.346	0.232	292	_8130009	_8130021	_8130033	_8130509.10
	1750	35	0.285	0.182	327				
	1170	23	0.224	0.133	359				
	100	2.0	0.061	0.014	431				
60	2500	41	0.297	0.184	279	_8130010	_8130022	_8130034	_8130510.10
	1750	29	0.246	0.145	313				
	1170	19	0.195	0.107	345				
	100	1.7	0.058	0.011	415				
80	2500	31	0.144	0.081	163	_8130011	_8130023	_8130035	_8130511.10
	1750	21	0.121	0.064	183				
	1170	14	0.096	0.047	201				
	100	1.3	0.014	0.005	237				
100	2500	25	0.100	0.051	128	_8130012	_8130024	_8130036	_8130512.10
	1750	17	0.084	0.040	143				
	1170	11	0.067	0.029	156				
	100	1.0	0.010	0.003	184				

**How To Build a Part Number For Size GR813, NH813, EL813**

1. Select partial catalog number from the selection table
2. Replace leading “\_” with series code (GR, NH, EL)

**Example:**

Grove Gear IRONMAN, style B, 5:1 ratio, left hand output  
GR-B813-5-L  
GR8130001

Single Reduction  
Worm Gear Reducers





Double Reduction  
Worm - Worm Gear Reducers

Double Reduction  
Helical - Worm Gear Reducers

WASHGUARD® Reducers  
and GEAR+MOTOR™

Ratio Multipliers

Accessories and  
Additional Capabilities

	Style BM			Style HM	Style BMQ			Style HMQ	
									
NEMA C Input Flange ▲	Left Hand Catalog No.	Right Hand Catalog No.	Double Extension Catalog No.	Hollow Output Catalog No.	Left Hand Catalog No.	Right Hand Catalog No.	Double Extension Catalog No.	Hollow Output Catalog No.	Ratio
48CZ 56C	__8130109 __8130037	__8130121 __8130049	__8130133 __8130061	__8130537.10 __8130513.10	__8130181 __8130073	__8130193 __8130085	__8130205 __8130097	__8130561.10 __8130525.10	5
48CZ 56C	__8130110 __8130038	__8130122 __8130050	__8130134 __8130062	__8130538.10 __8130514.10	__8130182 __8130074	__8130194 __8130086	__8130206 __8130098	__8130562.10 __8130526.10	7.5
48CZ 56C	__8130111 __8130039	__8130123 __8130051	__8130135 __8130063	__8130539.10 __8130515.10	__8130183 __8130075	__8130195 __8130087	__8130207 __8130099	__8130563.10 __8130527.10	10
48CZ 56C	__8130112 __8130040	__8130124 __8130052	__8130136 __8130064	__8130540.10 __8130516.10	__8130184 __8130076	__8130196 __8130088	__8130208 __8130100	__8130564.10 __8130528.10	15
48CZ 56C	__8130113 __8130041	__8130125 __8130053	__8130137 __8130065	__8130541.10 __8130517.10	__8130185 __8130077	__8130197 __8130089	__8130209 __8130101	__8130565.10 __8130529.10	20
48CZ 56C	__8130114 __8130042	__8130126 __8130054	__8130138 __8130066	__8130542.10 __8130518.10	__8130186 __8130078	__8130198 __8130090	__8130210 __8130102	__8130566.10 __8130530.10	25
48CZ 56C	__8130115 __8130043	__8130127 __8130055	__8130139 __8130067	__8130543.10 __8130519.10	__8130187 __8130079	__8130199 __8130091	__8130211 __8130103	__8130567.10 __8130531.10	30
48CZ 56C	__8130116 __8130044	__8130128 __8130056	__8130140 __8130068	__8130544.10 __8130520.10	__8130188 __8130080	__8130200 __8130092	__8130212 __8130104	__8130568.10 __8130532.10	40
48CZ 56C	__8130117 __8130045	__8130129 __8130057	__8130141 __8130069	__8130545.10 __8130521.10	__8130189 __8130081	__8130201 __8130093	__8130213 __8130105	__8130569.10 __8130533.10	50
48CZ 56C	__8130118 __8130046	__8130130 __8130058	__8130142 __8130070	__8130546.10 __8130522.10	__8130190 __8130082	__8130202 __8130094	__8130214 __8130106	__8130570.10 __8130534.10	60
48CZ 56C	__8130119 __8130047	__8130131 __8130059	__8130143 __8130071	__8130547.10 __8130523.10	__8130191 __8130083	__8130203 __8130095	__8130215 __8130107	__8130571.10 __8130535.10	80
48CZ 56C	__8130120 __8130048	__8130132 __8130060	__8130144 __8130072	__8130548.10 __8130524.10	__8130192 __8130084	__8130204 __8130096	__8130216 __8130108	__8130572.10 __8130536.10	100

For input/ output shaft overhung load and thrust load ratings, refer to pages 419-422.

▲ Consult Factory for other motor flanges available.



# NH Series Dimensions

Styles: HMQ, HM, H

**CAST IRON**  
**NH SERIES**

Single Reduction  
Worm Gear Reducers

Double Reduction  
Worm - Worm Gear Reducers

Double Reduction  
Helical - Worm Gear Reducers

WASHGUARD® Reducers  
and GEAR+MOTOR™

Ratio Multipliers

Accessories and  
Additional Capabilities

## Style HMQ

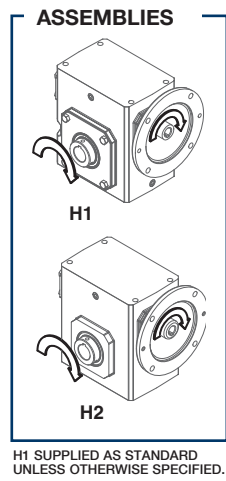
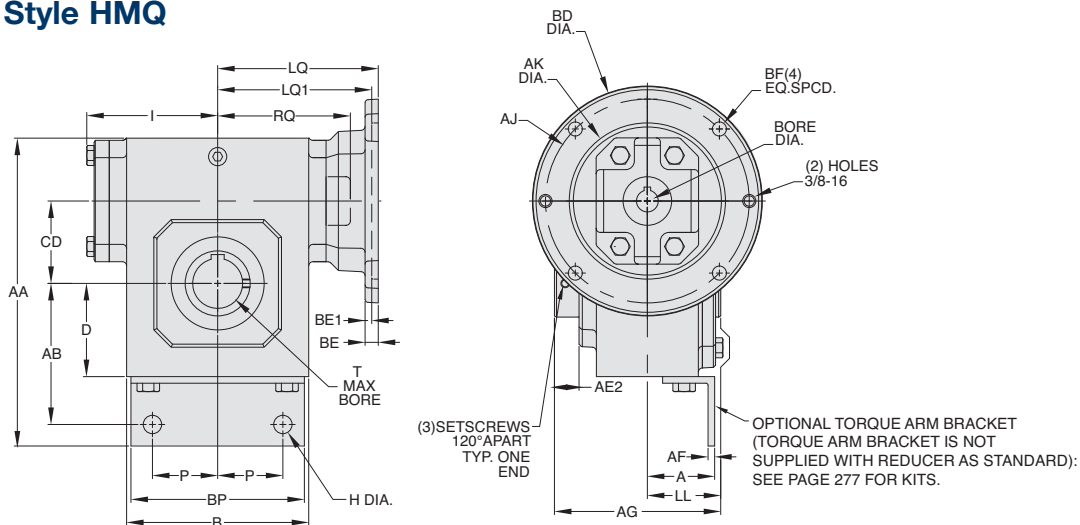

## Style HM

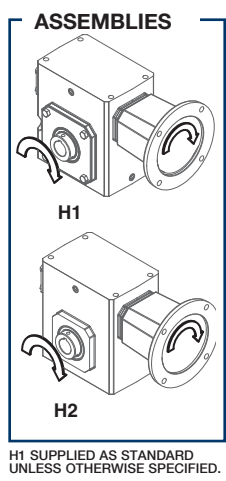
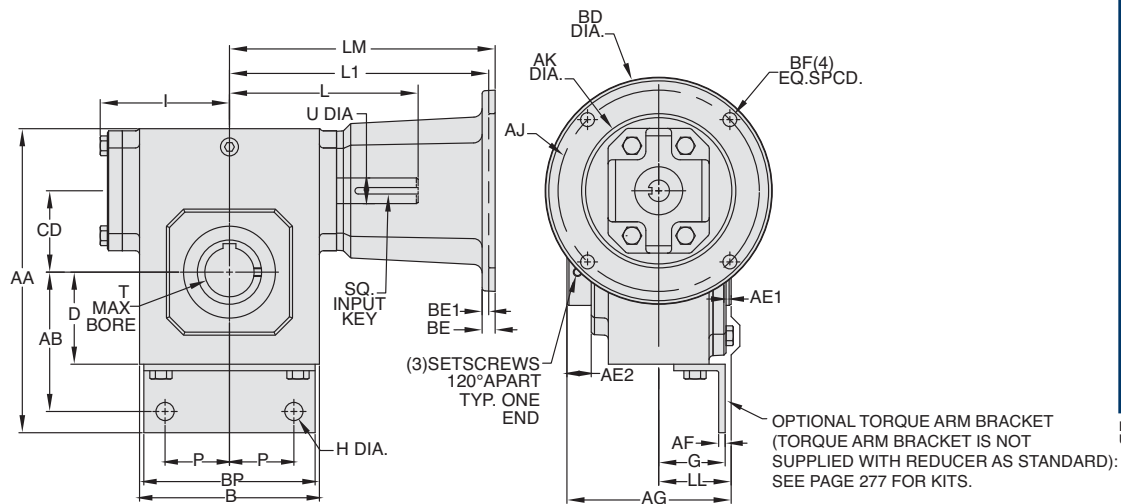

## Style H

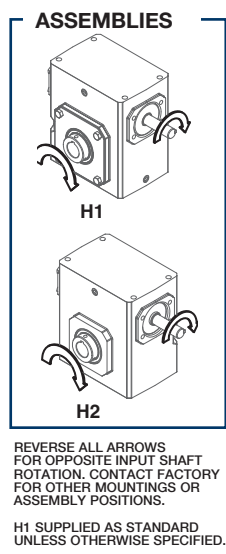
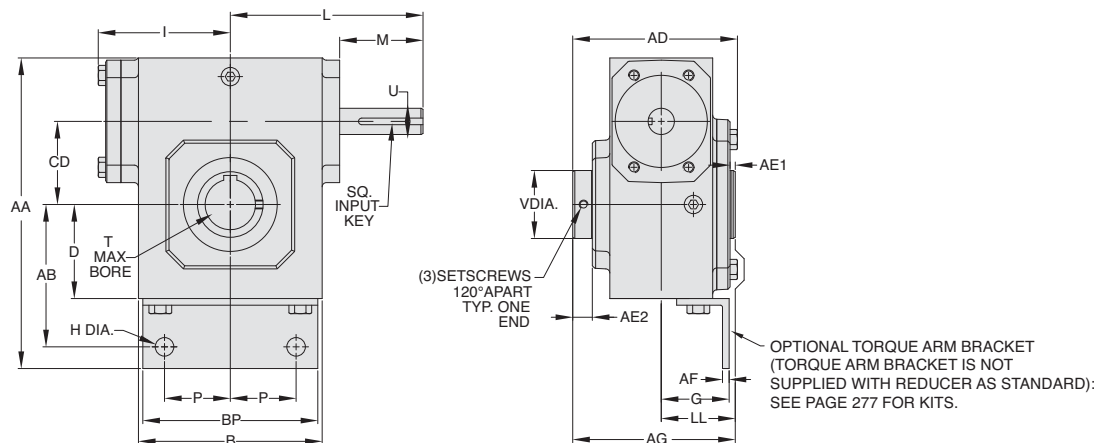



# NH Series Dimensions

Styles: HMQ, HM, H



Single Reduction  
Worm Gear Reducers

Double Reduction  
Worm - Worm Gear Reducers

Double Reduction  
Helical - Worm Gear Reducers

WASHQUARD® Reducers  
and GEAR+MOTOR™

Ratio Multipliers

Accessories and  
Additional Capabilities

## STYLE HMQ, HM, H DIMENSIONS (Inches)

Size	AA	AB	AD	AE1	AE2	AF	AG	B	C	CD	D	G	H	I	L	LL	M	P	V	T MAX +0.000 +0.0025	U +0.000 -0.0015	Input Key*	Output Key
NH813	6.660	3.100	3.900	0.500	0.530	0.190	4.750	3.800	4.660	1.330	1.720	1.880	0.530	2.610	3.820	2.380	1.760	1.380	1.000	0.625	0.500	1/8 x 1.00	3/16 x 1.50
NH815	7.000	3.260	3.590	0.376	0.510	0.190	4.080	4.060	5.000	1.540	1.880	1.820	0.530	3.140	4.350	1.880	1.760	1.380	1.000	0.625	0.625	3/16 x 1.38	3/16 x 1.50
NH818	7.440	3.440	3.830	0.551	0.560	0.190	4.290	4.500	5.440	1.750	2.060	1.820	0.530	3.240	4.450	1.980	1.760	1.380	1.440	1.000	0.625	3/16 x 1.38	1/4 x 3.00
NH821	8.000	3.690	3.570	0.300	0.850	0.190	4.650	4.500	6.000	2.060	2.310	1.820	0.530	3.610	4.820	2.120	1.760	1.380	1.940	1.500	0.625	3/16 x 1.38	3/8 x 3.00
NH824	8.880	4.070	4.160	0.180	0.560	0.190	4.650	5.250	6.880	2.380	2.690	1.940	0.530	3.770	5.510	2.120	2.380	1.880	1.940	1.500	0.750	3/16 x 1.38	3/8 x 3.00
NH826	9.380	4.320	4.150	0.595	0.560	0.190	4.650	5.750	7.380	2.630	2.940	1.940	0.530	4.340	6.070	2.120	2.380	1.880	1.940	1.500	0.750	3/16 x 1.63	3/8 x 3.00
NH830	10.250	4.760	4.670	0.460	0.560	0.250	5.160	6.620	8.250	3.380	3.380	2.320	0.530	4.840	6.570	2.380	2.380	2.380	2.510	1.938	0.875	3/16 x 1.63	1/2 x 3.00
NH832	12.060	5.570	5.830	0.490	0.570	0.250	6.310	8.000	10.060	3.250	4.190	2.870	0.530	5.020	6.760	2.950	2.380	3.510	2.510	1.938	0.875	3/16 x 1.63	1/2 x 3.00
NH842	14.000	6.380	7.530	1.000	0.630	0.380	8.500	9.750	11.500	4.250	4.500	3.260	0.530	6.100	9.570	4.250	3.470	3.690	2.750	2.188	1.250	1/4 x 2.50	1/2 x 3.00
NH852	15.190	6.760	8.810	1.620	0.970	0.380	10.500	11.000	12.690	5.250	4.880	3.630	0.530	7.500	10.880	5.250	3.380	4.620	4.260	3.438	1.250	1/4 x 3.00	7/8 x 3.44

## Motor Mounting Dimensions

### NEMA DIMENSIONS (Inches)

Size	LM		L1		LQ 48CZ/ 56C/140TC	180TC	LQ1		250TC	RQ			
	48CZ	56C/ 140TC	180TC/ 210TC	250TC			180TC	210TC		250TC	48CZ/ 56C/140TC	180TC	210TC
NH813	5.63	6.07	N/A	N/A	3.46	N/A	N/A	N/A	N/A	3.09	N/A	N/A	N/A
NH815	6.16	6.60	N/A	N/A	3.99	N/A	N/A	N/A	N/A	3.62	N/A	N/A	N/A
NH818	6.26	6.70	N/A	N/A	4.09	N/A	N/A	N/A	N/A	3.59	N/A	N/A	N/A
NH821	6.63	7.07	N/A	N/A	4.46	N/A	N/A	N/A	N/A	4.06	N/A	N/A	N/A
NH824	N/A	7.76	8.76	N/A	4.63	5.06	N/A	N/A	4.09	4.56	N/A	N/A	N/A
NH826	N/A	8.32	9.32	N/A	5.19	5.62	N/A	N/A	4.82	5.13	N/A	N/A	N/A
NH830	N/A	8.82	9.82	N/A	5.69	6.12	6.56	N/A	5.32	5.63	6.06	N/A	N/A
NH832	N/A	9.01	10.01	N/A	5.88	6.31	6.75	N/A	5.51	5.81	6.25	N/A	N/A
NH842	N/A	11.81	12.90	13.46	6.45	7.21	7.21	7.77	6.04	6.68	6.68	7.24	7.24
NH852	N/A	13.21	14.30	14.86	7.85	8.61	8.61	9.17	7.35	7.98	7.98	8.54	8.54

### NEMA DIMENSIONS (Inches)

Frame	AJ	AK	BD	BE	BE1	Bore Dia.	Keyway	BF
48CZ	3.75	3.00	4.36	0.38	N/A	0.500	1/8 X 1/16	0.28
56C	5.88	4.50	6.50	0.38	N/A	0.625	3/16 X 3/32	0.41
140TC	5.88	4.50	6.50	0.38	N/A	0.875	3/16 X 3/32	0.41
180TC	7.25	8.50	9.00	N/A	0.50	1.125	1/4 X 1/8	0.53
210TC	7.25	8.50	9.00	N/A	0.50	1.375	5/16 X 5/32	0.53
250TC	7.25	8.50	9.00	N/A	0.50	1.625	3/8 X 3/16	0.53

### IEC B5 & B3/B5 METRIC DIMENSIONS (Inches)\*

Size	LQ1					RQ						
	D63D	D71D	D80D	D90D	D100LD/ D112MD	D132D	D63D	D71D	D80D	D90D	D100LD/ D112MD	D132D
NH813	2.62	2.65	2.89	N/A	N/A	N/A	2.45	2.47	2.71	N/A	N/A	N/A
NH815	3.15	3.18	3.42	N/A	N/A	N/A	2.98	3.00	3.24	N/A	N/A	N/A
NH818	3.25	3.28	3.52	N/A	N/A	N/A	2.95	2.97	3.21	N/A	N/A	N/A
NH821	3.62	3.65	3.89	N/A	N/A	N/A	3.43	3.44	3.68	N/A	N/A	N/A
NH824	N/A	3.72	4.34	N/A	N/A	N/A	N/A	3.46	3.71	N/A	N/A	N/A
NH826	N/A	4.28	4.90	4.90	5.30	N/A	N/A	4.09	4.72	4.72	5.07	N/A
NH830	N/A	4.78	5.41	5.41	5.80	N/A	N/A	4.59	5.22	5.22	5.57	N/A
NH832	N/A	4.97	5.59	5.59	5.99	N/A	N/A	4.78	5.41	5.41	5.76	N/A
NH842	N/A	N/A	N/A	6.38	6.39	7.17	N/A	N/A	N/A	6.16	6.14	6.93
NH852	N/A	N/A	N/A	7.78	7.78	8.57	N/A	N/A	N/A	7.46	7.45	8.24

### IEC B5 & B3/B5 METRIC DIMENSIONS (MM)

Frame	AJ	AK	BD	BE	Bore Dia.	Keyway	BF TAP	OD
D63D	115	95	117	10	11	4 X 2	M8 X 1.25	131
D71D	130	110	132	11	14	5 X 2.5	M8 X 1.25	146
D80D	165	130	165	15	19	6 X 3	M10 X 1.50	184
D90D	165	130	165	15	24	8 X 3.5	M10 X 1.50	184
D100LD/ D112MD	215	180	216	18	28	8 X 3.5	M12 X 1.75	237
D132D	265	230	267	18	38	10 X 4	M12 X 1.75	290

- Max bore dimensions shown. For additional bores available, refer to page 20.
- ◆ Keyway width by depth
- 48CZ not available
- ◇ Metric IEC B5 input flange options are available only on quill input styles.
- \* Style H and HM only.

Note: Torque arm bracket available separately. Refer to page 277 for kits. If a special bracket is required, refer to Style BMQ dimensions for mounting pad dimensions on top/bottom of reducer.

**WARNING** For safety, purchaser or user should provide protective guards over shaft extensions and any couplings, sheaves and belts, sprockets and chains, etc., mounted thereon.

## GROVE GEAR OE SERIES INTERCHANGE GUIDE

Grove Gear OE Series	Grove Gear IRONMAN NH Series
YF	HMQ
YFC	HM
Y	H

Refer to page 8 for complete interchange guide for original Grove Gear OE Series products.