

This document is the property of REGAL BELOIT CORPORATION ("RBC") including its subsidiaries and divisions and contains proprietary information of RBC. This document is loaned on the express condition that neither it nor the information contained therein shall be disclosed to others without the express written consent of RBC, and that the information shall be used by the recipient only as approved expressly by RBC. This document shall be returned to RBC upon its request. This document may be subject to certain restrictions under U.S. export control laws and regulations.

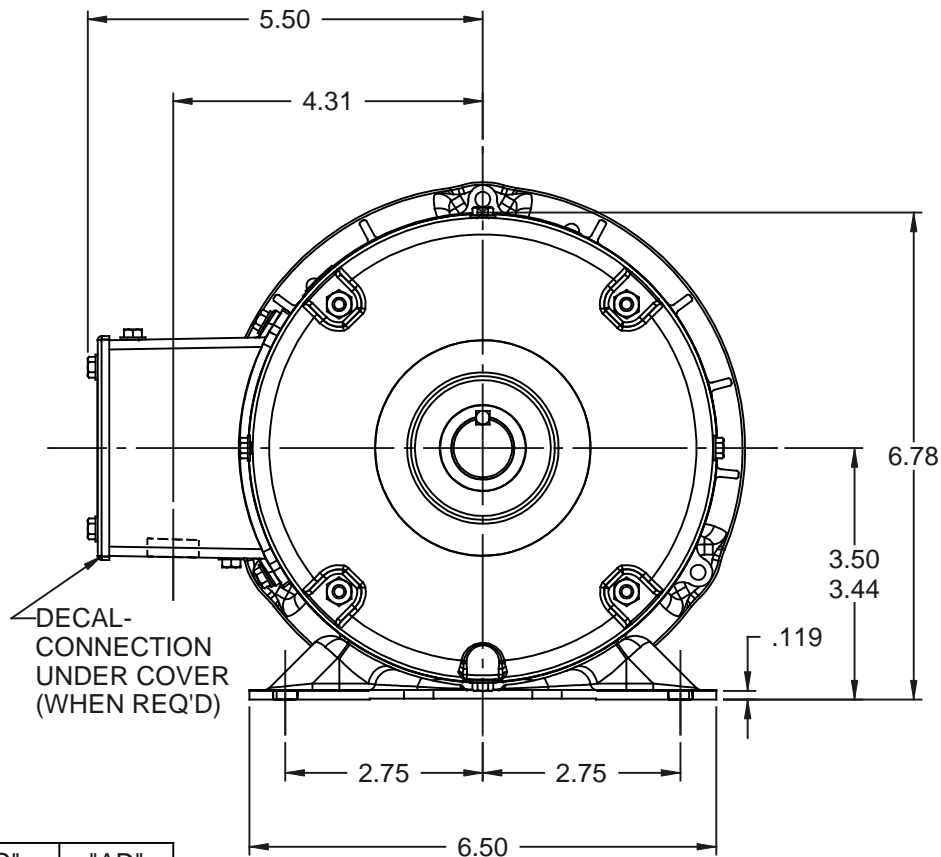
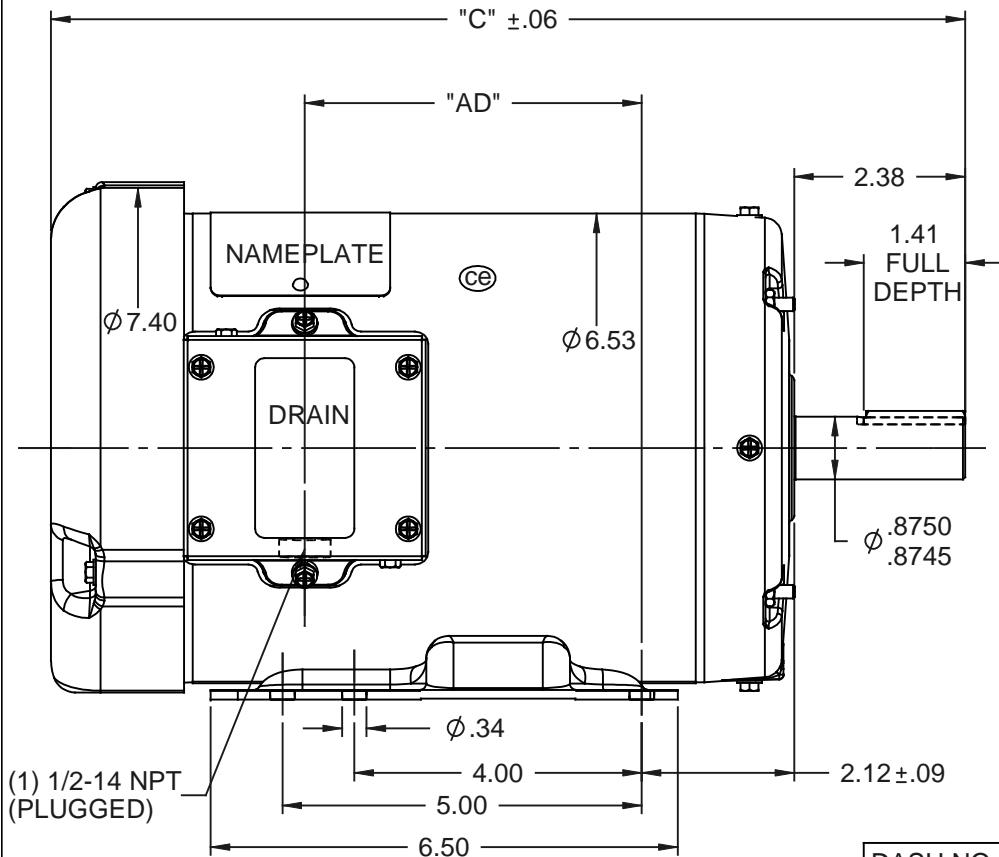

SPECIAL FEATURES  
 GASKETS THROUGHOUT  
 DRAIN HOLES IN ENDBELLS & CONDUIT BOX  
 SHAFT SEAL & V-RING  
 STAINLESS STEEL SHAFT, HARDWARE & NAMEPLATE

| DASH NO. | "C"   | "AD" |
|----------|-------|------|
| 700      | 12.75 | 4.69 |
| 750      | 13.25 | 5.19 |
| 800      | 13.75 | 5.69 |
| 850      | 14.25 | 6.19 |

|                        |          |                             |               |                 |                   |
|------------------------|----------|-----------------------------|---------------|-----------------|-------------------|
|                        |          | TOLERANCES UNLESS SPECIFIED |               |                 | DRAWN LST 10/3/08 |
|                        |          | DEC                         | INCHES        |                 | CHK               |
|                        |          | .X                          | ±.1           |                 | APPR              |
|                        |          | .XX                         | ±.03          |                 | SCALE 3:8         |
|                        |          | .XXX                        | ±.005         |                 | REF               |
|                        |          | .XXXX                       | ±.0005        | MAT'L WASHGUARD | FMF               |
| NO                     | REVISION | BY & DATE                   | CHK ANG ±1/2° | FINISH          | PAGE OF           |
| THIRD ANGLE PROJECTION |          | RFP                         |               | PREV            | SIZE              |
|                        |          | NETWORK FILE NAME           |               | DRAWING NO      |                   |
|                        |          |                             |               | A               |                   |
|                        |          |                             |               | 028889          |                   |
|                        |          |                             |               | REV             |                   |