



Low voltage MR16 flood with die cast aluminum housing, integral glare shield and tempered lens. Sleek good looks with minimal size. Supplied with 36" SPT-1 cord for installation on low voltage systems. MR16 lamp, 50 Watt max. Lamp not supplied.

Color: Verde green

Weight: 0.8 lbs

Project:	Type:
Prepared By:	Date:

Lamp Info		Ballast Info	
Type	MR16	Type	N/A
Watts	50W	120V	N/A
Shape/Size	N/A	208V	N/A
Base	N/A	240V	N/A
ANSI	N/A	277V	N/A
Hours	4,000	Input Watts	N/A
Lamp Lumens	N/A		
Efficacy	N/A		

Technical Specifications

Compliance

UL Listed:

Suitable for wet locations. Suitable for mounting within 4ft (1.2m) of the ground.

Trade Agreements Act Compliant:

This product is a product of Cambodia and a "designated country" end product that complies with the Trade Agreements Act

Construction

Swivels:

1/2" NPS threaded arm with serrated locking swivel fits all standard mounting boxes. EZ Grip locknuts color matched to fixture.

Housings:

Precision die-cast aluminum

Electrical

Voltage:

12V

Sockets:

Bipin GU5.3 with 36" SPT-1 cord.

Dimensions

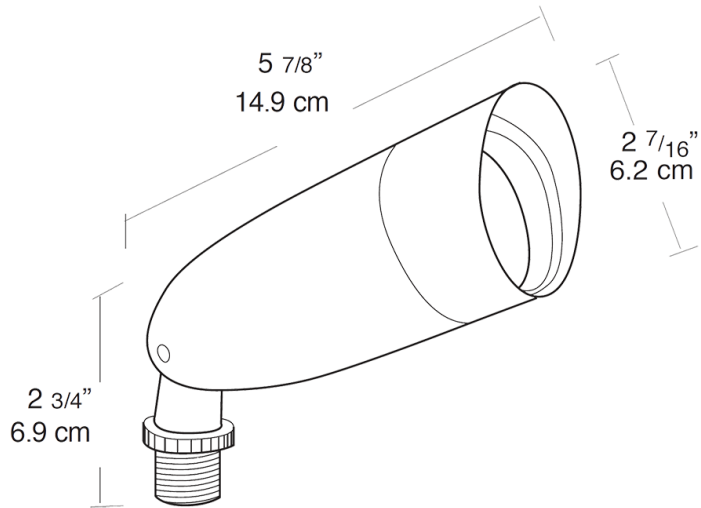

Features

- Rugged die cast aluminum housing with polyester powder coat finish
- Deep Glare Shield
- weatherproof lens and gasket
- "O" Ring seal for full weather protection
- No-rust brass & stainless steel external hardware
- Rugged mounting arm has 1/2" threads and pivots 180
- EZ Grip locknuts are color matched to fixture and can be tightened with fingers, pliers or screwdriver