

ROTATION
BI-DIRECTIONAL
SEE NOTE 6

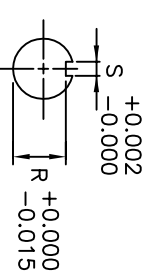
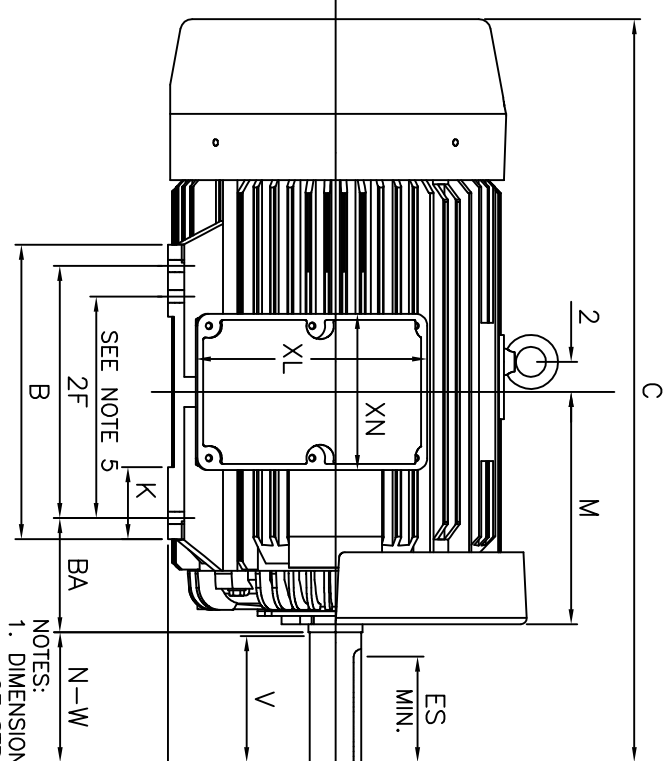
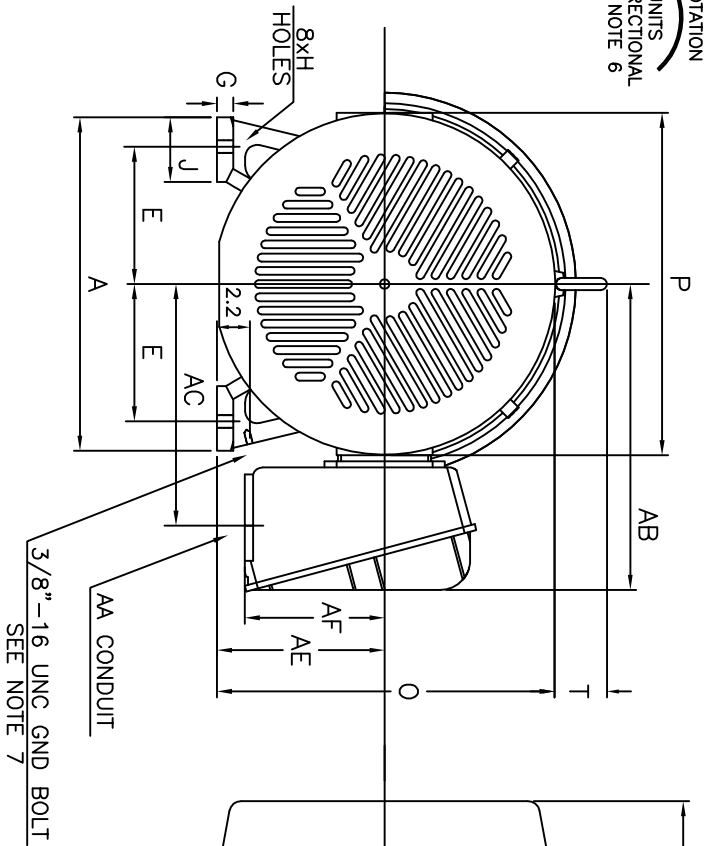

UNITS: INCHES

| FRAME SIZE | MOTOR DIMENSIONS | | | | | | | | | | CONDUIT BOX | | | | | | | |
|------------|------------------|------|------|-------|-----|-----|-----|------|------|------|-------------|--------|------|------|-------|-----|------|------|
| | A | B | C | D | G | J | K | M | O | P | T | AA[PT] | AB | AC | AE | AF | XL | XN |
| 444T/445T | 21.9 | 19.3 | 48.7 | 11.00 | 1.1 | 4.3 | 4.8 | 15.8 | 22.0 | 22.4 | 3.6 | 3.00 | 20.2 | 15.9 | 11.00 | 9.2 | 15.2 | 10.3 |

| FRAME SIZE | MOUNTING | | | | SHAFT EXTENSION | | | | KEY SEAT | | | BEARINGS | | | MAXIMUM WEIGHT |
|------------|----------|-------------|------|------|-----------------|------|-------|-------|----------|------|---------|----------|-----------|--|----------------|
| | E | 2F | H | BA | N-W | V | U | R | S | ES | LS | OS | | | |
| 444T/445T | 9.00 | 14.50/16.50 | 0.81 | 7.50 | 8.50 | 8.25 | 3.375 | 2.880 | 0.875 | 6.88 | NU318C3 | 6318C3 | 2000 lbs. | | |

CUSTOMER: _____ MOTOR MODEL NO.: _____ TAG NO's: _____

P.O. NO.: _____ HP: _____ VOLTAGE: _____ RPM(SYN.): _____ HZ: _____
 FRAME SIZE: _____ PRODUCT TYPE: EOP III 840 & 841
 COMMENTS: _____

PER: _____ DATE: _____

TOSHIBA RESERVES THE RIGHT TO MAKE CHANGES OF TECHNICAL IMPROVEMENT AND THE DATA MAY CHANGE WITHOUT NOTICE PRELIMINARY
 DO NOT USE FOR CONSTRUCTION, INSTALLATION, OR APPLICATION PURPOSES UNLESS THE DRAWING IS MARKED AS CERTIFIED CERTIFIED

- NOTES:
1. DIMENSION V REPRESENTS LENGTH OF STRAIGHT PART OF SHAFT
 2. MAIN CONDUIT BOX MAY BE ROTATED IN 90° INCREMENTS
 3. KEY DIMENSIONS EQUAL S x S x 6.91 (MOTOR SUPPLIED WITH KEY)
 4. MOTOR WEIGHT SHOWN IS MAXIMUM HORSEPOWER IN FRAME
 5. THIS DIMENSION EQUALS 2F FOR 444T MOUNTING
 6. STANDARD PRODUCT USE BI-DIRECTIONAL FAN, OPPOSITE ROTATION AVAILABLE ONLY BY CONNECTION CHANGE
 7. FRAME GROUND BOLT STANDARD ON 841 PRODUCT

STANDARD (NO AUX. BOXES)
 RTD AUX. BOX
 SPACE HEATER AUX. BOX
 BEARING RTD's

TOSHIBA
 TOSHIBA INTERNATIONAL CORPORATION
 TOTALLY-ENCLOSED FAN-COOLED
 HORIZONTAL FOOT-MOUNTED
 3 PHASE INDUCTION MOTOR
 F1 ASSEMBLY

XT SERIES
 VISIT OUR WEBSITE AT:
 www.toshiba.com/ind

TYPICAL MOTOR PERFORMANCE DATA

Model: B1256FLF4BSHJ01

| | | | | | | | | |
|-----------|----|------------|--------|-------|----------------|-------------|----------|--------------|
| HP | kW | Pole | FL RPM | Frame | Voltage | Hz | Phase | FL Amps |
| 125 | 90 | 6 | 1185 | 445T | 230/460 | 60 | 3 | 312/156 |
| Enclosure | IP | Ins. Class | S.F. | Duty | NEMA Nom. Eff. | NEMA Design | kVA Code | Ambient (°C) |
| TEFC | 56 | F | 1.15 | CONT | 95.4 | B | G | 40 C |

| | | | | | |
|--------------|-------|------|---------|----------------|------------------|
| Load | HP | kW | Amperes | Efficiency (%) | Power Factor (%) |
| Full Load | 125 | 93.2 | 156.0 | 95.5 | 79.1 |
| ¾ Load | 93.75 | 69.9 | 123.3 | 95.6 | 77.0 |
| ½ Load | 62.50 | 46.6 | 95.0 | 95.5 | 69.0 |
| ¼ Load | 31.25 | 23.3 | 73.5 | 89.8 | 44.3 |
| No Load | | | 63.2 | | 2.8 |
| Locked Rotor | | | 907.00 | | 32.9 |

| | | | | |
|-------------------|----------------------|-----------------|--------------------|-------------------------------|
| Torque | | | | Rotor wk ² |
| Full Load (lb-ft) | Locked Rotor (% FLT) | Pull Up (% FLT) | Break Down (% FLT) | Inertia (lb-ft ²) |
| 554 | 205 | 185 | 230 | 66.10 |

| | | | | | |
|--------------------|-----|---------------------------|-----------|--------|----------------------------|
| Safe Stall Time(s) | | Sound Pressure dB(A) @ 1M | Bearings* | | Approx. Motor Weight (lbs) |
| Cold | Hot | | DE | NDE | |
| 35 | 14 | - | NU318C3 | 6318C3 | |

*Bearings are the only recommended spare part(s).

Motor Options:
Product Family:EQPIII 841
Mounting:Footed,Shaft:T Shaft

| | |
|-------------|--|
| Customer | |
| Customer PO | |
| Sales Order | |
| Project # | |

Tag:

All characteristics are average expected values.

TOSHIBA INTERNATIONAL CORPORATION · HOUSTON, TEXAS U.S.A.

| | | | | | |
|-------------|----------|------------------|-------------|-------------|---------------|
| Engineering | amills | Doc. Written By | D. Suarez | Doc.# / Rev | MPCF-1119 / 0 |
| Engr. Date | 2/7/2012 | Doc. Approved By | M. Campbell | Doc. Issued | 6/8/2011 |

SPEED TORQUE/CURRENT CURVE

Model: B1256FLF4BSHJ01

| | | | | | | | | |
|-------------------|---|-------------------|------------------|-------------|----------------|-------------|----------|----------------|
| HP | kW | Pole | FL RPM | Frame | Voltage | Hz | Phase | FL Amps |
| 125 | 90 | 6 | 1185 | 445T | 230/460 | 60 | 3 | 312/156 |
| Enclosure | IP | Ins. Class | S.F. | Duty | NEMA Nom. Eff. | NEMA Design | kVA Code | Ambient (°C) |
| TEFC | 56 | F | 1.15 | CONT | 95.4 | B | G | 40 C |
| Locked Rotor Amps | Rotor wk ² Inertia (lb-ft ²) | Torque | | | | | | Break Down (%) |
| | | Full Load (lb-ft) | Locked Rotor (%) | Pull Up (%) | | | | |
| 907.00 | 66.10 | 554 | 205 | 185 | | | 230 | |

Design Values

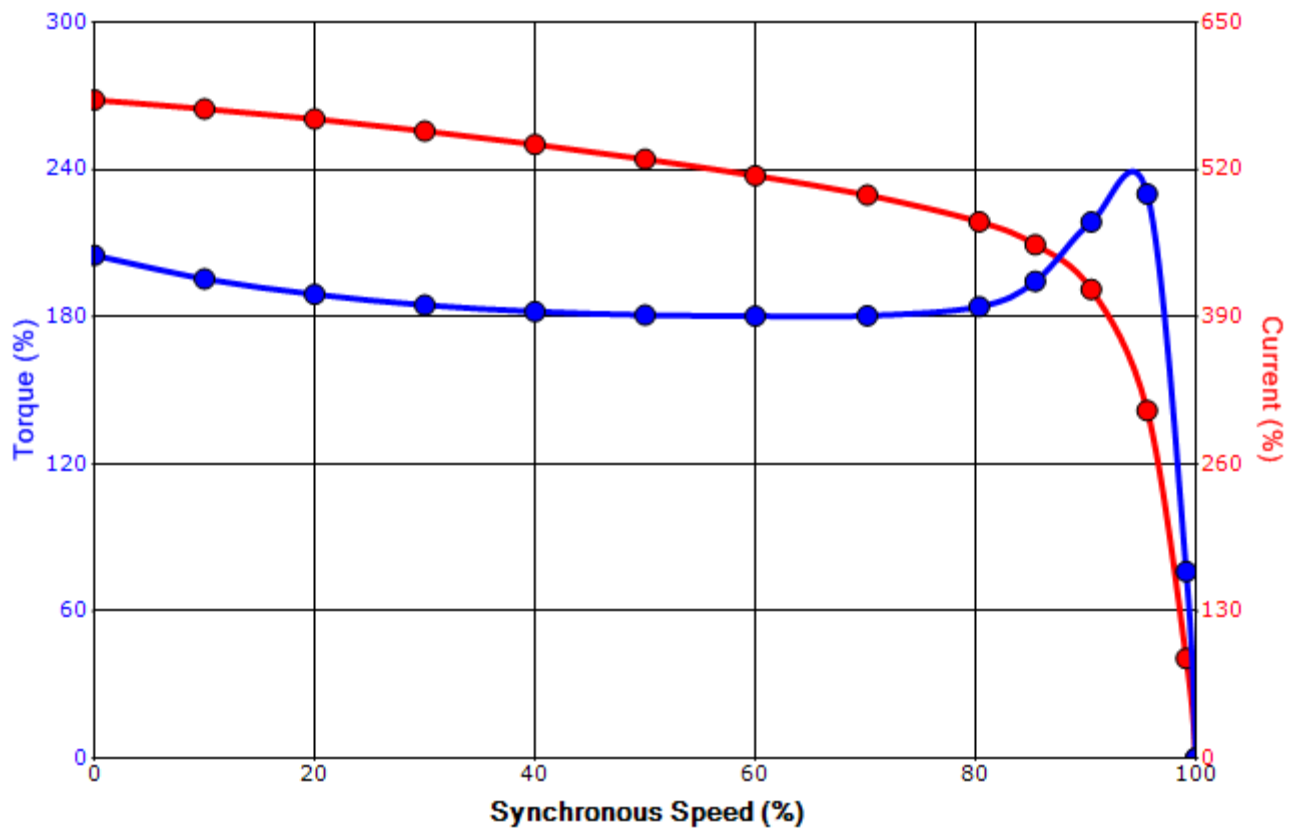

| | | | |
|-------------|--|--|-----|
| Customer | | wk ² Load Inertia (lb-ft ²) | - |
| Customer PO | | Load Type | - |
| Sales Order | | Voltage (%) | 100 |
| Project # | | Accel. Time | - |

Tag: _____

All characteristics are average expected values.

TOSHIBA INTERNATIONAL CORPORATION · HOUSTON, TEXAS U.S.A.

| | | | | | |
|-------------|----------|------------------|-------------|-------------|---------------|
| Engineering | amills | Doc. Written By | D. Suarez | Doc.# / Rev | MPCF-1121 / 0 |
| Engr. Date | 2/7/2012 | Doc. Approved By | M. Campbell | Doc. Issued | 6/8/2011 |

Motor Connection Diagram 3 Leads - Delta Connection



Switch L1 and L2 to reverse rotation

Each lead may consist of more than one cable.
If multiple cables represent a single lead, each one
of them will be labeled with the appropriate lead number.