

1/2"-13 UNC GND BOLT
SEE NOTE 7

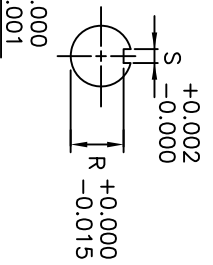
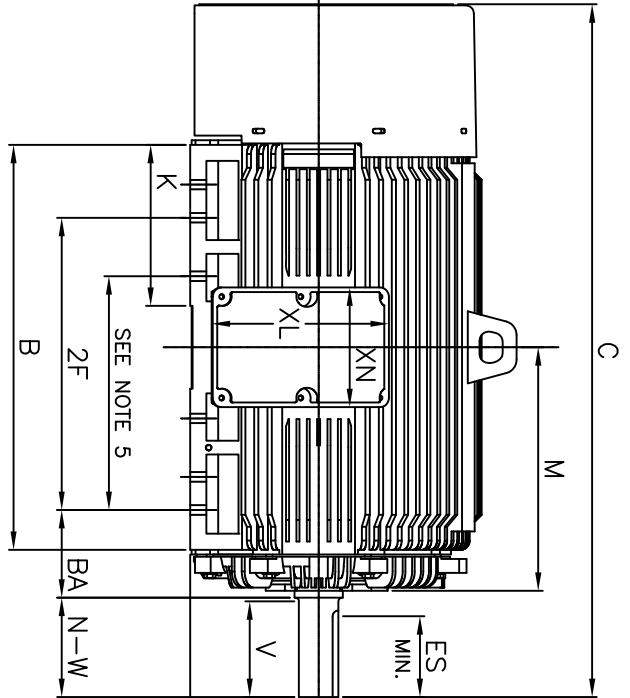

UNITS: INCHES

FRAME SIZE	MOTOR DIMENSIONS										CONDUIT BOX								MAXIMUM WEIGHT
	A	B	C	D	G	J	K	M	O	P	T	A[NPT]	AB	AC	AE	AF	XL	XN	
N447T/N449T	22.0	34.7	59.3	11.00	1.4	4.6	13.8	20.9	25.0	27.0	3.0	4.00	24.0	19.7	11.00	9.2	15.2	10.2	
N447TS/N449TS	22.0	34.7	55.6	11.00	1.4	4.6	13.8	20.9	25.0	27.0	3.0	4.00	24.0	19.7	11.00	9.2	15.2	10.2	
FRAME SIZE	MOUNTING				SHAFT EXTENSION				KEY SEAT				BEARINGS				MAXIMUM WEIGHT		
	E	2F	H	BA	N-W	V	U	R	S	ES	US ROLLER	US BALL 6P	US BALL 4P	OS 4~8P	US BALL 2P	OS 2P			
N447T/N449T	9.00	20.00/25.00	0.82	7.50	8.50	8.25	3.375	2.880	0.875	6.88	NU322C3	6322C3	6318C3	6318C3	-	-			
N447TS/N449TS	9.00	20.00/25.00	0.82	7.50	4.75	4.50	2.375	2.021	0.625	3.00	-	6318C3	6318C3	6318C3	6313C3	6313C3			
																3800 lbs.			

- NOTES:
- DIMENSION V REPRESENTS LENGTH OF STRAIGHT PART OF SHAFT
 - MAIN CONDUIT BOX MAY BE ROTATED IN 90° INCREMENTS
 - KEY DIMENSIONS EQUAL S x S x 6.91 (MOTOR SUPPLIED WITH KEY)
 - MOTOR WEIGHT SHOWN IS MAXIMUM HORSEPOWER IN FRAME
 - THIS DIMENSION EQUALS 2F FOR N447T MOUNTING
 - STANDARD PRODUCT USE BI-DIRECTIONAL FAN. OPPOSITE ROTATION AVAILABLE ONLY BY CONNECTION CHANGE
 - FRAME GROUND BOLT STANDARD ON 841 PRODUCT

CUSTOMER: _____ MOTOR MODEL NO.: _____ TAG NO's.: _____

P.O. NO.: _____ HP: _____ VOLTAGE: _____ RPM(SYN.): _____ HZ: _____
 FRAME SIZE: _____ PRODUCT TYPE: IEFEC EOP III 840
 COMMENTS: _____

PER: _____ DATE: _____

TOSHIBA RESERVES THE RIGHT TO MAKE CHANGES OF TECHNICAL IMPROVEMENT AND THE DATA MAY CHANGE WITHOUT NOTICE PRELIMINARY
 DO NOT USE FOR CONSTRUCTION, INSTALLATION, OR APPLICATION PURPOSES UNLESS THE DRAWING IS MARKED AS CERTIFIED CERTIFIED

- STANDARD (NO AUX. BOXES)
- RTD AUX. BOX
- SPACE HEATER AUX. BOX
- BEARING RTD's

TOSHIBA
TOSHIBA INTERNATIONAL CORPORATION

TOTALLY-ENCLOSED FAN-COOLED
HORIZONTAL FOOT-MOUNTED
3 PHASE INDUCTION MOTOR
F1 ASSEMBLY

XT SERIES
VISIT OUR WEBSITE AT:
www.toshiba.com/ind

TYPICAL MOTOR PERFORMANCE DATA

Model: B2006FLF4OSHJL

HP	kW	Pole	FL RPM	Frame	Voltage	Hz	Phase	FL Amps
200	150	6	1185	N449T	575	60	3	189
Enclosure	IP	Ins. Class	S.F.	Duty	NEMA Nom. Eff.	NEMA Design	kVA Code	Ambient (°C)
TEFC	56	F	1.15	CONT	96.2	B	G	40 C

Load	HP	kW	Amperes	Efficiency (%)	Power Factor (%)
Full Load	200	149.1	189.0	96.2	82.3
¾ Load	150.00	111.9	149.0	95.5	79.0
½ Load	100.00	74.6	113.1	93.7	70.7
¼ Load	50.00	37.3	85.2	88.1	49.9
No Load			77.0		3.2
Locked Rotor			1159.00		24.6

Torque				Rotor wk ² Inertia (lb-ft ²)
Full Load (lb-ft)	Locked Rotor (% FLT)	Pull Up (% FLT)	Break Down (% FLT)	
886	155	135	250	130.94

Safe Stall Time(s)		Sound Pressure dB(A) @ 1M	Bearings*		Approx. Motor Weight (lbs)
Cold	Hot		DE	NDE	
34	12	-	NU322C3	6318C3	

*Bearings are the only recommended spare part(s).

Motor Options:
Product Family:EQPIII 841
Mounting:Footed,Shaft:T Shaft

Customer	
Customer PO	
Sales Order	
Project #	

Tag:

All characteristics are average expected values.

TOSHIBA INTERNATIONAL CORPORATION · HOUSTON, TEXAS U.S.A.

Engineering	garce	Doc. Written By	D. Suarez	Doc.# / Rev	MPCF-1119 / 0
Engr. Date	8/21/2015	Doc. Approved By	M. Campbell	Doc. Issued	6/8/2011

SPEED TORQUE/CURRENT CURVE

Model: B2006FLF4OSHJL

HP	kW	Pole	FL RPM	Frame	Voltage	Hz	Phase	FL Amps
200	150	6	1185	N449T	575	60	3	189
Enclosure	IP	Ins. Class	S.F.	Duty	NEMA Nom. Eff.	NEMA Design	kVA Code	Ambient (°C)
TEFC	56	F	1.15	CONT	96.2	B	G	40 C
Locked Rotor Amps	Rotor wk ² Inertia (lb-ft ²)	Torque						Break Down (%)
		Full Load (lb-ft)	Locked Rotor (%)	Pull Up (%)				
1159.00	130.94	886	155	135			250	

Design Values

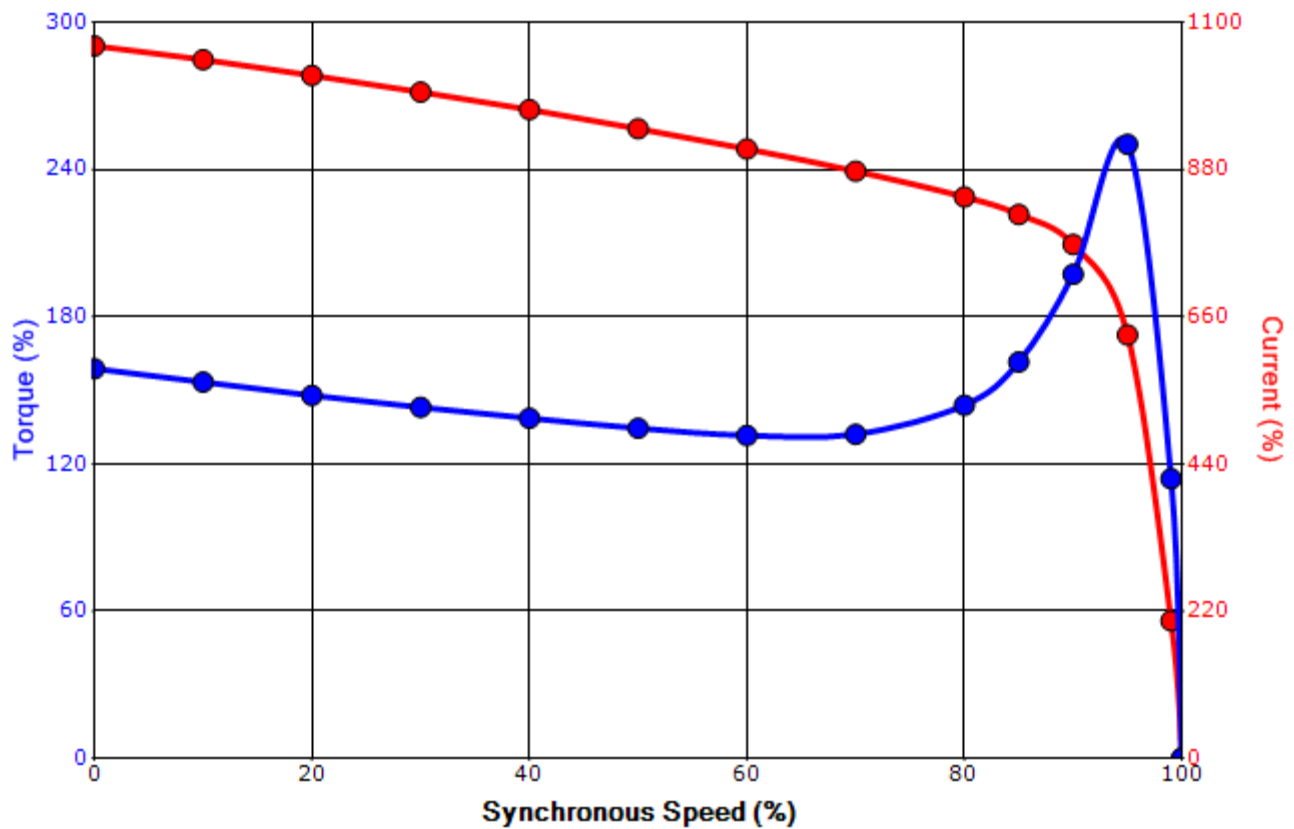

Customer		wk ² Load Inertia (lb-ft ²)	-
Customer PO		Load Type	-
Sales Order		Voltage (%)	100
Project #		Accel. Time	-

Tag:

All characteristics are average expected values.

TOSHIBA INTERNATIONAL CORPORATION · HOUSTON, TEXAS U.S.A.

Engineering	garce	Doc. Written By	D. Suarez	Doc.# / Rev	MPCF-1121 / 0
Engr. Date	8/21/2015	Doc. Approved By	M. Campbell	Doc. Issued	6/8/2011

Motor Connection Diagram 3 Leads - Delta Connection



Switch L1 and L2 to reverse rotation

Each lead may consist of more than one cable.
If multiple cables represent a single lead, each one
of them will be labeled with the appropriate lead number.