

INDEX	SAS-000900
REV. LEVEL	01
SHEET	1 OF 1

TOSHIBA/HOUSTON

DRIP-PROOF FULLY-GUARDED
HORIZONTAL FOOT-MOUNTED

Fr. 254T-256T

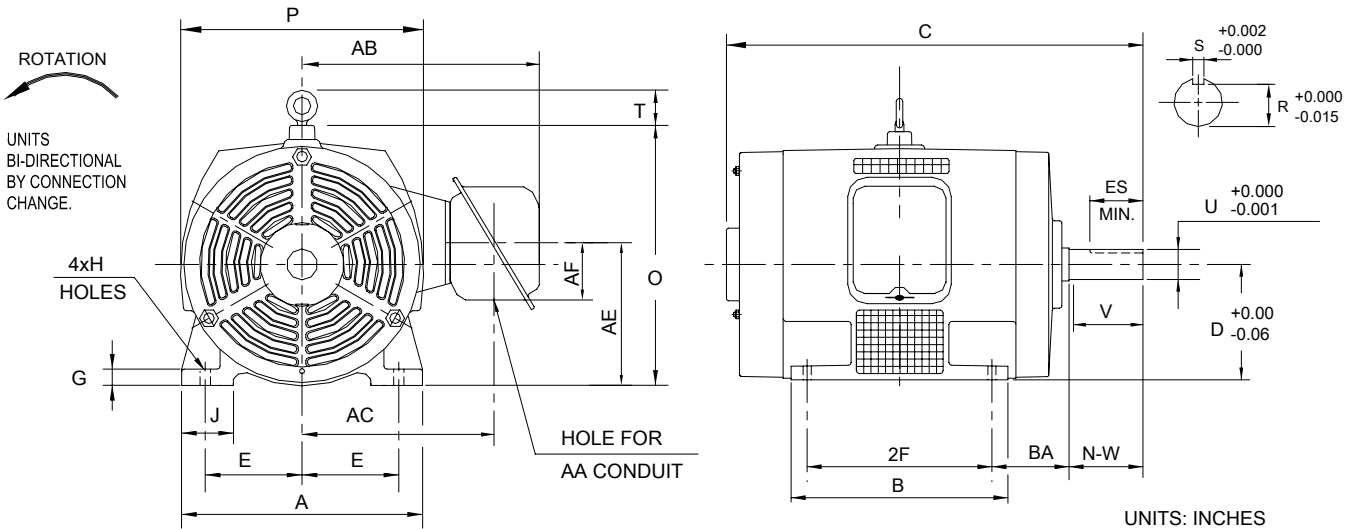

FRAME SIZE	MOUNTING					CONDUIT BOX					
	E	2F	H	BA	AA	AB	AC	AE	AF	XL	XN
254T	5.00	8.25	0.53	4.25	2.05	10.83	8.82	8.27	3.54	--	--
256T	5.00	10.00	0.53	4.25	2.05	10.83	8.82	8.27	3.54	--	--

FRAME SIZE	MOTOR DIMENSIONS									
	A	B	C	D	G	J	M	O	T	P
254T	12.20	9.84	20.67	6.25	0.66	3.15	--	12.3	2.3	12.80
256T	12.20	11.57	22.40	6.25	0.66	3.15	--	12.3	2.3	12.80

FRAME SIZE	SHAFT EXTENSION			KEY SEAT			BEARINGS		MAXIMUM WEIGHT
	N-W	V	U	R	S	ES	LS	OS	
254T/256T	4.00	3.90	1.625	1.416	0.375	2.875	6310ZZ	6208ZZ	292 lbs.

- NOTES:
- DIMENSION V REPRESENTS LENGTH OF STRAIGHT PART OF SHAFT.
 - CONDUIT BOX MAY BE ROTATED IN 90° INCREMENTS AND MAY BE MOUNTED ON OPPOSITE SIDE ON SPECIAL ORDER.
 - KEY DIMENSIONS EQUAL S x S x 2.88 (MOTOR SUPPLIED WITH KEY)
 - MOTOR WEIGHT SHOWN IS MAXIMUM HORSEPOWER IN FRAME.

ALL DATA SUBJECT TO CHANGE WITHOUT NOTICE.
FOR CONSTRUCTION USE ONLY CERTIFIED DATA.

CERTIFIED DATA

CUSTOMER: _____ P.O. NO.: _____ TAG NO.: _____
 MOTOR MODEL NO.: **0154DPSC31A-P** TOSHIBA FILE NO.: _____
 HP: **15** RPM (SYN.): **1800** VOLTAGE: **575** Hz: **60**
 FRAME SIZE: **254T** LOG NO.: _____ LOG REV. LEVEL: _____
 REMARKS: _____

PER: _____ ISSUE DATE: _____ SUPERSEDES: _____

TOSHIBA

Reliability in Motion

TOSHIBA INTERNATIONAL CORPORATION

INDUSTRIAL DIVISION

PO BOX 40906

HOUSTON TX 77240

(713) 466-0277

(800) 231-1412

FAX (713) 466-8773

SPARE PARTS (RECOMMENDED)

OTHER THAN THE GREASE USED FOR RE-GREASABLE BEARINGS, **TOSHIBA** ADVISES THAT THERE ARE NO "USE" PARTS. THE ONLY INSURANCE SPARES THAT **TOSHIBA** SUGGESTS FOR THESE SQUIRREL CAGE INDUCTION MOTORS ARE INDUSTRY STANDARD, AND COMMERCIALY AVAILABLE ANTI-FRICTION BEARINGS, AS NOTED BELOW.

MOTOR COMPONENTS (SUCH AS TERMINAL BOXES, FAN COVERS, MACHINED PARTS) ARE AVAILABLE UPON SPECIAL REQUEST. IN THIS CASE, PLEASE ADVISE OUR ORDER ENTRY DEPARTMENT THE MODEL AND SERIAL NUMBERS (FOUND ON THE MOTOR NAMEPLATE) , AND A DESCRIPTION OF THE COMPONENT REQUIRED. THEY WILL THEN FURNISH THE CURRENT PART NUMBER, PRICE AND AVAILABILITY.

(NOTE: OUR INTERNAL PART NUMBERS ARE SUBJECT TO CHANGE WITHOUT NOTICE, AND ARE NOT PUBLISHED).

PLEASE ADVISE IF YOU HAVE ANY QUESTIONS.

CUSTOMER:
PURCHASE ORDER #
Customer Tag:

TOSHIBA FILE #
MODEL # 0154DPSC31A-P
HP / RPM / ENCL / FRAME: 15 / 1800 / ODP / 254T
DRIVE END BEARING: 6310ZZ
OPPOSITE DRIVE END BEARING: 6208ZZ

Prepared By:
Date: