

NOTE:  
LIFTING RINGS  
(2) 180° APART  
FOR MOTOR  
LIFTING ONLY

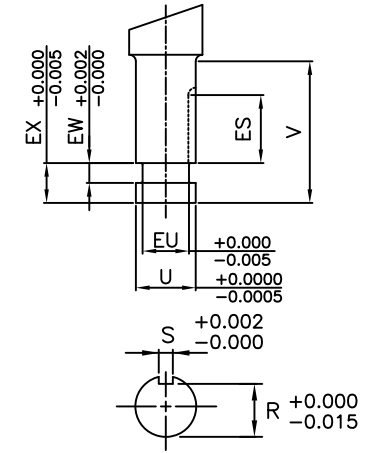
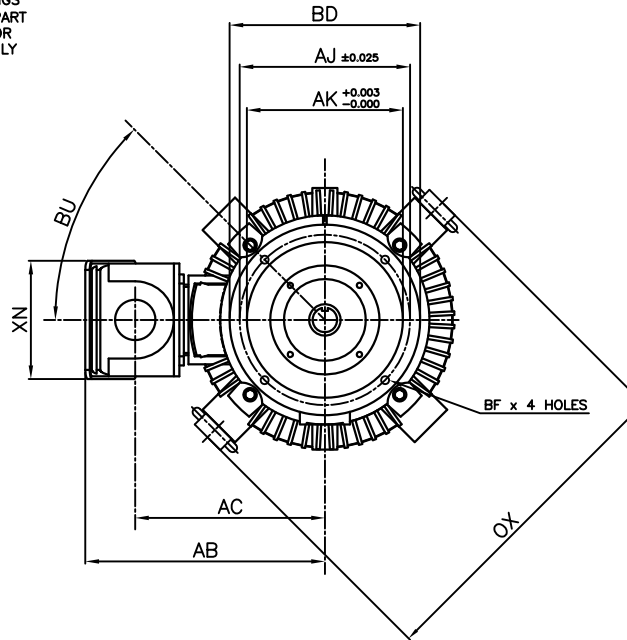

- NOTES:
1. DIMENSION V REPRESENTS LENGTH OF STRAIGHT PART OF SHAFT
  2. MAIN CONDUIT BOX MAY BE ROTATED IN 90° INCREMENTS
  3. KEY DIMENSIONS EQUAL S x S x ES (MOTOR SUPPLIED WITH KEY)
  4. MOTOR WEIGHT SHOWN IS MAXIMUM HORSEPOWER IN FRAME
  5. STANDARD PRODUCT USE BI-DIRECTIONAL FAN. OPPOSITE ROTATION AVAILABLE ONLY BY CONNECTION CHANGE

UNITS: INCHES

FRAME SIZE	MOTOR DIMENSIONS					P-FLANGE DIMENSIONS								SHAFT EXTENSION DIMENSIONS									
	AG	C	P	OX	BU	BB	BE	BF	BD	BV	AK	AJ	AH	EU	U	V	R	S	ES	EW	EX		
440HP16	58.3	62.8	22.2	28.8	45°	0.25	1.2	0.69	16.5	24.0	13.50	14.75	4.50	1.75	2.125	4.50	1.845	0.500	3.03	0.375	0.75		
440HP20	58.3	62.8	22.2	28.8	45°	0.25	1.2	0.69	20.0	24.0	13.50	14.75	4.50	1.75	2.125	4.50	1.845	0.500	3.03	0.375	0.75		
440HP24	58.3	62.8	22.2	28.8	45°	0.25	1.2	0.69	24.0	24.0	13.50	14.75	4.50	1.75	2.125	4.50	1.845	0.500	3.03	0.375	0.75		
440LP16	58.3	62.8	22.2	28.8	45°	0.25	1.2	0.69	16.5	24.0	13.50	14.75	4.50	1.75	2.125	4.50	1.845	0.500	3.03	0.375	0.75		
440LP20	58.3	62.8	22.2	28.8	45°	0.25	1.2	0.69	20.0	24.0	13.50	14.75	4.50	1.75	2.125	4.50	1.845	0.500	3.03	0.375	0.75		
440LP24	58.3	62.8	22.2	28.8	45°	0.25	1.2	0.69	24.0	24.0	13.50	14.75	4.50	1.75	2.125	4.50	1.845	0.500	3.03	0.375	0.75		

CONDUIT BOX DIMENSIONS						MAXIMUM WEIGHT
AA [NPT]	AB	AC	AF	XL	XN	
3.00	20.8	16.5	9.2	15.2	10.3	2500 lbs.

FRAME SIZE	BEARINGS	
	LS	OS
2 POLE HP	6313C3	6314C3
2 POLE LP	6313C3	7314BEGAM x 2
4~8 POLE HP	6318C3	6314C3
4~8 POLE LP	6318C3	7314BEGAM x 2

CUSTOMER: \_\_\_\_\_ MOTOR MODEL NO.: \_\_\_\_\_

P.O. NO.: \_\_\_\_\_ HP: \_\_\_\_\_ VOLTAGE: \_\_\_\_\_ RPM(SYN.): \_\_\_\_\_ Hz: \_\_\_\_\_

FRAME SIZE: \_\_\_\_\_ PRODUCT TYPE: VERTICAL SOLID SHAFT ROUND BODY P-FLANGE

COMMENTS: \_\_\_\_\_

PER: \_\_\_\_\_ DATE: \_\_\_\_\_

TAG NO's: \_\_\_\_\_

STANDARD (NO AUX. BOXES)

RTD AUX. BOX

SPACE HEATER AUX. BOX

BEARING RTD's

TOSHIBA RESERVES THE RIGHT TO MAKE CHANGES OF TECHNICAL IMPROVEMENT AND THE DATA MAY CHANGE WITHOUT NOTICE  PRELIMINARY

DO NOT USE FOR CONSTRUCTION, INSTALLATION, OR APPLICATION PURPOSES UNLESS THE DRAWING IS MARKED AS CERTIFIED  CERTIFIED

**TOSHIBA**

TOSHIBA INTERNATIONAL CORPORATION

TOTALLY-ENCLOSED FAN-COOLED  
VERTICAL SOLID SHAFT ROUND BODY P-FLANGE  
3 PHASE INDUCTION MOTOR  
F1 ASSEMBLY

**XT SERIES**

VISIT OUR WEBSITE AT:  
[www.toshiba.com/ind](http://www.toshiba.com/ind)

**TYPICAL MOTOR PERFORMANCE DATA**

Model: 1506FTVB3RW-A

HP	kW	Pole	FL RPM	Frame	Voltage	Hz	Phase	FL Amps
150	110	6	1185	440HP16	460	60	3	181
Enclosure	IP	Ins. Class	S.F.	Duty	NEMA Nom. Eff.	NEMA Design	kVA Code	Ambient (°C)
TEFC	54	F	1.15	CONT	95.8	B	G	40 C

Load	HP	kW	Amperes	Efficiency (%)	Power Factor (%)
Full Load	150	111.9	181.0	95.8	81.1
¾ Load	112.50	83.9	145.6	96.2	77.7
½ Load	75.00	55.9	112.8	96.1	68.7
¼ Load	37.50	28.0	76.6	90.0	50.9
No Load			64.0		2.7
Locked Rotor			1085.00		34.7

Torque				Rotor wk <sup>2</sup>
Full Load (lb-ft)	Locked Rotor (% FLT)	Pull Up (% FLT)	Break Down (% FLT)	Inertia (lb-ft <sup>2</sup> )
665	220	195	245	78.69

Safe Stall Time(s)		Sound Pressure dB(A) @ 1M	Bearings*		Approx. Motor Weight (lbs)
Cold	Hot		DE	NDE	
23	5	-	6318C3	6314C3	

\*Bearings are the only recommended spare part(s).

**Motor Options:**  
Product Family:EQPIII Vertical Normal Thrust  
Mounting:16 P-Base (280-440 Frame),Shaft:HP Solid Shaft Normal Thrust

Customer	
Customer PO	
Sales Order	
Project #	

Tag:

All characteristics are average expected values.

**TOSHIBA INTERNATIONAL CORPORATION · HOUSTON, TEXAS U.S.A.**

Engineering	gminetos	Doc. Written By	D. Suarez	Doc.# / Rev	MPCF-1119 / 0
Engr. Date	7/25/2013	Doc. Approved By	M. Campbell	Doc. Issued	6/8/2011

Issued Date	8/18/2016	Transmit #	
Issued By	dschoeck	Issued Rev	

**SPEED TORQUE/CURRENT CURVE**

Model: 1506FTVB3RW-A

HP	kW	Pole	FL RPM	Frame	Voltage	Hz	Phase	FL Amps
150	110	6	1185	440HP16	460	60	3	181
Enclosure	IP	Ins. Class	S.F.	Duty	NEMA Nom. Eff.	NEMA Design	kVA Code	Ambient (°C)
TEFC	54	F	1.15	CONT	95.8	B	G	40 C
Locked Rotor Amps	Rotor wk <sup>2</sup> Inertia (lb-ft <sup>2</sup> )	Torque						Break Down (%)
		Full Load (lb-ft)	Locked Rotor (%)	Pull Up (%)				
1085.00	78.69	665	220	195			245	

**Design Values**

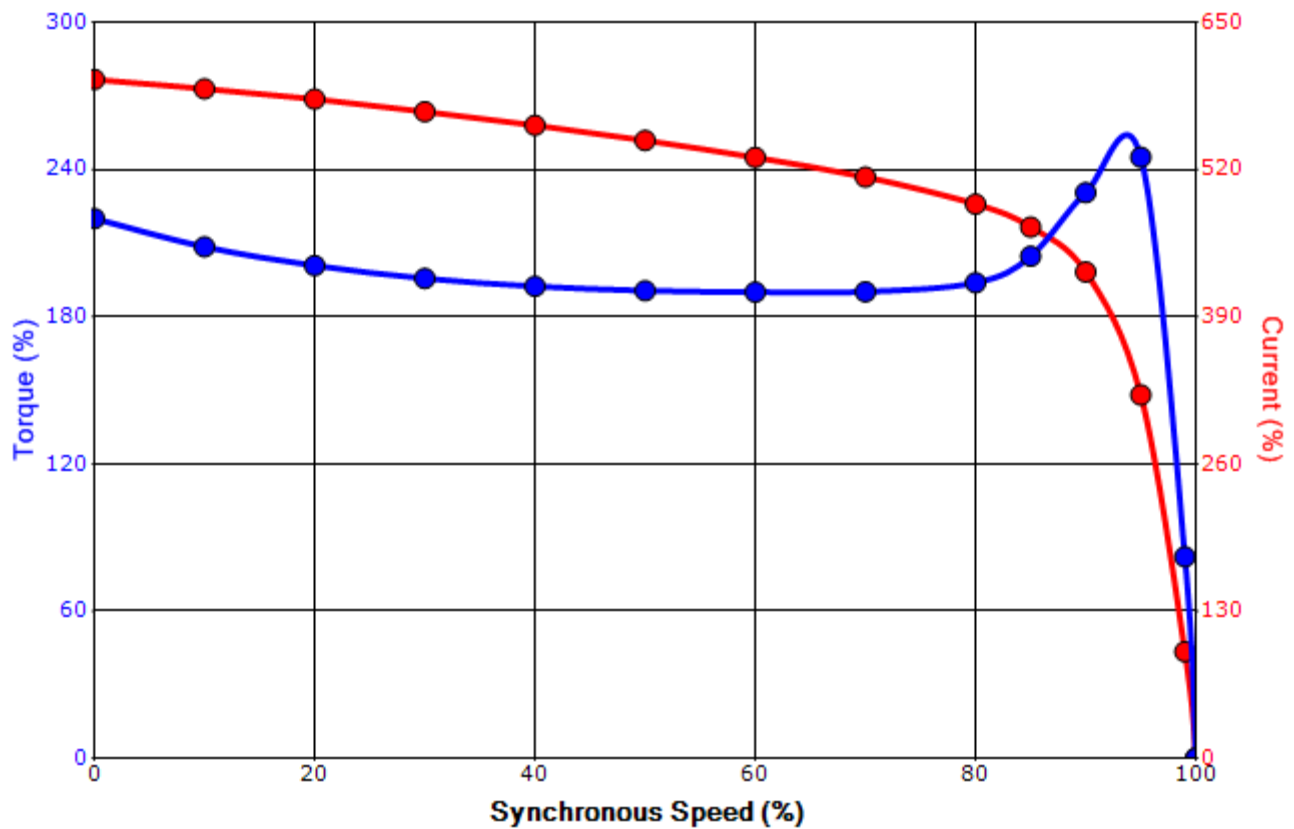

Customer		wk <sup>2</sup> Load Inertia (lb-ft <sup>2</sup> )	-
Customer PO		Load Type	-
Sales Order		Voltage (%)	100
Project #		Accel. Time	-

Tag:

All characteristics are average expected values.

**TOSHIBA INTERNATIONAL CORPORATION · HOUSTON, TEXAS U.S.A.**

Engineering	gminetos	Doc. Written By	D. Suarez	Doc.# / Rev	MPCF-1121 / 0
Engr. Date	7/25/2013	Doc. Approved By	M. Campbell	Doc. Issued	6/8/2011

### Motor Connection Diagram 3 Leads - Delta Connection



Switch L1 and L2 to reverse rotation

Each lead may consist of more than one cable.  
If multiple cables represent a single lead, each one  
of them will be labeled with the appropriate lead number.