

# Hub City™ CleanLine™ Gear Drives

## SS HERA® Gear Drives

### RATINGS

#### SELECT BASIC MODEL

Using the rating chart below, select basic model and ratio based on application HP, service factor and output torque requirements (Please note color-coding for quick selection by motor HP). OR, if interchanging from competitor worm drive, use the interchange chart on page K-32 to select the basic model.

### BASIC MODEL QUICK SELECTION BY MOTOR HP

(1.0 Service Factor @ 1750 RPM Input)

Nom. Ratio	1/2	3/4	1	1-1/2	2	3	5	7-1/2	10	15	20
7/1	35	35	35	35	35	35	45	45			
10/1	35	35	35	35	35	45	45				
15/1	35	35	35	35	35	45	45				
20/1	35	35	35	35	45	45					
30/1	35	35	35	45	45						
40/1	35	35	45	45	45						
50/1	35	45	45	45							
60/1	35	45	45								

Consult factory for high efficiency right angle drives suited for these power ratings.



Try the new HERA® Selector app for Android and iPhone.

### SS HERA® GEAR DRIVE POWER RATINGS (@ 1.0 Service Factor)

Nom. Ratio	INPUT RPM	Eff. (%)	SS HERA35			SS HERA45		
			Exact Ratio	Input HP	Output Torque (in. lbs.)	Exact Ratio	Input HP	Output Torque (in. lbs.)
7/1	2500	90	8.02	2.0	364	7.80	8.5	1504
10/1	2500	90	11.42	2.0	518	11.36	7.5	1933
15/1	2500	90	15.60	2.0	708	15.60	7.0	2478
20/1	2500	90	19.93	2.0	905	19.50	5.9	2600
30/1	2500	90	29.10	1.7	1100	28.01	4.1	2600
40/1	2500	90	43.53	1.1	1100	39.98	2.9	2600
50/1	2500	90	52.50	0.9	1100	52.50	2.2	2600
60/1	2500	90	58.33	0.8	1100	59.79	1.9	2600
7/1	1750	90	8.02	4.2	1100	7.80	8.5	2149
10/1	1750	90	11.42	3.0	1100	11.36	7.1	2600
15/1	1750	90	15.60	2.2	1100	15.60	5.1	2600
20/1	1750	90	19.93	1.7	1100	19.50	4.1	2600
30/1	1750	90	29.10	1.2	1100	28.01	2.9	2600
40/1	1750	90	43.53	0.8	1100	39.98	2.0	2600
50/1	1750	90	52.50	0.7	1100	52.50	1.5	2600
60/1	1750	90	58.33	0.6	1100	59.79	1.3	2600
7/1	1150	90	8.02	2.8	1100	7.80	6.8	2600
10/1	1150	90	11.42	2.0	1100	11.36	4.6	2600
15/1	1150	90	15.60	1.4	1100	15.60	3.4	2600
20/1	1150	90	19.93	1.1	1100	19.50	2.70	2600
30/1	1150	90	29.10	0.8	1100	28.01	1.9	2600
40/1	1150	90	43.53	0.5	1100	39.98	1.3	2600
50/1	1150	90	52.50	0.4	1100	52.50	1.0	2600
60/1	1150	90	58.33	0.4	1100	59.79	0.9	2600
7/1	850	90	8.02	2.1	1100	7.80	5.0	2600
10/1	850	90	11.42	1.4	1100	11.36	3.4	2600
15/1	850	90	15.60	1.1	1100	15.60	2.5	2600
20/1	850	90	19.93	0.8	1100	19.50	2.0	2600
30/1	850	90	29.10	0.6	1100	28.01	1.4	2600
40/1	850	90	43.53	0.4	1100	39.98	1.0	2600
50/1	850	90	52.50	0.3	1100	52.50	0.7	2600
60/1	850	90	58.33	0.3	1100	59.79	0.7	2600
7/1	100	90	8.02	0.2	1100	7.80	0.6	2600
10/1	100	90	11.42	0.2	1100	11.36	0.4	2600
15/1	100	90	15.60	0.1	1100	15.60	0.3	2600
20/1	100	90	19.93	0.1	1100	19.50	0.2	2600
30/1	100	90	29.10	0.07	1100	28.01	0.2	2600
40/1	100	90	43.53	0.04	1100	39.98	0.1	2600
50/1	100	90	52.50	0.04	1100	52.50	0.09	2600
60/1	100	90	58.33	0.03	1100	59.79	0.08	2600

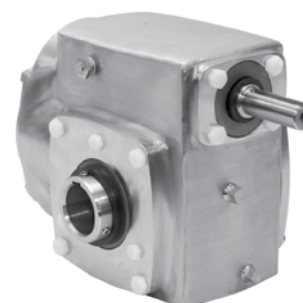
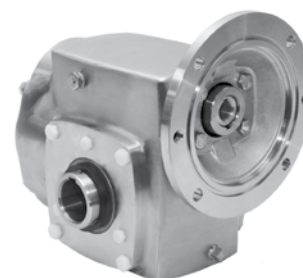

Additional ratios from 70/1 to 420/1 are available by adding a stainless steel helical ratio multiplier to a stainless steel HERA gear drive. See page K-19. All ratios will backdrive due to high efficiency gearing.

# Hub City™ CleanLine™ Gear Drives

## SS HERA® Gear Drives

# COUPLED INPUT

## MODELS: SShERA35PS & SShERA45PS

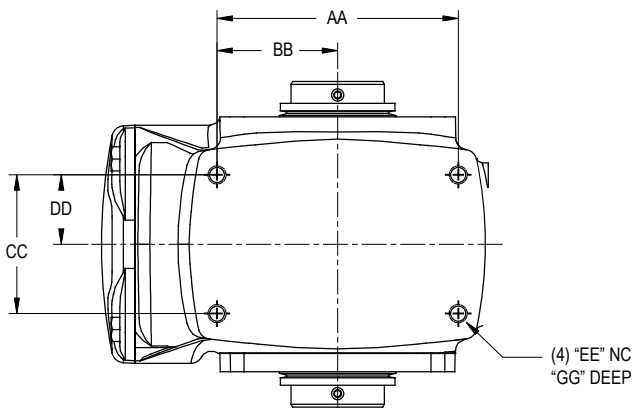
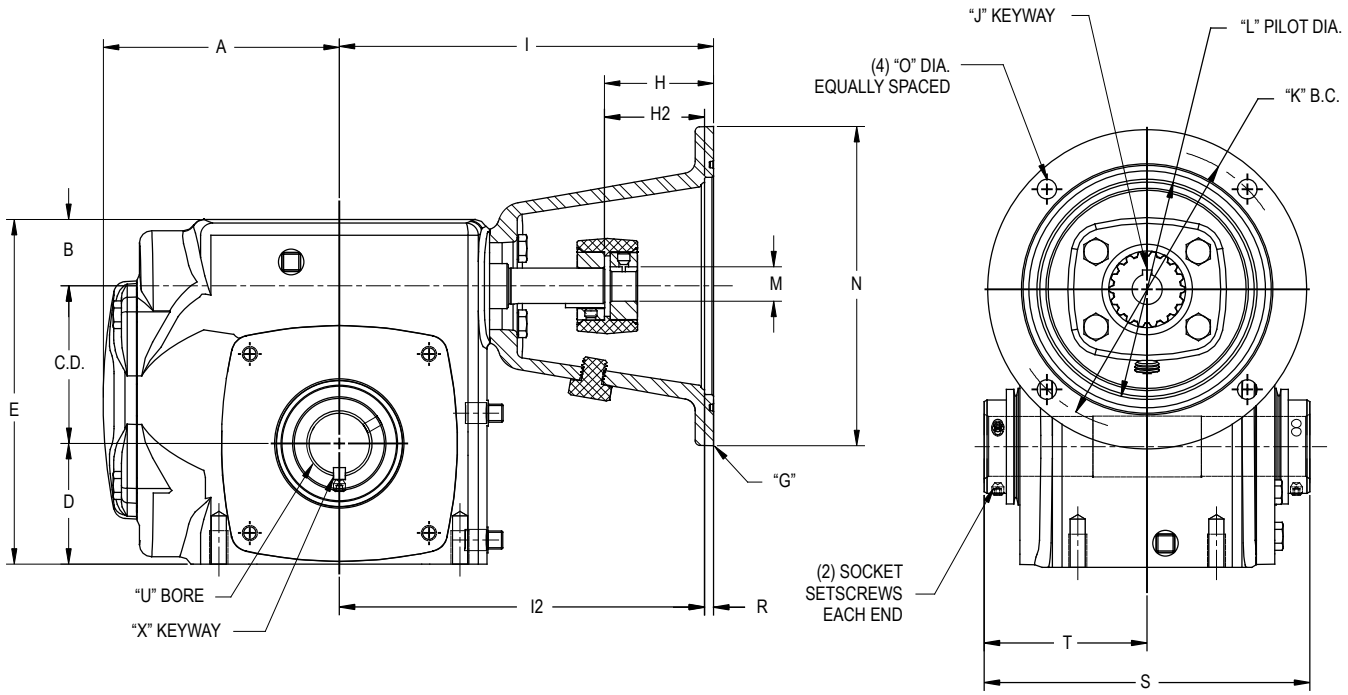

Note: Dual mounting pattern provided on SShERA35

### MODIFIED UNITS ARE AVAILABLE, Consult factory:

These units can be furnished with a solid output shaft on special orders. Stock plug-in shaft kits also available. **SEE PAGE K-28**

Shaft mounted units require torque arms. Torque arm bracket kits are available. **SEE PAGE K-31.**

FOR LUBRICATION AND INSTALLATION INSTRUCTIONS REFER TO SECTION M.

CONSULT FACTORY FOR VERTICAL SHAFT LUBRICATION RECOMMENDATIONS.

INPUT SHAFT CAN BE ROTATED IN EITHER DIRECTION.

DIMENSIONS SHOWN ARE FOR REFERENCE ONLY.

DOWNLOAD AVAILABLE CAD MODELS AT: [WWW.HUBCITYINC.COM](http://WWW.HUBCITYINC.COM)

