

TOL UNLESS SPEC.

2 PLC INCH DEC. =
±.06" [1.5mm]
ANGLES ±0.5°

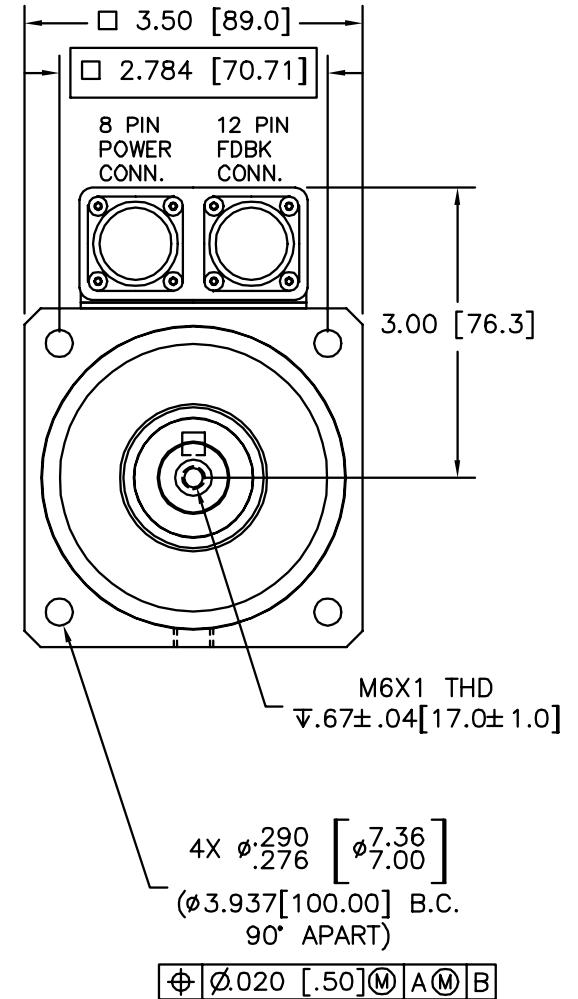
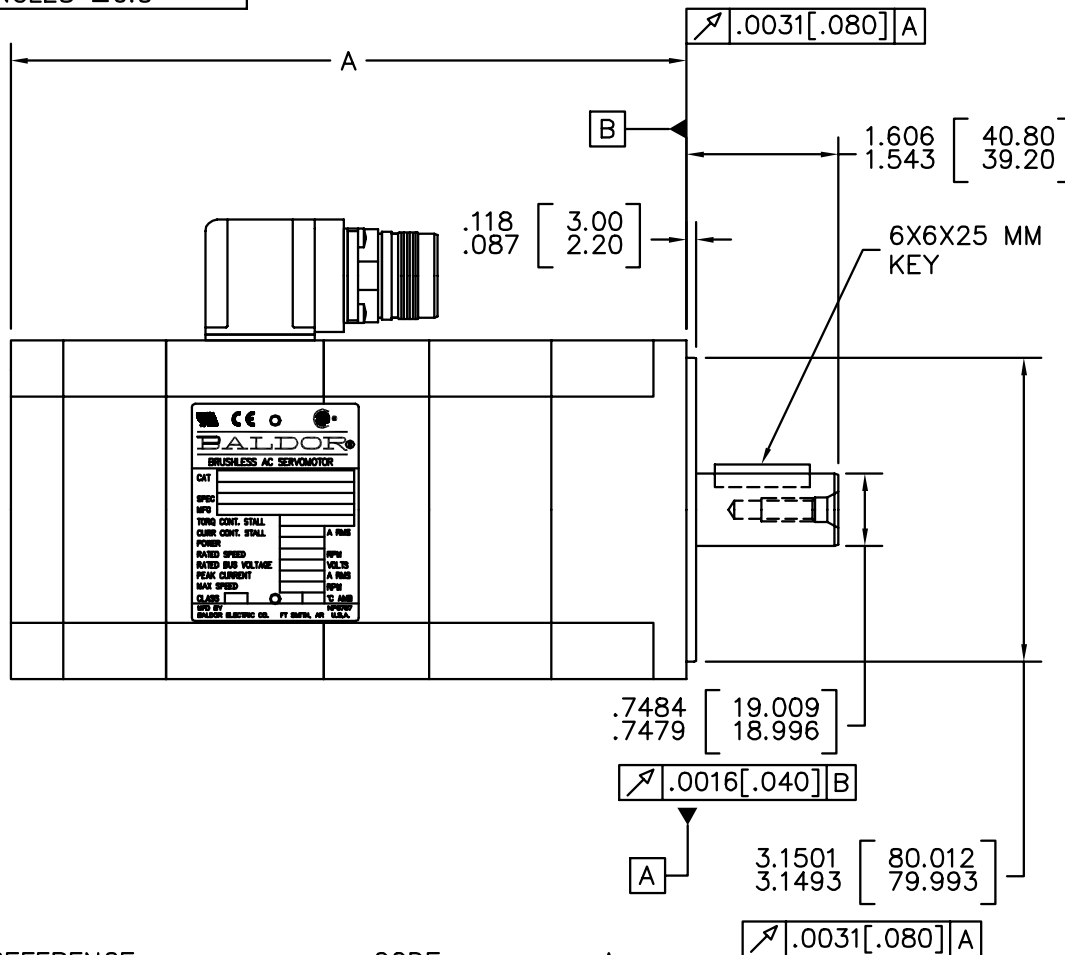

REFERENCE	CODE	A
BSM80A/N-1 & BSM80B-0	10	7.00 [177.9]
BSM80A/N-2 & BSM80B-1	20	8.25 [209.6]
BSM80A/N-3	30	9.50 [241.4]
BSM80B-2	32	9.75 [247.7]
BSM80B-3	44	11.25 [285.8]

CUSTOMER IS RESPONSIBLE FOR DETERMINING THAT MOTOR PERFORMANCE IS SUITABLE IN THE APPLICATION.

REV. DESC: UPDATED REFERENCE			
REV. LTR: C	BY: FN	REVISED: 10:21:11 09/02/2004	TDR: 342291
FILE: AAA00073107		REF: S2LYP117	
MTL: -			

BALDOR ELECTRIC Co.

BSM80, 19D100, BRAKE, RESOLVER, M23 CONNECTORS