

# MCGILL® Inch Cam Follower Bearings

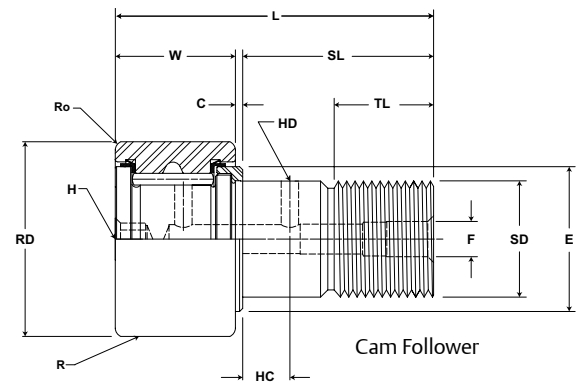

- Basic Construction Type:** Stud Type Crowned / Cylindrical Outside Diameter
- Rolling Elements:** Full Complement Needle Roller
- Bearing Material:** Bearing Quality Steel
- Seal Type:** LUBRI-DISC®
- Lubrication:** Lithium Soap Grease NLGI #2
- System Configuration:** Concentric / Eccentric / Heavy Stud
- Mounting Feature:** Slot / Hex Hole



## CF, CFE, CFH

Part No.		RD		W		SD		SL	C	TL	L	R	ECC	G	BD	Track Roller Dynamic Rating	Track Roller Static Rating
W/O Seals	With LUBRI-DISC Seals	Roller Diameter		Roller Width		Stud Diameter		Stud Length	Endplate Extension	Min Thread Length	Length Overall	Crown Prefix CCF-XX	Eccentric Base Modifier CFE-XX				
		inch mm		inch mm		inch mm		inch mm	inch mm	inch mm	inch mm	inch mm	inch mm				
		Nom.	Tol.	Nom.	Tol.	Nom.	Tol.	(Ref)	(Ref)	(Ref)	(Ref)	Radius (Ref)	(Ref)	+0/-0.010	±.001		
CF 3 1/2	CF 3 1/2 S	3.500 88.90	+0/-0.001 +0/-0.03	2.000 50.80	+0 / - .005 +0 / - .13	1.375 34.93	+0.01/-0 +0.03/-0	2.75 69.9	.031 .8	1.375 34.93	4.78 121.4	Cylindrical	N/A	N/A	N/A	22,800 101,414	31,625 140,668
CF 3 1/2 B	CF 3 1/2 SB											30 762					
CCF 3 1/2	CCF 3 1/2 S																
CCF 3 1/2 B	CCF 3 1/2 SB																
CFE 3 1/2	CFE 3 1/2 S	3.500 88.90	+0/-0.001 +0/-0.03	2.000 50.80	+0 / - .005 +0 / - .13	1.375 34.93	+0.01/-0 +0.03/-0	2.75 69.9	.031 .8	1.375 34.93	4.78 121.4	Cylindrical	.060	1.375	1.812	22,800 101,414	31,625 140,668
CFE 3 1/2 B	CFE 3 1/2 SB											30 762					
CCFE 3 1/2	CCFE 3 1/2 S																
CCFE 3 1/2 B	CCFE 3 1/2 SB																
CFH 3 1/2	CFH 3 1/2 S	3.500 88.90	+0/-0.001 +0/-0.03	2.000 50.80	+0 / - .005 +0 / - .13	1.750 44.45	+0.01/-0 +0.03/-0	2.75 69.9	.031 .8	1.375 34.93	4.78 121.4	Cylindrical	N/A	N/A	N/A	22,800 101,414	63,250 281,336
CFH 3 1/2 B	CFH 3 1/2 SB											30 762					
CCFH 3 1/2	CCFH 3 1/2 S																
CCFH 3 1/2 B	CCFH 3 1/2 SB																
CF 4	CF 4 S	4.000 101.60	+0/-0.001 +0/-0.03	2.250 57.15	+0 / - .005 +0 / - .13	1.500 38.10	+0.01/-0 +0.03/-0	3.50 88.9	.031 .8	1.50 38.1	5.78 146.8	Cylindrical	N/A	N/A	N/A	22,800 101,414	44,770 199,137
CF 4 B	CF 4 SB											30 762					
CCF 4	CCF 4 S																
CCF 4 B	CCF 4 SB																
CFE 4	CFE 4 S	4.000 101.60	+0/-0.001 +0/-0.03	2.250 57.15	+0 / - .005 +0 / - .13	1.500 38.10	+0.01/-0 +0.03/-0	3.50 88.9	.031 .8	1.50 38.1	5.78 146.8	Cylindrical	.060	2.000	2.000	22,800 101,414	44,770 199,137
CFE 4 B	CFE 4 SB											30 762					
CCFE 4	CCFE 4 S																
CCFE 4 B	CCFE 4 SB																
CFH 4	CFH 4 S	4.000 101.60	+0/-0.001 +0/-0.03	2.250 57.15	+0 / - .005 +0 / - .13	2.000 50.80	+0.01/-0 +0.03/-0	3.50 88.9	.031 .8	1.50 38.1	5.78 146.8	Cylindrical	N/A	N/A	N/A	29,985 133,373	89,540 398,274
CFH 4 B	CFH 4 SB											30 762					
CCFH 4	CCFH 4 S																
CCFH 4 B	CCFH 4 SB																

Metric dimensions for reference only.  
Hex wrench size for "Broached" version is located in the wrench size chart on page B-158.

Not all parts are available from stock. Please contact customer service for availability (800) 626-2120.  
For more information on bearing capabilities outside of our standard offering, please contact Application Engineering (800) 626-2093.

# Inch Cam Follower Bearings **McGILL**

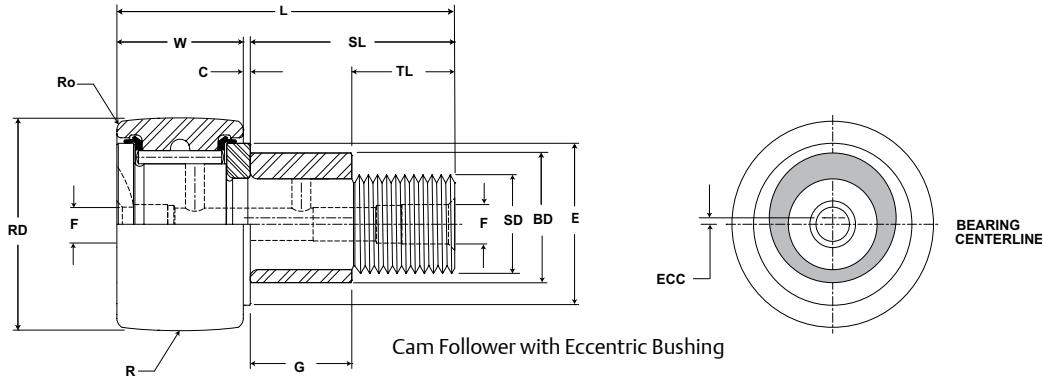

## CF, CFE, CFH

Part No.		HC	HD	F	E	Ro	HBD		Thread Type	Clamping Torque	Limiting Speed (Grease)	WT
W/O Seals	With LUBRI-DISC Seals	Hole Center	Radial Hole Diameter	Axial Hole Dia or Fitting	Min Boss Diameter	Outer Corner	Housing Bore Diameter					
		inch mm		inch mm		inch mm						
		(Ref)	(Ref)	(Ref)	(Ref)	(Ref)	Nom.	Tol.				
CF 3 1/2	CF 3 1/2 S	.6875 17	.125 3	.25 * 6	2.438 61.91	.125 3.18	1.3753	+0.002/-0.003	1 3/8-12	4,200 475	820	6.42 2.91
CF 3 1/2 B	CF 3 1/2 SB					N/A	34.933	+0.005/-0.008				
CCF 3 1/2	CCF 3 1/2 S											
CCF 3 1/2 B	CCF 3 1/2 SB											
CFE 3 1/2	CFE 3 1/2 S	.6875 17	.125 3	.25 * 6	2.438 61.91	.125 3.18	1.815	+0.001/-0.001	1 3/4-12	5,000 565	820	7.01 3.18
CFE 3 1/2 B	CFE 3 1/2 SB					N/A	46.10	+0.025/-0.025				
CCFE 3 1/2	CCFE 3 1/2 S											
CCFE 3 1/2 B	CCFE 3 1/2 SB											
CFH 3 1/2	CFH 3 1/2 S	.6875 17	.125 3	.25 * 6	2.438 61.91	.125 3.18	1.7503	+0.002/-0.003	1 3/4-12	5,000 565	820	9.46 4.29
CFH 3 1/2 B	CFH 3 1/2 SB					N/A	44.458	+0.005/-0.008				
CCFH 3 1/2	CCFH 3 1/2 S											
CCFH 3 1/2 B	CCFH 3 1/2 SB											
CF 4	CF 4 S	.75 19	.125 3	.25 * 6	2.797 71.04	.125 3.18	1.5003	+0.002/-0.003	1 1/2-12	5,000 565	700	10.83 4.91
CF 4 B	CF 4 SB					N/A	38.108	+0.005/-0.008				
CCF 4	CCF 4 S											
CCF 4 B	CCF 4 SB											
CFE 4	CFE 4 S	.75 19	.125 3	.25 * 6	2.797 71.04	.125 3.18	2.002	+0.001/-0.001	2-12	5,000 565	700	10.83 4.91
CFE 4 B	CFE 4 SB					N/A	50.85	+0.025/-0.025				
CCFE 4	CCFE 4 S											
CCFE 4 B	CCFE 4 SB											
CFH 4	CFH 4 S	.75 19	.125 3	.25 * 6	2.797 71.04	.125 3.18	2.0003	+0.002/-0.003	2-12	5,000 565	700	10.83 4.91
CFH 4 B	CFH 4 SB					N/A	50.808	+0.005/-0.008				
CCFH 4	CCFH 4 S											
CCFH 4 B	CCFH 4 SB											

\* Lubrication hole (F) at bottom of hex hole and 1/4 inch straight drive fitting will ball check supplied but not installed.  
 For positive clamping, use housing thickness equal to G dimension  $\pm .010$ ".  
 Clamping torque is based on dry threads. If threads are lubricated, use half of value shown.  
 Hex wrench size for "Broached" version is located in the wrench size chart on page B-158.