

'W' = CLEARANCE ALLOWED FOR ALL VARIANCES
IN MANUFACTURING & ASSEMBLY

SS75180LN

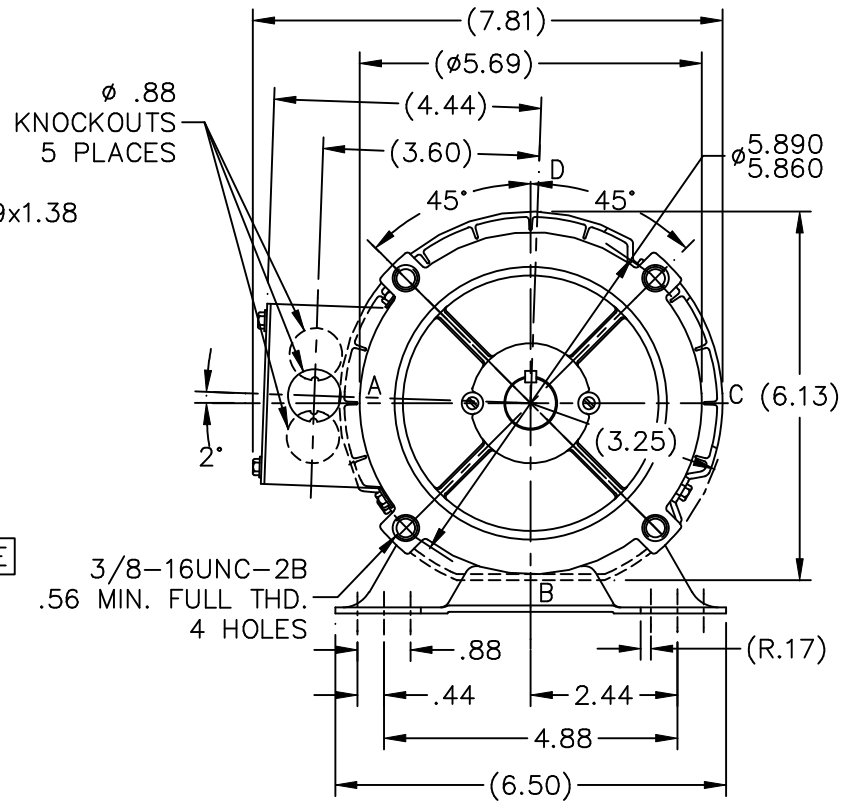
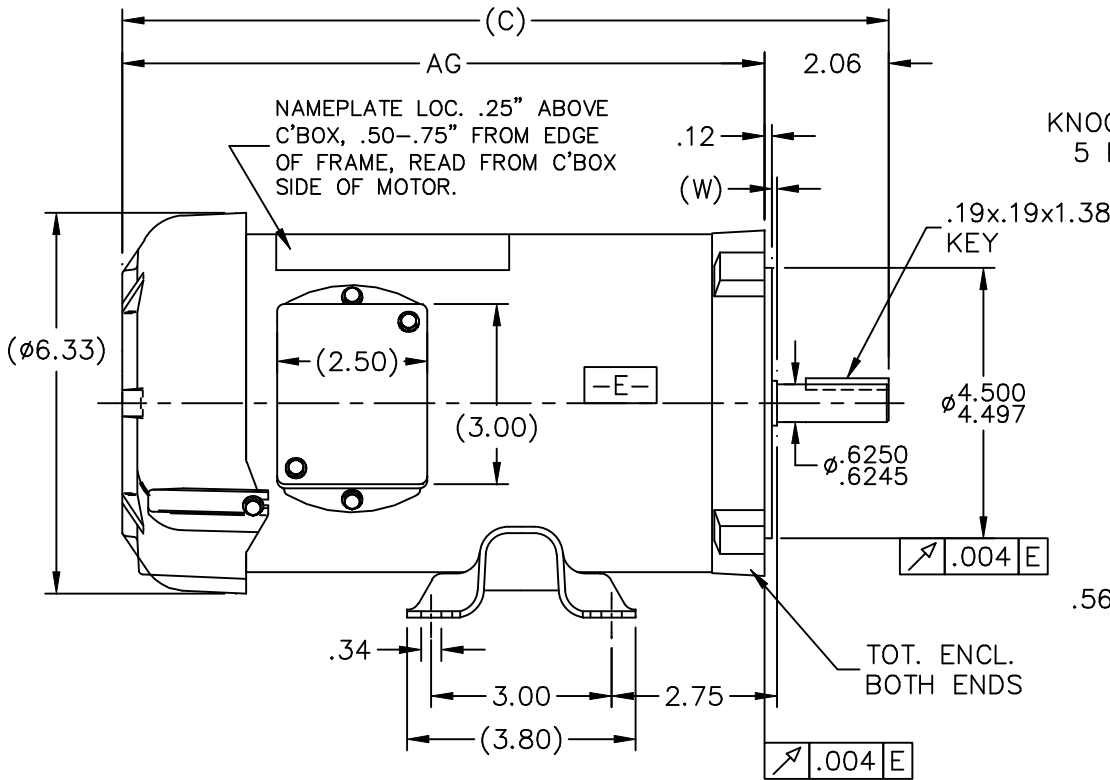

DASH	C	AG	DASH	C	AG
500	9.94	7.88	625	11.19	9.13
525	10.19	8.13	550	10.44	8.38
575	10.69	8.63			

TOLERANCES
UNLESS SPECIFIED

DEC.	INCHES
------	--------

.X	±.1
----	-----

.XX	±.03
-----	------

.XXX	±.005
------	-------

.XXXX	±.0005
-------	--------

ANG	±7'30"
-----	--------



DRAWN BLR 06-11-1999

CHK ML 06-17-1999

APPD GK 06-17-1999

SCALE 5=16

REF

FMF

PREV

TITLE OUTLINE

MAT'L.

FINISH

NO.	REVISION	BY & DATE
1	NEW DRAWING	BLR 06-17-1999

RFP 06-17-1999

DIST WP

CAD FILE ss75180ln

SIZE A

DRAWING NO. SS75180LN PAGE OF 1

REV. 1

THIS DRAWING IN DESIGN AND DETAIL IS OUR PROPERTY AND MUST NOT BE USED EXCEPT IN CONNECTION WITH OUR WORK ALL RIGHTS OF DESIGN AND INVENTION ARE RESERVED THIS IS AN ELECTRONICALLY GENERATED DOCUMENT - DO NOT SCALE THIS PRINT