

HKKChain



12B

British Standard

Superior Capacity Plus

HKK's precision British Standard roller chains are technologically advanced for high strength and low elongation. HKK Superior Capacity Plus® cold-forged solid rollers and solid bushings, is of the highest quality roller chain available. Meets or exceeds ISO standard R606B. The most suitable selection for most any metric application.

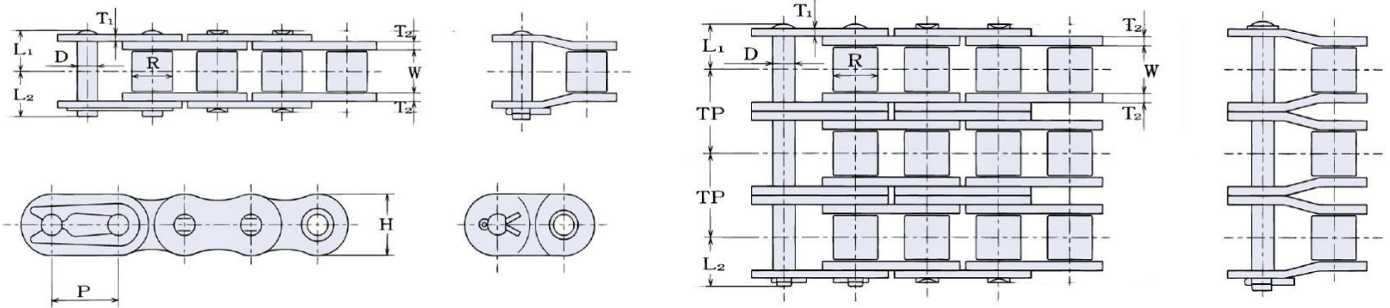

HKK 12B Specifications

HKK Chain Number	Pitch	Roller		Pin Dia. D	Plate			Overall Width		Transverse Pitch G	Maximum Allowable Load (Lbs)	Average Ultimate Strength (Lbs)	Average Weight Per Foot (Lbs)
		Dia. B	Width W		Height H	P/L Thickness T1	R/L Thickness T2	L1	L2				
		A	B		W	D	H	T1	T2				
HKK 12B	3/4	.475	.460	.225	.626	.070	.070	.414	.491	.766	1,585	7,200	.77
HKK 12B-2								.819	.878		2,690	13,700	1.53
HKK 12B-3								1.201	1.256		3,950	20,500	2.26

FEATURES

- Superior Capacity Plus®
- Cold-Forged Solid Bushings
- Wide waist side plates
- Full strength connecting links
- Special alloy pins
- All parts shot peened
- Many other engineered advantages

Other Variations

Aqua-Series II
Stainless Steel

Made in Japan

www.HKKChain.com