

# HKKChain



# 50ss Roller Chain

## 304 Stainless Steel

HKK's precision stainless steel roller chains are manufactured from 300 series stainless steel, to achieve the utmost corrosion and temperature resistance. Equipped with solid rollers which will not split or deform like conventional split rollers under extreme loads and temperatures. Manufactured in accordance with ANSI B29.1 dimensional standards. Manufactured in Japan

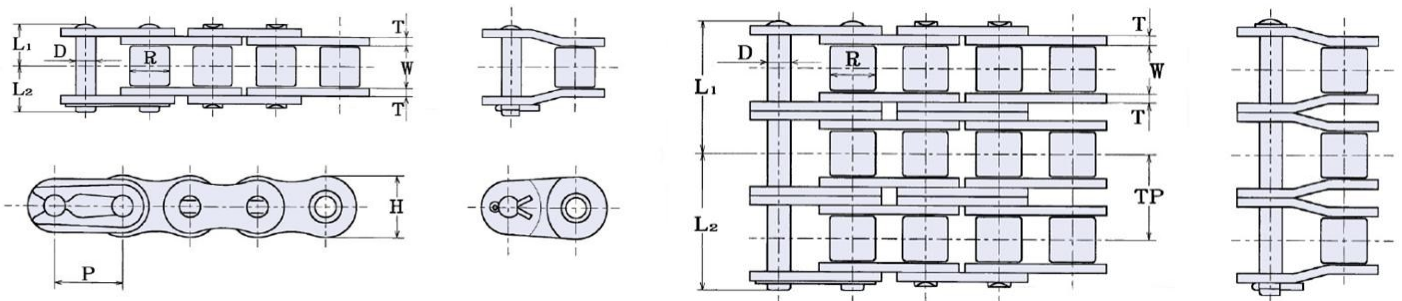

### HKK #50 Stainless Steel Specifications

HKK Chain Number	Pitch A	Roller		Pin	Plate		Overall Width		Transverse G	Maximum Allowable Load (Lbs)	Average Ultimate Strength (Lbs)	Average Weight Per Foot (Lbs)
		Dia.	Width	Dia.	Height	Thickness	L1	L2				
		B	W	D	H	T						
HKK 50 SS	5/8	0.400	3/8	0.200	0.571	0.080	.400	.446	.712	154	4,450	0.67
HKK 50-2 SS							.752	.803		308	8,900	1.36

#### FEATURES

- Made from highly corrosion resistant 304 Stainless Steel
- Solid Rollers
- Recommended for -40°F to 800°F
- All parts shot peened
- Supplied lubrication free

#### Other Variations

- 600 Series Stainless Steel
- Attachments Available

## Made in Japan

[www.HKKChain.com](http://www.HKKChain.com)