

PRODUCT INFORMATION PACKET

Model No: 256TTFL16038
Catalog No: E2124-P
20,1800,TEFC,256T,3/60/230/460
Totally Enclosed Fan Cooled (TEFC)



Regal and Marathon are trademarks of Regal Beloit Corporation or one of its affiliated companies.
©2018 Regal Beloit Corporation, All Rights Reserved. MC017097E





Nameplate Specifications

Output HP	20 Hp	Output KW	14.9 kW
Frequency	60 Hz	Voltage	230/460 V
Current	48/24.1 A	Speed	1775 rpm
Service Factor	1.15	Phase	3
Efficiency	93 %	Duty	CONTINUOUS
Insulation Class	F	Design Code	B
KVA Code	G	Frame	256T
Enclosure	TEFC	Overload Protector	NOT
Ambient Temperature	40 °C	Drive End Bearing Size	6309
Opp Drive End Bearing Size	6208	UL	Recognized
CSA	Y	CE	Y
IP Code	43		

Technical Specifications

Electrical Type	SQ CAGE INV RATED	Starting Method	LINE OR INVERTER
Poles	4	Rotation	REV
Mounting	RIGID	Motor Orientation	HORIZONTAL
Drive End Bearing	BALL	Opp Drive End Bearing	BALL
Frame Material	ALUMINUM	Shaft Type	T
Overall Length	25.26 in	Frame Length	13.75 in
Shaft Diameter	1.63 in	Shaft Extension	4.38 in
Assembly/Box Mounting	F1/F2 CAPABLE		
Outline Drawing	B-SS321100-1375	Connection Diagram	A-EE7308

This is an uncontrolled document once printed or downloaded and is subject to change without notice. Date Created: 04/05/2018

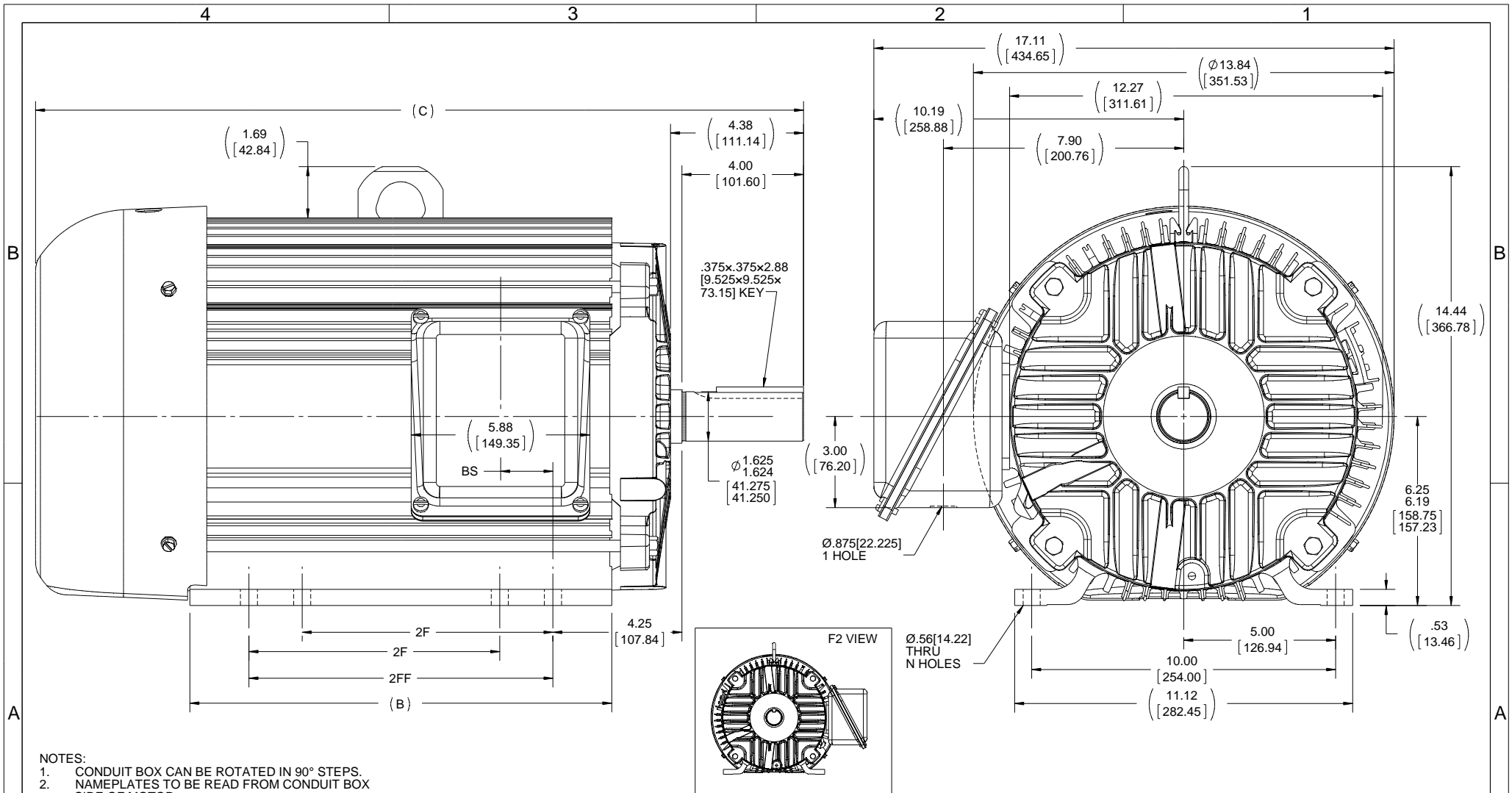

- NOTES:
 1. CONDUIT BOX CAN BE ROTATED IN 90° STEPS.
 2. NAMEPLATES TO BE READ FROM CONDUIT BOX SIDE OF MOTOR.

DASH	FRAME	C	B	2F	2FF	BS	N
1200	254T	23.51 [597.15]	12.13 [308.10]	8.25 [209.55]	-----	1.73 [43.94]	4
1375	254/6T	25.26 [641.60]	13.88 [352.55]	8.25 [209.55]	10.00 [254.00]	1.73 [43.94]	8

DRAWING REVISION C	REVISION BY AJW	DATE 04-16-2015
ECO-0075524	APPROVED BY JHA	DATE 04-16-2015
ECO DESCRIPTION UPDATED TO CURRENT STANDARDS		
<small>COPYRIGHT REGAL BELOIT AMERICA, INC. ALL RIGHTS RESERVED. PROPRIETARY AND CONFIDENTIAL INFORMATION - THIS DOCUMENT IS THE PROPERTY OF REGAL BELOIT AMERICA, INC. (OWNER) AND CONTAINS OWNER'S PROPRIETARY INFORMATION. ANY PERSON, CORPORATION OR OTHER FIRM RECEIVING IT IS DEEMED, BY RECEIVING IT, TO AGREE THAT IT, AND/OR ANY PART OF IT, SHALL NOT BE DISCLOSED TO ANY PERSON, CORPORATION OR OTHER ENTITY, DUPLICATED, AND/OR USED, EXCEPT AS EXPRESSLY APPROVED IN WRITING IN ADVANCE BY OWNER. THIS DOCUMENT SHALL BE RETURNED TO OWNER UPON REQUEST. IT MAY BE SUBJECT TO CERTAIN RESTRICTIONS UNDER APPLICABLE EXPORT CONTROL LAWS AND REGULATIONS.</small>		

TOLERANCES UNLESS OTHERWISE SPECIFIED:			
DEC	INCH	mm	ANGLE
.XX	+0.1	[+2.5]	±7 30°
.XX	±0.03	[±0.76]	
.XXX	±0.005	[±0.127]	
.XXXX	±0.0005	[±0.0127]	
REMOVE BURRS & BREAK SHARP EDGES: .003/.015 [0.076/.381] X 45°			
CORNER FILLETS: R.02 [5.1]			
MACHINED SURFACES: 200 INCH 5.1 mm			
mm SHOWN IN [BRACKETS]			

DRAWN BY RJW	DATE 02-01-2005
APPROVED BY BW	DATE 02-01-2005
REFERENCE	

Regal Beloit America, Inc.	
DESCRIPTION	OUTLINE 250T FR.-ALUM. FR.-TEFC
MATERIAL	PROCESS/FINISH
THIRD ANGLE PROJECTION	SIZE B
DRAWING NUMBER	SS321100
SHEET	1 OF 1

EE7308

THREE PHASE
DUAL VOLTAGE MOTOR



VIEW OF TERMINAL END

REF.
WINDING DIAGRAM

T8Y, T2Y, T2BL, T4BX, T2EC, T2G
T6BZ, T2B, T6BL, T4AV, T6B, T4B

OPTIONAL CORD
CONNECTION

L1 — WHITE
L2 — RED
L3 — BLACK

NO.	REVISION	BY & DATE	CHK	ANG	TOLERANCES UNLESS SPECIFIED		FINISH	DRAWN RM 11/20/1990				
					DEC.	INCHES						
5	CHG TO REGAL LOGO	SL 09/10/2015	AB					CHK ML 11/21/1990				
4	REVISED IEC NOTATIONS	MSG 11/15/2011	CMN	.X	±.1			APPD SAS 04/24/2003				
3	ADDED IEC NOTATIONS... (U1), (V1) ETC. MU95194	MSG 5/10/2010	MJS	.XX	±.02		TITLE CONNECTION DIAGRAM	SCALE 1=1				
2	ADDED THE OPTIONAL CORD CONNECTION MU46318	RDH 04/24/2003	DRS	.XXX	±.005		3Ø - DUAL VOLTAGE MOTOR	REF				
1	REDRAWN	RM 11/20/1990		.XXXX	±.0005		MAT'L.	FMF				
					±7'30"			PREV				
THIS DRAWING IN DESIGN AND DETAIL IS OUR PROPERTY AND MUST NOT BE USED EXCEPT IN CONNECTION WITH OUR WORK ALL RIGHTS OF DESIGN AND INVENTION ARE RESERVED THIS IS AN ELECTRONICALLY GENERATED DOCUMENT - DO NOT SCALE THIS PRINT							RFP	CAD FILE ee7308	SIZE A	DRAWING NO. EE7308	PAGE OF 5	REV. 5
							DIST WP					



CERTIFICATION DATA SHEET

Model#: 256TTFL16038 AN **WINDING#:** K2564164 R26 6
CONN. DIAGRAM: A-EE7308 **ASSEMBLY:** F1/F2 CAPABLE
OUTLINE: B-SS321100-1375

TYPICAL MOTOR PERFORMANCE DATA

HP	KW	SYNC. RPM	F.L. RPM	FRAME	ENCLOSURE	KVA CODE	DESIGN
20&20	14.9&14.9	1800	1775&1450	256T	TEFC	G	B

PH	Hz	VOLTS	FL AMPS	START TYPE	DUTY	INSL	S.F	AMB°C	ELEVATION
3	60/50	230/460#190/ 380	48/24.1&57/28 .5	LINE OR INVERTER	CONTINUOU S	F3	1.15/1.15	40	3300

FULL LOAD EFF: 93&91.7	3/4 LOAD EFF: 93.6	1/2 LOAD EFF: 93	GTD. EFF	ELEC. TYPE	NO LOAD AMPS
			92.4	SQ CAGE INV RATED	17 / 8.5

F.L. TORQUE	LOCKED ROTOR AMPS	L.R. TORQUE	B.D. TORQUE	F.L. RISE°C
59.2 LB-FT	276 / 138	104 LB-FT 176	146 LB-FT 247	65

SOUND PRESSURE @ 3 FT.	SOUND POWER	ROTOR WK^2	MAX. WK^2	SAFE STALL TIME	STARTS /HOUR	APPROX. MOTOR WGT
65 dBA	75 dBA	3.2 LB-FT^2	125 LB-FT^2	25 SEC.	2	425 LBS.

***** SUPPLEMENTAL INFORMATION *****

DE BRACKET TYPE	ODE BRACKET TYPE	MOUNT TYPE	ORIENTATION	SEVERE DUTY	HAZARDOUS LOCATION	DRIP COVER	SCREENS	PAINT
STANDARD	STANDARD	RIGID	HORIZONTAL	FALSE	NONE	FALSE	NONE	BLUE (ENAMEL)

BEARINGS		GREASE	SHAFT TYPE	SPECIAL DE	SPECIAL ODE	SHAFT MATERIAL	FRAME MATERIAL
DE	OPE	POLYREX EM	T	NONE	NONE	1045 HOT ROLLED (C-204)	ALUMINUM
BALL	BALL						
6309	6208						

THERMO-PROTECTORS				THERMISTORS	CONTROL	SPACE /n HEATERS
THERMOSTATS	PROTECTORS	WDG RTDs	BRG RTDs	NONE	FALSE	NONE VOLTS
NONE	NOT	NONE	NONE			

If Inverter equals NONE, contact factory for further information

*
N
O
T
E
S
*

INVERTER TORQUE: CONSTANT 10:1 INV. HP SPEED RANGE: NONE
ENCODER: NONE NONE NONE NONE NONE PPR
BRAKE: NONE NONE NONE P/N NONE NONE NONE - FT-LB NONE V NONE Hz

DATE: 06/21/2017 10:43:30 AM
 FORM 3531 REV.3 02/07/99
 ** Subject to change without notice.