

DUTY MASTER ALTERNATING CURRENT MOTORS

SQUIRREL-CAGE INDUCTION

ENCLOSURE: TOTALLY ENCLOSED
MOUNTING: FOOT

FRAME G445T ABOVE NEMA RATINGS
INCLUDES 444T FRAME MOUNTING HOLES

COOLING: FAN COOLED
841XL ENCLOSURE ENHANCEMENT

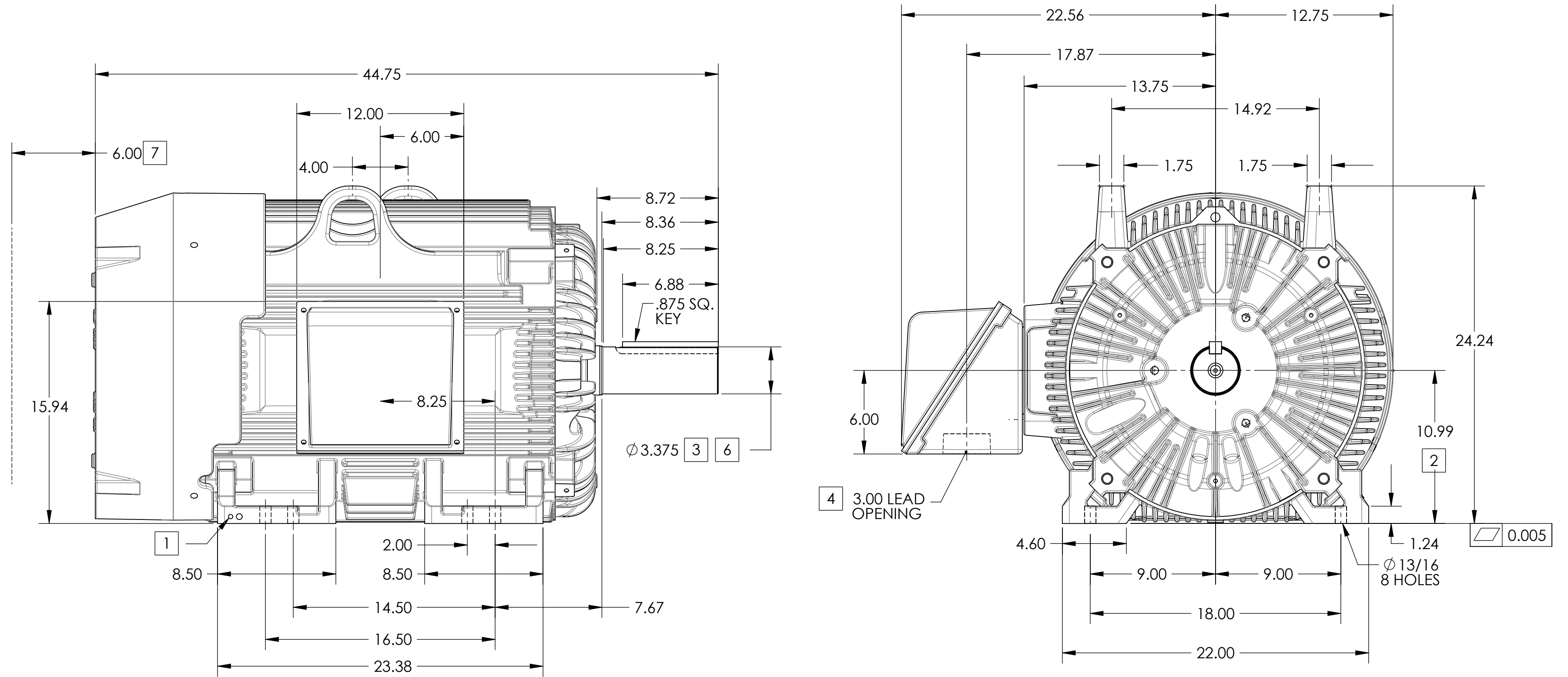

1. GROUND HOLES QTY 1 1/2-13 TAP; QTY 1 3/8-16 TAP
2. VARIES +.00,-.06
3. VARIES +.000,-.001
4. ON STANDARD MOTORS THIS IS CONDUIT SIZE. ON XT AND CORROSION PROOF MOTOR THIS IS PIPE TAP.
5. MOTOR WEIGHTS MAY VARY BY 15% DEPENDING ON RATING.
6. SHAFT TIR = 0.0015 IN FOR BALL BEARING MOTORS AND 0.002 IN FOR ROLLER BEARING CONSTRUCTION
7. OBSTRUCTION MUST NO ENCROACH ON AIR INLET

5 WEIGHT (LBS): 2130

DRIVE END AIR DEFLECTOR IS ONLY INCLUDED WHEN NECESSARY.

DIMENSIONS ARE IN INCHES; SEE SHEET 2 FOR DIMENSIONS IN MILLIMETERS

CUSTOMER IS RESPONSIBLE FOR DETERMINING THAT MOTOR PERFORMANCE IS SUITABLE IN THE APPLICATION.

CONDUIT BOX LOCATED ON OPPOSITE SIDE WHEN F-2.
IF MOUNTING CLEARANCE DETAILS ARE REQUIRED, CONSULT FACTORY.
MAXIMUM PERMISSIBLE SHAFT RUNOUT WHEN MEASURED AT END OF STANDARD SHAFT EXTENSION IS .003" T.I.R. TO 5 INCH DIA.

REV. DESC: CHANGE C/BOX TO 076863-000C			
REV: D	VERSION: 04	REVISED: 10:17:59 09/25/2015	TDR: 000000945832
MODEL NO. 617427-061		REF:	
BY: RAGJSS1	Material:	C	

DUTY MASTER ALTERNATING CURRENT MOTORS

SQUIRREL-CAGE INDUCTION

ENCLOSURE: TOTALLY ENCLOSED
MOUNTING: FOOT

FRAME G445T ABOVE NEMA RATINGS
INCLUDES 444T FRAME MOUNTING HOLES

COOLING: FAN COOLED
841XL ENCLOSURE ENHANCEMENT

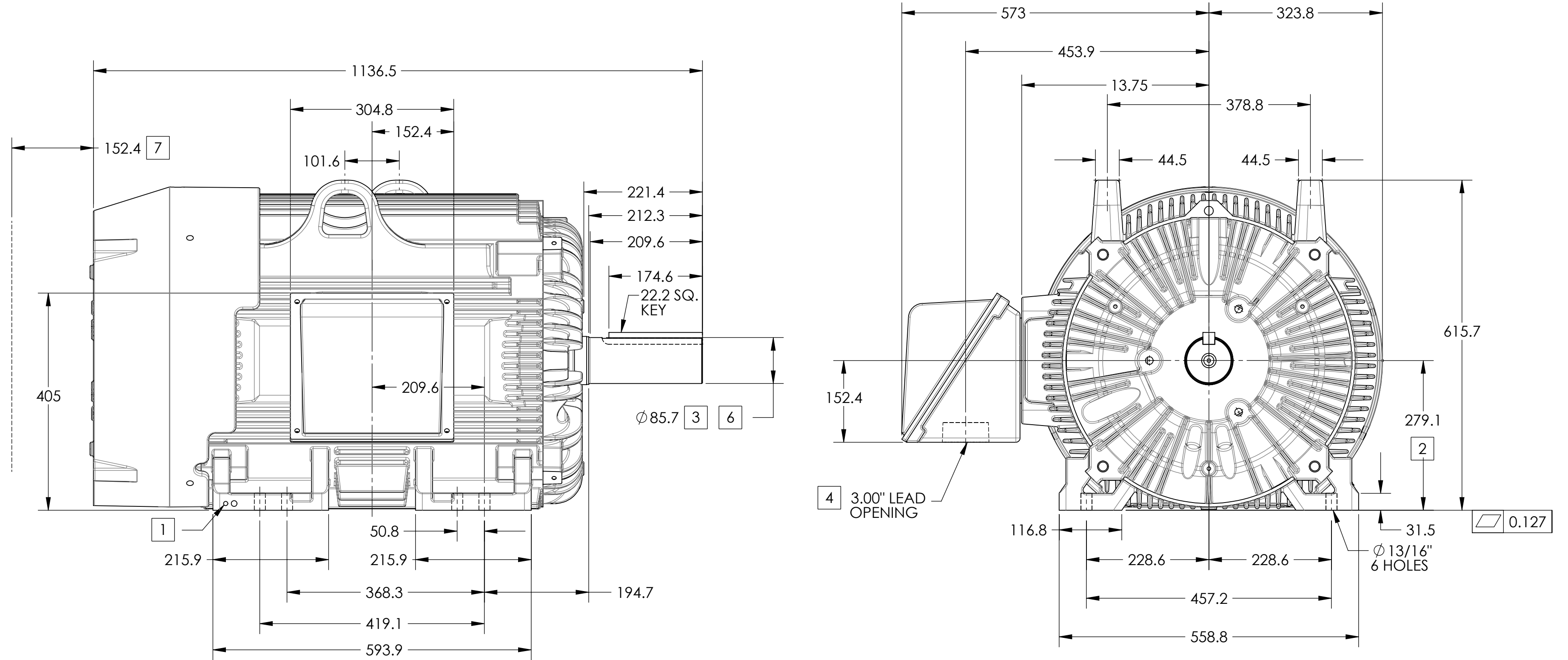

1. GROUND HOLES QTY 1 1/2-13 TAP; QTY 1 3/8-16 TAP
2. VARIES +.00,-1.52MM
3. VARIES +.000,-.025MM
4. ON STANDARD MOTORS THIS IS CONDUIT SIZE. ON XT AND CORROSION PROOF MOTOR THIS IS PIPE TAP.
5. MOTOR WEIGHTS MAY VARY BY 15% DEPENDING ON RATING.
6. SHAFT TIR = 0.038MM FOR BALL BEARING MOTORS AND 0.051 MM FOR ROLLER BEARING CONSTRUCTION
7. OBSTRUCTION MUST NO ENCROACH ON AIR INLET

5 WEIGHT (KGS): 970

DRIVE END AIR DEFLECTOR IS ONLY INCLUDED WHEN NECESSARY.

DIMENSIONS ARE IN MILLIMETERS; SEE SHEET 1 FOR DIMENSIONS IN INCHES

CUSTOMER IS RESPONSIBLE FOR DETERMINING THAT MOTOR PERFORMANCE IS SUITABLE IN THE APPLICATION.

CONDUIT BOX LOCATED ON OPPOSITE SIDE WHEN F-2.
IF MOUNTING CLEARANCE DETAILS ARE REQUIRED, CONSULT FACTORY.
MAXIMUM PERMISSIBLE SHAFT RUNOUT WHEN MEASURED AT END OF STANDARD SHAFT EXTENSION IS .08 MM T.I.R. TO 127 MM DIA.

REV. DESC: CHANGE C/BOX TO 076863-000C			
REV: D	VERSION: 04	REVISED: 10:17:59 09/25/2015	TDR: 000000945832
MODEL NO. 617427-061		REF:	
BY: RAGJSS1	Material:	C	

BALDOR

G445T/444T STD - FOOTED - SIDE/CENTER C/B - 841XL