

TERM. END

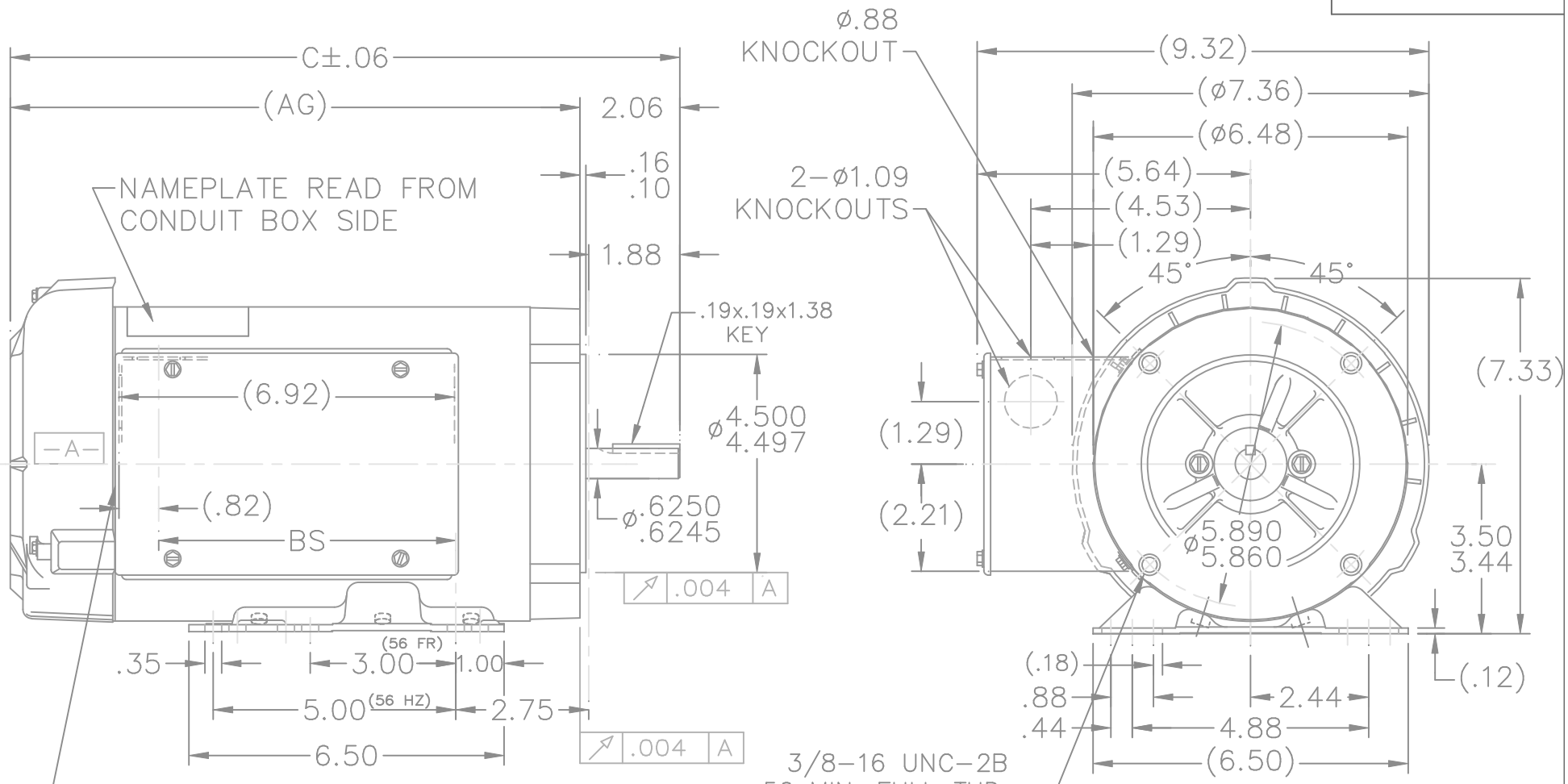

NOTES:
1. BASE IS REMOVEABLE

DASH	FRAME	C	AG	BS
806	56.80	13.31	11.25	5.63
856	"-75	13.81	11.75	6.13
906	"-80	14.31	12.25	6.63
956	"-85	14.81	12.75	7.13

		TOLERANCES UNLESS SPECIFIED		MARATHON ELECTRIC		DRAWN BLR 05-27-1997		
		DEC.	INCHES	TITLE OUTLINE		CHK ML 06-03-1997		
		.X	±.1	56 FR. - BB - TEFC - 1 ϕ - C"FACE <td colspan="2">APPD GK 06-03-1997</td>		APPD GK 06-03-1997		
		.XX	±.03	MAT'L.		SCALE 5=16		
		.XXX	±.005	FINISH		REF		
3	REDRAWN ON CAD	BLR 06-03-1997	.XXXX	±.0005			FMF	
NO.	REVISION	BY & DATE	CHK	ANG	±'30"	PREV		
THIS DRAWING IN DESIGN AND DETAIL IS OUR PROPERTY AND MUST NOT BE USED EXCEPT IN CONNECTION WITH OUR WORK ALL RIGHTS OF DESIGN AND INVENTION ARE RESERVED THIS IS AN ELECTRONICALLY GENERATED DOCUMENT - DO NOT SCALE THIS PRINT		RFP	CAD FILE 100144		SIZE	DRAWING NO.	PAGE OF	REV.
		DIST WP			A	100144		3