

PRODUCT INFORMATION PACKET

Model No: 143TTDR16048
Catalog No: GT2401
1,1800,DP,143JPV,3/60/230/460
JP



Regal and Marathon are trademarks of Regal Beloit Corporation or one of its affiliated companies.
©2018 Regal Beloit Corporation, All Rights Reserved. MC017097E





Nameplate Specifications

Output HP	1 Hp	Output KW	0.75 kW
Frequency	60 Hz	Voltage	230/460 V
Current	3/1.5 A	Speed	1760 rpm
Service Factor	1.15	Phase	3
Efficiency	85.5 %	Duty	CONTINUOUS
Insulation Class	F	Design Code	B
KVA Code	N	Frame	143JP
Enclosure	DP	Overload Protector	NOT
Ambient Temperature	40 °C	Drive End Bearing Size	6206
Opp Drive End Bearing Size	6203	UL	Recognized
CSA	Y	CE	Y
IP Code	22		

Technical Specifications

Electrical Type	SQ CAGE INV RATED	Starting Method	LINE OR INVERTER
Poles	4	Rotation	REV
Mounting	RIGID	Motor Orientation	HORIZONTAL
Drive End Bearing	BALL	Opp Drive End Bearing	BALL
Frame Material	ROLLED STEEL	Shaft Type	JP
Overall Length	18.18 in	Frame Length	9.06 in
Shaft Diameter	0.88 in	Shaft Extension	7.31 in
Assembly/Box Mounting	F1 ONLY		
Outline Drawing	A-100132-906	Connection Diagram	A-EE7308

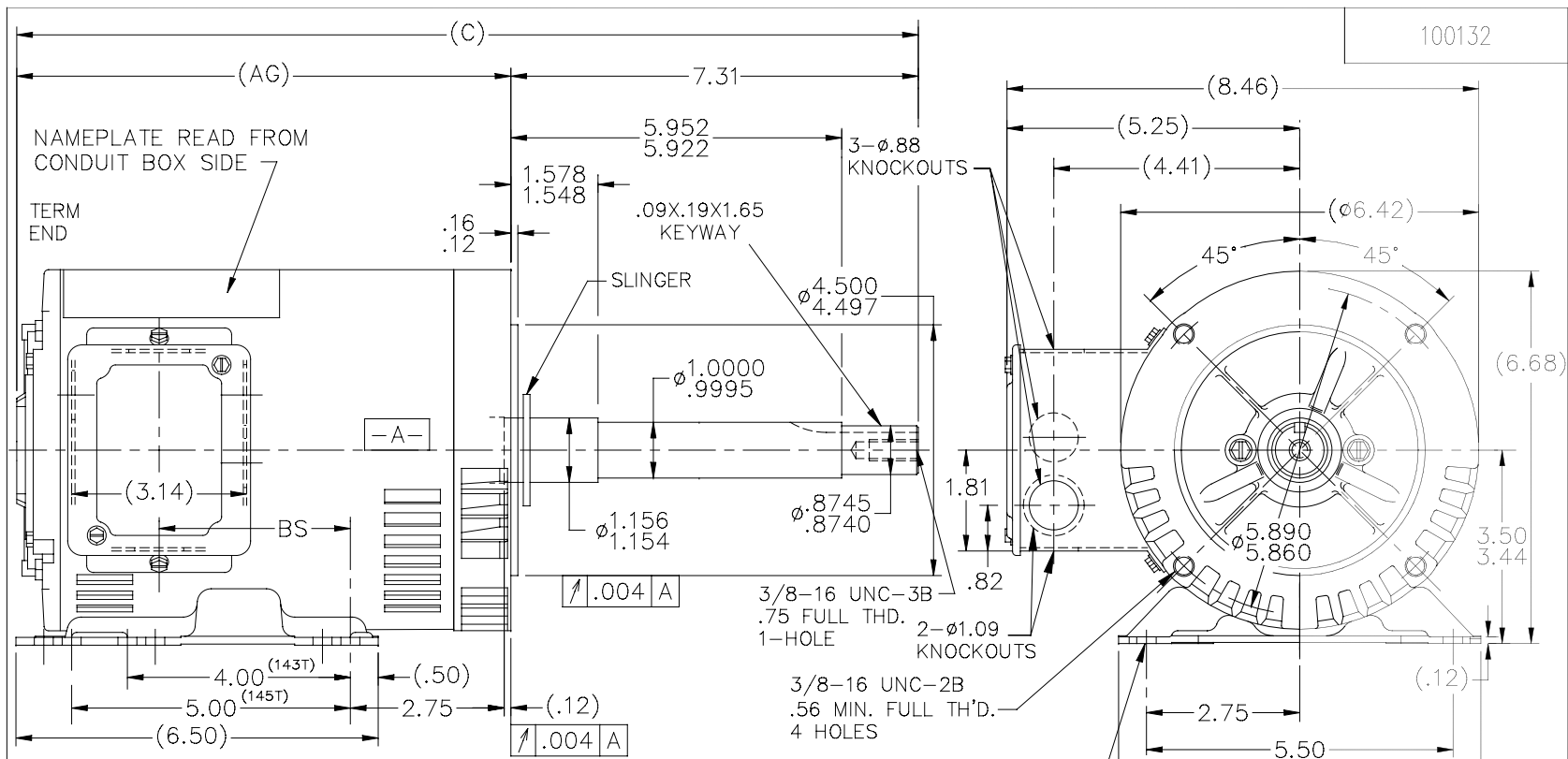

DASH	FR.	C	AG	BS	DASH	FR.	C	AG	BS
					806	140T	17.18	9.87	4.37
					856	140T	17.68	10.37	4.87
706	140T	16.18	8.87	3.37	906	140T	18.18	10.87	5.37
756	140T	16.68	9.37	3.87	956	140T	18.68	11.37	5.87

NO.	REVISION	BY & DATE	CHK	ANG	TOLERANCES UNLESS SPECIFIED		FINISH
					DEC.	INCHES	
9	CHANGED LOGO TO REGAL	SL 09-14-2015	AB	.XX	±.03		
8	REDRAWN IN AUTOCAD	TAT 07-13-2004	ML	.XXX	±.005		
7	REDRAWN ON CADD	BRH 11-06-1995		.XXXX	±.0005		
					±'.30"		

REGAL™ Regal Beloit America, Inc.

TITLE OUTLINE
140 FR.-BB-DR.PR.-3ø-C' FACE-JP EXT.

DRAWN BRH 11-02-1995
CHK DA 11-06-1995
APPD GK 11-06-1995

SCALE 3=8
REF
FMF
PREV

THIS DRAWING IN DESIGN AND DETAIL IS OUR PROPERTY AND MUST NOT BE USED EXCEPT IN CONNECTION WITH OUR WORK ALL RIGHTS OF DESIGN AND INVENTION ARE RESERVED THIS IS AN ELECTRONICALLY GENERATED DOCUMENT - DO NOT SCALE THIS PRINT

RFP
DIST WP

CAD FILE 100132

SIZE A
DRAWING NO. 100132
PAGE 3 OF 8
REV. 9

EE7308

THREE PHASE
DUAL VOLTAGE MOTOR



VIEW OF TERMINAL END

REF.
WINDING DIAGRAM

T8Y, T2Y, T2BL, T4BX, T2EC, T2G
T6BZ, T2B, T6BL, T4AV, T6B, T4B

OPTIONAL CORD
CONNECTION

L1 — WHITE
L2 — RED
L3 — BLACK

NO.	REVISION	BY & DATE	CHK	ANG	TOLERANCES UNLESS SPECIFIED		FINISH	DRAWN RM 11/20/1990				
					DEC.	INCHES						
5	CHG TO REGAL LOGO	SL 09/10/2015	AB					CHK ML 11/21/1990				
4	REVISED IEC NOTATIONS	MSG 11/15/2011	CMN	.X	±.1			APPD SAS 04/24/2003				
3	ADDED IEC NOTATIONS... (U1), (V1) ETC. MU95194	MSG 5/10/2010	MJS	.XX	±.02			SCALE 1=1				
2	ADDED THE OPTIONAL CORD CONNECTION MU46318	RDH 04/24/2003	DRS	.XXX	±.005		TITLE CONNECTION DIAGRAM 3Ø - DUAL VOLTAGE MOTOR	REF				
1	REDRAWN	RM 11/20/1990		.XXXX	±.0005		MAT'L.	FMF				
					±7'30"			PREV				
THIS DRAWING IN DESIGN AND DETAIL IS OUR PROPERTY AND MUST NOT BE USED EXCEPT IN CONNECTION WITH OUR WORK ALL RIGHTS OF DESIGN AND INVENTION ARE RESERVED THIS IS AN ELECTRONICALLY GENERATED DOCUMENT - DO NOT SCALE THIS PRINT							RFP	CAD FILE ee7308	SIZE A	DRAWING NO. EE7308	PAGE OF 5	REV. 5
							DIST WP					



CERTIFICATION DATA SHEET

Model#: 143TTDR16048 AA **WINDING#:** ZT4259 NONE 3
CONN. DIAGRAM: A-EE7308 **ASSEMBLY:** F1 ONLY
OUTLINE: A-100132-906

TYPICAL MOTOR PERFORMANCE DATA

HP	KW	SYNC. RPM	F.L. RPM	FRAME	ENCLOSURE	KVA CODE	DESIGN
1 3/4	.75&.56	1800	1760&1460	143JP	DP	N	B

PH	Hz	VOLTS	FL AMPS	START TYPE	DUTY	INSL	S.F	AMB°C	ELEVATION
3	60/50	230/460#190/ 380	3/1.5&3/1.5	LINE OR INVERTER	CONTINUOU S	F3	1.15/1.0	40	3300

FULL LOAD EFF: 85.5&85.3	3/4 LOAD EFF: 84.6	1/2 LOAD EFF: 81.3	GTD. EFF	ELEC. TYPE	NO LOAD AMPS
FULL LOAD PF: 71&69.3	3/4 LOAD PF: 62.6	1/2 LOAD PF: 49.8	82.5	SQ CAGE INV RATED	2 / 1

F.L. TORQUE	LOCKED ROTOR AMPS	L.R. TORQUE	B.D. TORQUE	F.L. RISE°C
3 LB-FT	29 / 14.5	11.2 LB-FT 373	15.4 LB-FT 513	21

SOUND PRESSURE @ 3 FT.	SOUND POWER	ROTOR WK^2	MAX. WK^2	SAFE STALL TIME	STARTS /HOUR	APPROX. MOTOR WGT
56 dBA	66 dBA	0.117 LB-FT^2	10 LB-FT^2	20 SEC.	2	0 LBS.

***** SUPPLEMENTAL INFORMATION *****

DE BRACKET TYPE	ODE BRACKET TYPE	MOUNT TYPE	ORIENTATION	SEVERE DUTY	HAZARDOUS LOCATION	DRIP COVER	SCREENS	PAINT
C-FACE	STANDARD	RIGID	HORIZONTAL	FALSE	NONE	PROVISIONS ONLY	NONE	BLUE (POWDER)

BEARINGS		GREASE	SHAFT TYPE	SPECIAL DE	SPECIAL ODE	SHAFT MATERIAL	FRAME MATERIAL
DE	OPE						
BALL	BALL	POLYREX EM	JP	NONE	NONE	1144 STRESSPROOF (C-223)	ROLLED STEEL
6206	6203						

THERMO-PROTECTORS				THERMISTORS	CONTROL	SPACE /n HEATERS
THERMOSTATS	PROTECTORS	WDG RTDs	BRG RTDs			
NONE	NOT	NONE	NONE	NONE	FALSE	NONE VOLTS

If Inverter equals NONE, contact factory for further information

*
N
O
T
E
S
*

INVERTER TORQUE: CONSTANT 2:1 INV. HP SPEED RANGE: NONE
ENCODER: NONE NONE NONE NONE NONE PPR
BRAKE: NONE NONE NONE P/N NONE NONE NONE - FT-LB NONE V NONE Hz

DATE: 06/22/2017 07:33:17 AM
 FORM 3531 REV.3 02/07/99

** Subject to change without notice.

Data Sheet

Date: 20-06-2017
 Customer: _____
 Attention: _____
 Submitted by: FAREEDA DUDEKULA



143TTDR16048

Submittal

Data @ 460 V

Motor Load Data

Load	0%	25%	50%	75%	100%	115%	125%	LR
Current (Amps)	0.98	1.03	1.15	1.32	1.50	1.67	1.77	14.5
Torque (ft-lb)	0.00	0.73	1.47	2.22	3.0	3.4	3.7	11.2
RPM	1800	1790	1781	1772	1760	1,755	1751	0
Efficiency (%)		71.3	81.3	84.6	85.5	85.7	85.5	
P.F. (%)	11.1	31.8	49.8	62.6	71.0	75.1	77.3	73.4

Motor Speed Data

	LR	Pull-Up	BD	Rated	Idle
Speed (RPM)	0	120	1285	1760	1800
Current (Amps)	14.5	13.0	9.8	1.50	0.98
Torque (ft-lb)	11.2	10.0	15.4	3.0	0.00

Information Block

HP	1.0			
Sync. RPM	1800			
Frame	143			
Enclosure	DP			
Construction	TDR			
Voltage	30/460#190/38V			
Frequency	60 Hz			
Design	A			
LR Code letter	N			
Service Factor	1.15			
Temp Rise @ FL	21 ° C			
Duty	CONT			
Ambient	40 ° C			
Elevation	1,000 feet			
Rotor/Shaft wk ²	0.12 Lb-Ft ²			
Ref Wdg	ZT4259 NONE			
Sound Pressure @ 1M	56 dBA			
VFD Rating	CONSTANT 2:1			
Outline Dwg	A-100132-906			
Conn. Diag	A-EE7308			
Additional Specifications:				
0				
365THFS8036				
EQUIV CKT (OHMS / PHASE)				
R1	R2	X1	X2	Xm
0.0000	0.0000	0.0000	0.0000	0.0000

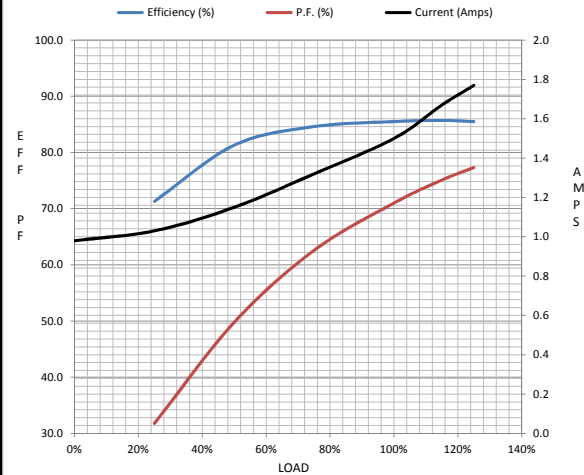

Speed -Torque Curve

