

# PRODUCT INFORMATION PACKET

Model No: 145TTDR6034  
Catalog No: GT0404  
1 1/2,1800,DP,145JM,3/60/230/460  
JM

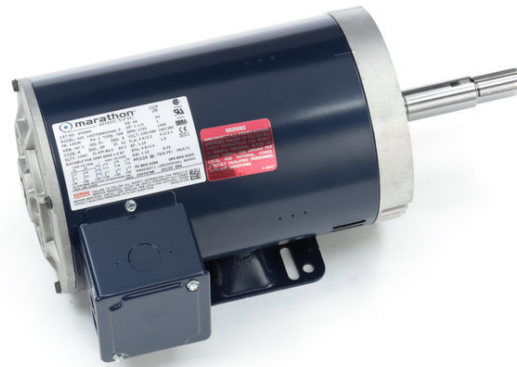

Regal and Marathon are trademarks of Regal Beloit Corporation or one of its affiliated companies.  
©2018 Regal Beloit Corporation, All Rights Reserved. MC017097E





### Nameplate Specifications

Output HP	1.5 Hp	Output KW	1.12 kW
Frequency	60 Hz	Voltage	230/460 V
Current	4.4/2.2 A	Speed	1755 rpm
Service Factor	1.15	Phase	3
Efficiency	86.5 %	Duty	CONTINUOUS
Insulation Class	F	Design Code	B
KVA Code	M	Frame	145JM
Enclosure	DP	Overload Protector	NOT
Ambient Temperature	40 °C	Drive End Bearing Size	6206
Opp Drive End Bearing Size	6203	UL	Recognized
CSA	Y	CE	Y
IP Code	22		

### Technical Specifications

Electrical Type	SQ CAGE INV RATED	Starting Method	LINE OR INVERTER
Poles	4	Rotation	REV
Mounting	RIGID	Motor Orientation	HORIZONTAL
Drive End Bearing	BALL	Opp Drive End Bearing	BALL
Frame Material	ROLLED STEEL	Shaft Type	JM
Overall Length	15.12 in	Frame Length	9.06 in
Shaft Diameter	0.88 in	Shaft Extension	4.25 in
Assembly/Box Mounting	F1 ONLY		
Outline Drawing	A-100130-906	Connection Diagram	A-EE7308

This is an uncontrolled document once printed or downloaded and is subject to change without notice. Date Created: 04/05/2018

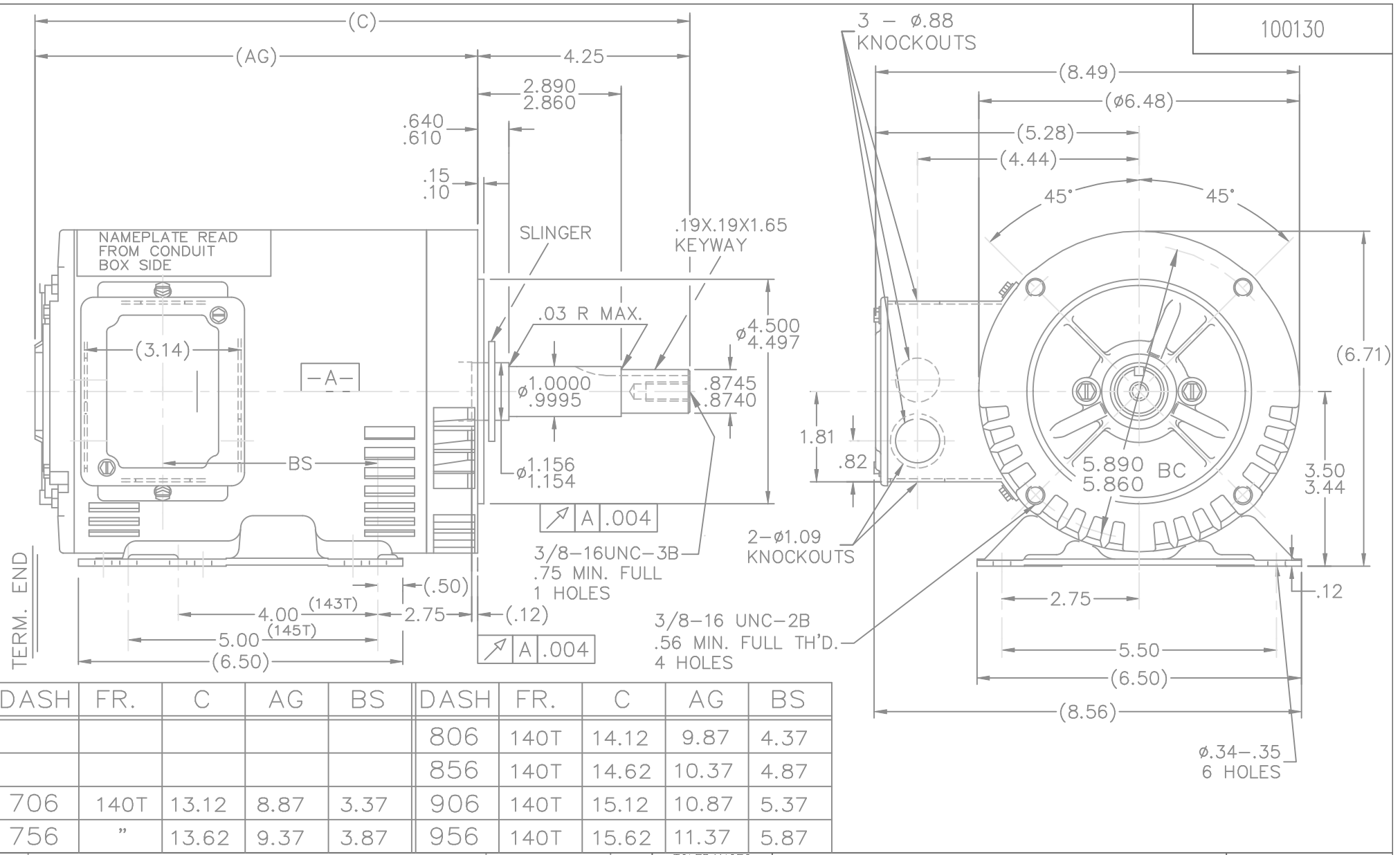

DASH	FR.	C	AG	BS	DASH	FR.	C	AG	BS
					806	140T	14.12	9.87	4.37
					856	140T	14.62	10.37	4.87
706	140T	13.12	8.87	3.37	906	140T	15.12	10.87	5.37
756	"	13.62	9.37	3.87	956	140T	15.62	11.37	5.87

				TOLERANCES UNLESS SPECIFIED		MARATHON ELECTRIC	DRAWN SMC 09-30-1999							
NO.	REVISION	BY & DATE	CHK	ANG	±		DEC.	INCHES	CHK	ET	APPD	ML	SCALE	3=8
5	UPDATED DRAWING	RJW 03-28-2007	ML	DEC.	±.1	<b>MARATHON ELECTRIC</b> TITLE OUTLINE 140 FR. - DR. PR. 3 $\phi$ - C'FACE JM EXT. MAT'L. FINISH								
4	REMOVED THE DASH VALUE 656. ECN:9600	NB 11-20-2006		.X										
3	REDRAWN IN AUTOCAD	TAT 07-06-2004	ML	.XX	±.03									
2	ADDED PACKAGING DIMS. CN 27400-456	BR 09-30-1999		.XXX	±.005									
1	REDRAWN ON CADD, ADDED DASH 956 3877534	SMC 01-23-1992		.XXXX	±.0005									
				ANG	±7'30"									
			RFP			CAD FILE	100130	SIZE	A	DRAWING NO.	100130	PAGE	OF	REV.
			DIST	WP										5

EE7308

THREE PHASE  
DUAL VOLTAGE MOTOR



VIEW OF TERMINAL END

REF.  
WINDING DIAGRAM

T8Y, T2Y, T2BL, T4BX, T2EC, T2G  
T6BZ, T2B, T6BL, T4AV, T6B, T4B

OPTIONAL CORD  
CONNECTION

L1 — WHITE  
L2 — RED  
L3 — BLACK

NO.	REVISION	BY & DATE	CHK	ANG	TOLERANCES UNLESS SPECIFIED		FINISH	DRAWN RM 11/20/1990				
					DEC.	INCHES						
5	CHG TO REGAL LOGO	SL 09/10/2015	AB					CHK ML 11/21/1990				
4	REVISED IEC NOTATIONS	MSG 11/15/2011	CMN	.X	±.1			APPD SAS 04/24/2003				
3	ADDED IEC NOTATIONS... (U1), (V1) ETC. MU95194	MSG 5/10/2010	MJS	.XX	±.02		TITLE CONNECTION DIAGRAM	SCALE 1=1				
2	ADDED THE OPTIONAL CORD CONNECTION MU46318	RDH 04/24/2003	DRS	.XXX	±.005		3Ø - DUAL VOLTAGE MOTOR	REF				
1	REDRAWN	RM 11/20/1990		.XXXX	±.0005		MAT'L.	FMF				
					±7'30"			PREV				
THIS DRAWING IN DESIGN AND DETAIL IS OUR PROPERTY AND MUST NOT BE USED EXCEPT IN CONNECTION WITH OUR WORK ALL RIGHTS OF DESIGN AND INVENTION ARE RESERVED THIS IS AN ELECTRONICALLY GENERATED DOCUMENT - DO NOT SCALE THIS PRINT							RFP	CAD FILE ee7308	SIZE A	DRAWING NO. EE7308	PAGE OF 5	REV. 5
							DIST WP					



Regal Beloit America, Inc.

3Ø - DUAL VOLTAGE MOTOR

**CERTIFICATION DATA SHEET**

**Model#:** 145TTDR6034 AA      **WINDING#:** ZT4258 NONE 3  
**CONN. DIAGRAM:** A-EE7308      **ASSEMBLY:** F1 ONLY  
**OUTLINE:** A-100130-906

**TYPICAL MOTOR PERFORMANCE DATA**

HP	KW	SYNC. RPM	F.L. RPM	FRAME	ENCLOSURE	KVA CODE	DESIGN
1 1/2&1	1.12&.75	1800	1755&1465	145JM	DP	M	B

PH	Hz	VOLTS	FL AMPS	START TYPE	DUTY	INSL	S.F	AMB°C	ELEVATION
3	60/50	230/460#190/ 380	4.4/2.2&4.2/ 1	LINE OR INVERTER	CONTINUOU S	F3	1.15/1.0	40	3300

FULL LOAD EFF: 86.5&85.5	3/4 LOAD EFF: 86	1/2 LOAD EFF: 83.8	GTD. EFF	ELEC. TYPE	NO LOAD AMPS
FULL LOAD PF: 75&70	3/4 LOAD PF: 67	1/2 LOAD PF: 54.5	84	SQ CAGE INV RATED	2.5 / 1.3

F.L. TORQUE	LOCKED ROTOR AMPS	L.R. TORQUE	B.D. TORQUE	F.L. RISE°C
4.5 LB-FT	39.6 / 19.8	16.65 LB-FT 370	21.65 LB-FT 481	32

SOUND PRESSURE @ 3 FT.	SOUND POWER	ROTOR WK^2	MAX. WK^2	SAFE STALL TIME	STARTS /HOUR	APPROX. MOTOR WGT
56 dBA	66 dBA	0 LB-FT^2	10 LB-FT^2	20 SEC.	2	43 LBS.

**\*\*\* SUPPLEMENTAL INFORMATION \*\*\***

DE BRACKET TYPE	ODE BRACKET TYPE	MOUNT TYPE	ORIENTATION	SEVERE DUTY	HAZARDOUS LOCATION	DRIP COVER	SCREENS	PAINT
C-FACE	STANDARD	RIGID	HORIZONTAL	FALSE	NONE	FALSE	NONE	BLUE (POWDER)

BEARINGS		GREASE	SHAFT TYPE	SPECIAL DE	SPECIAL ODE	SHAFT MATERIAL	FRAME MATERIAL
DE	OPE	POLYREX EM	JM	NONE	NONE	1144 STRESSPROOF (C-223)	ROLLED STEEL
BALL	BALL						
6206	6203						

THERMO-PROTECTORS				THERMISTORS	CONTROL	SPACE /n HEATERS
THERMOSTATS	PROTECTORS	WDG RTDs	BRG RTDs	NONE	FALSE	NONE VOLTS
NONE	NOT	NONE	NONE			

If Inverter equals NONE, contact factory for further information

INVERTER TORQUE: CONSTANT 10:1
INV. HP SPEED RANGE: NONE
ENCODER: NONE
NONE NONE
NONE NONE PPR
BRAKE: NONE NONE
NONE P/N NONE
NONE NONE
NONE FT-LB NONE V NONE Hz

\*  
N  
O  
T  
E  
S  
\*

DATE: 06/23/2017 06:51:42 AM  
 FORM 3531 REV.3 02/07/99  
 \*\* Subject to change without notice.

Data Sheet

Date: 16-06-2017  
 Customer: \_\_\_\_\_  
 Attention: \_\_\_\_\_  
 Submitted by: FAREEDA DUDEKULA



145TTDR6034

Submittal

Data @ 460 V

Motor Load Data

Load	0%	25%	50%	75%	100%	115%	125%	LR
Current (Amps)	1.26	1.30	1.50	1.80	2.20	2.40	2.50	19.8
Torque (ft-lb)	0.00	1.10	2.20	3.4	4.5	5.2	5.7	16.7
RPM	1800	1788	1775	1765	1755	1,745	1740	0
Efficiency (%)		75.3	83.8	86.0	86.5	86.0	86.0	
P.F. (%)	9.3	35.2	54.5	67.0	75.0	78.5	80.0	68.0

Motor Speed Data

	LR	Pull-Up	BD	Rated	Idle
Speed (RPM)	0	120	1220	1755	1800
Current (Amps)	19.8	20.2	13.1	2.20	1.26
Torque (ft-lb)	16.7	16.6	21.7	4.5	0.00

Information Block

HP	1.5			
Sync. RPM	1800			
Frame	145			
Enclosure	DP			
Construction	TDR			
Voltage	30/460#190/38V			
Frequency	60 Hz			
Design	A			
LR Code letter	M			
Service Factor	1.15			
Temp Rise @ FL	28 ° C			
Duty	CONT			
Ambient	40 ° C			
Elevation	1,000 feet			
Rotor/Shaft wk <sup>2</sup>	0.00 Lb-Ft <sup>2</sup>			
Ref Wdg	ZT4258 NONE			
Sound Pressure @ 1M	56 dBA			
VFD Rating	CONSTANT 10:1			
Outline Dwg	A-100130-906			
Conn. Diag	A-EE7308			
Additional Specifications:				
0				
365THFS8036				
EQUIV CKT (OHMS / PHASE)				
R1	R2	X1	X2	Xm
0.0000	0.0000	0.0000	0.0000	0.0000

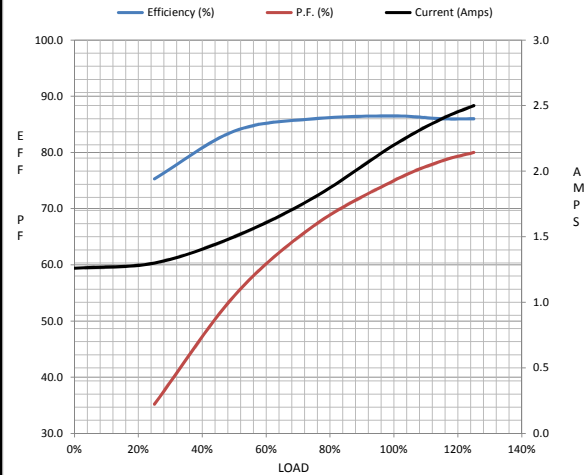

Speed -Torque Curve

