

# PRODUCT INFORMATION PACKET



Model No: CM38P17FZ17B

Catalog No: M1145038.00

..1/6HP..43RPM.38.TEFC.115/230V.1PH.60HZ.....CM38P17FZ17B.13...40:1.AC GEARMOTORS SUB-FHP..113LBIN.....

Right Angle



Regal and Leeson are trademarks of Regal Beloit Corporation or one of its affiliated companies.

©2018 Regal Beloit Corporation, All Rights Reserved. MC017097E





### Nameplate Specifications

Output HP	<b>0.16 Hp</b>	Output KW	<b>0.12 kW</b>
Frequency	<b>60 Hz</b>	Voltage	<b>110 V</b>
Current	<b>2.0/1.0 A</b>	Speed	<b>43 rpm</b>
Service Factor	<b>1</b>	Phase	<b>1</b>
Duty	<b>Continuous</b>	Insulation Class	<b>F</b>
KVA Code	<b>D</b>	Frame	<b>38</b>
Enclosure	<b>Totally Enclosed Fan Cooled</b>	Overload Protector	<b>No</b>
Ambient Temperature	<b>40 °C</b>	Drive End Bearing Size	<b>6201</b>
Opp Drive End Bearing Size	<b>6201</b>	UL	<b>Recognized</b>
CSA	<b>Y</b>	CE	<b>Y</b>

### Technical Specifications

Rotation	<b>Reversible</b>	Mounting	<b>Special</b>
Shaft Type	<b>Right Angle</b>	Overall Length	<b>12.31 in</b>
Frame Length	<b>5.88 in</b>	Shaft Diameter	<b>0.625 in</b>
Shaft Extension	<b>1.8 in</b>		
Outline Drawing	<b>M1030422-M1145038</b>	Connection Diagram	<b>M1005040.02</b>

This is an uncontrolled document once printed or downloaded and is subject to change without notice. Date Created: 10/15/2018

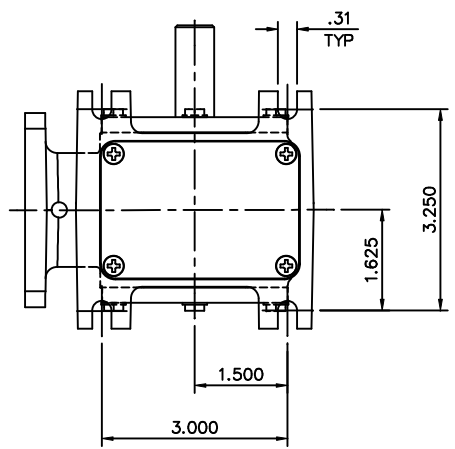
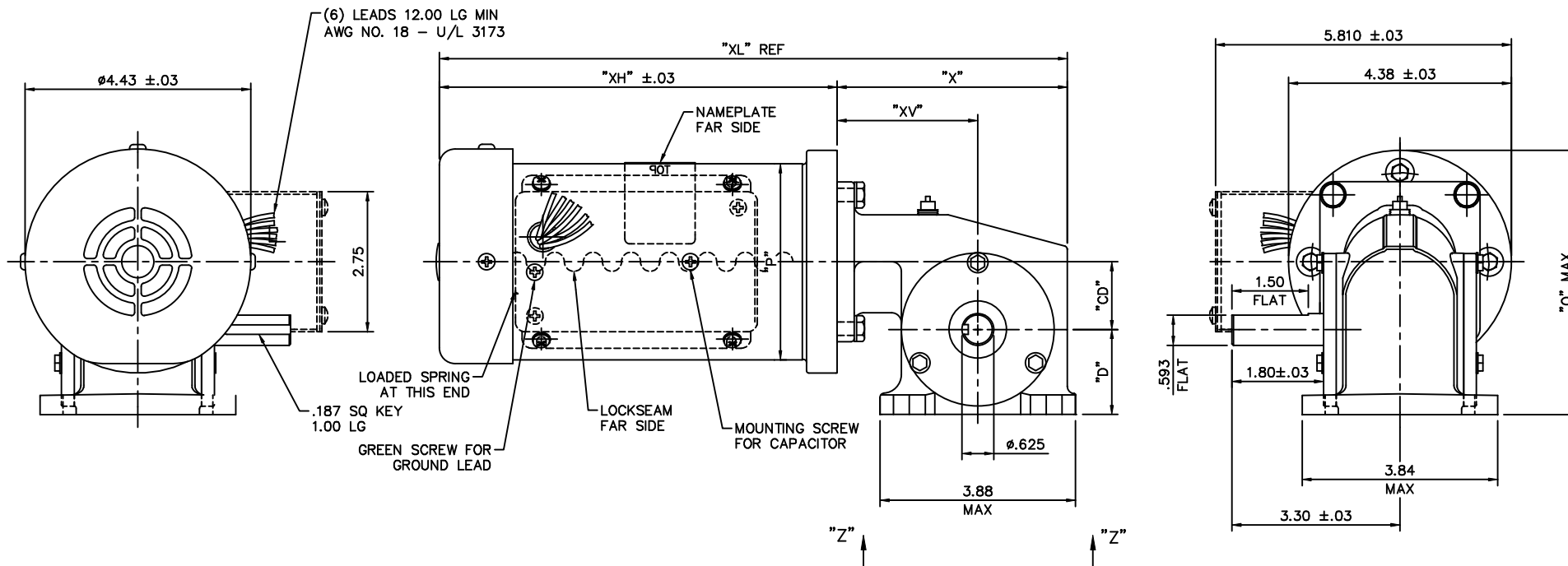

VIEW Z-Z

CATALOG NUMBER	SPEED RANGE RPM	FULL LOAD TORQUE LB.-IN.	INPUT HP	OVERHUNG LOAD LBS.	GEARMOTOR TYPE & FRAME	RATIO TO 1	"P"	"X"	"XH"	"XL"	"XV"	"D"	"O"	"CD"
M1145037.00	29	110	1/6	235	13F60-38F	60	3.85	4.50	7.81	12.31	2.74	1.67	5.20	1.333
M1145038.00	43	113	1/6	235	13F40-38F	40	3.85	4.50	7.81	12.31	2.74	1.67	5.20	1.333
M1145039.00	85	75	1/6	235	13F20-38F	20	3.85	4.50	7.81	12.31	2.74	1.67	5.20	1.333
M1145040.00	170	43	1/6	235	13F10-38F	10	3.85	4.50	7.81	12.31	2.74	1.67	5.20	1.333
M1145041.00	340	23	1/6	235	13F05-38F	5	3.85	4.50	7.81	12.31	2.74	1.67	5.20	1.333
M1145082.00	57	95	1/6	235	13F30-38F	30	3.85	4.50	7.81	12.31	2.74	1.67	5.20	1.333

				TOLERANCES UNLESS SPECIFIED		<b>LEESON</b> ELECTRIC MOTORS GEARMOTORS AND DRIVES	DRAWN SPV 02/13/95
08	CHANGED TO DIE CAST GEARBOX PER ECN 06-3024.	RPB 7/13/06	BC	DEC.	INCHES		CHK
07	CORRECTED VIEW "Z-Z" PER OTHER TWO VIEWS	BPW 03/15/02		.X	±.1	APPD	
PER ECR 73469				.XX	±.03	TITLE	SCALE 1=2
06	ADDED CATALOG NUMBER M1145082.00 AND	SAD 01/13/99		.XXX	±.005	38 FRAME A.C. RIGHT ANGLE GEARMOTOR	REF
UPDATED F.L. TORQUE TO MATCH THE CATALOG				.XXXX	±.0005	MAT'L	FMF
NO.	REVISION	BY & DATE	CHK	ANG	±1/2"	FINISH	PREV
THIS DRAWING IN DESIGN AND DETAIL IS OUR PROPERTY AND MUST NOT BE USED EXCEPT IN CONNECTION WITH OUR WORK ALL RIGHTS OF DESIGN AND INVENTION ARE RESERVED THIS IS AN ELECTRONICALLY GENERATED DOCUMENT - DO NOT SCALE THIS PRINT						CAD FILE	M1030422
						SIZE	DRAWING NO.
						B	M1030422.00
						REV.	08

M1005040.02

COLORED LEADS

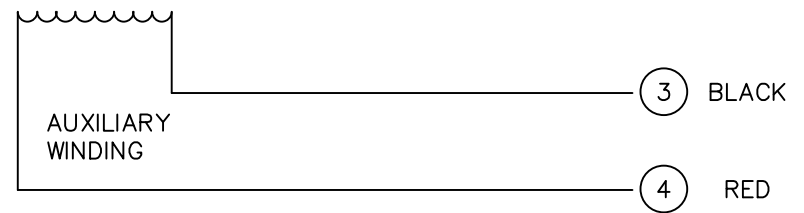
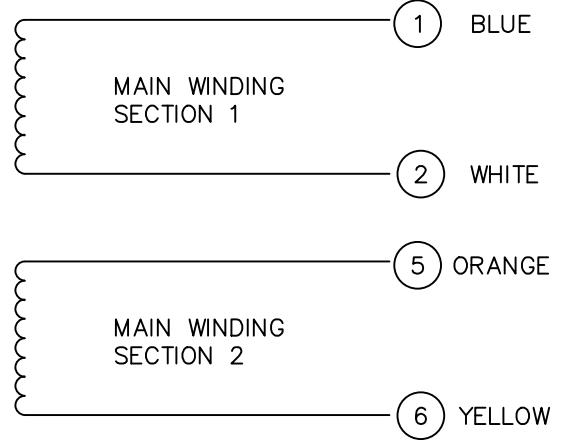
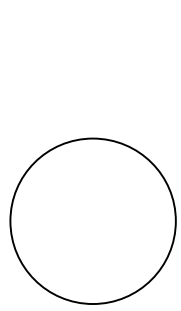

HIGH VOLTAGE CONNECTIONS

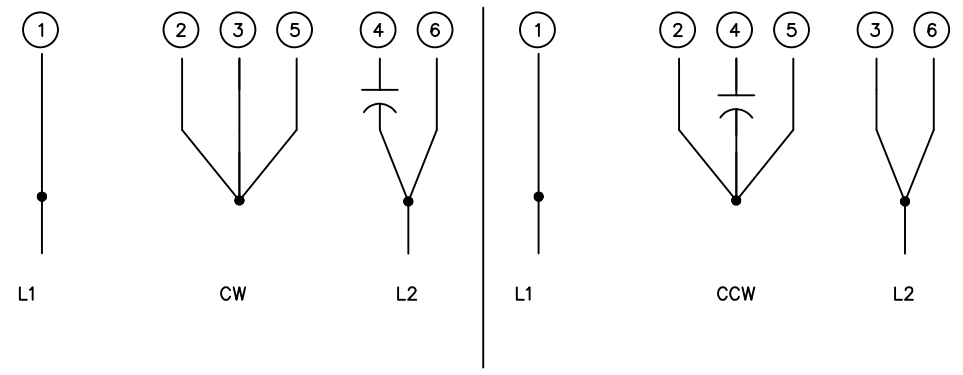

ROTATION VIEWING LEAD END OF MOTOR

LOW VOLTAGE CONNECTIONS

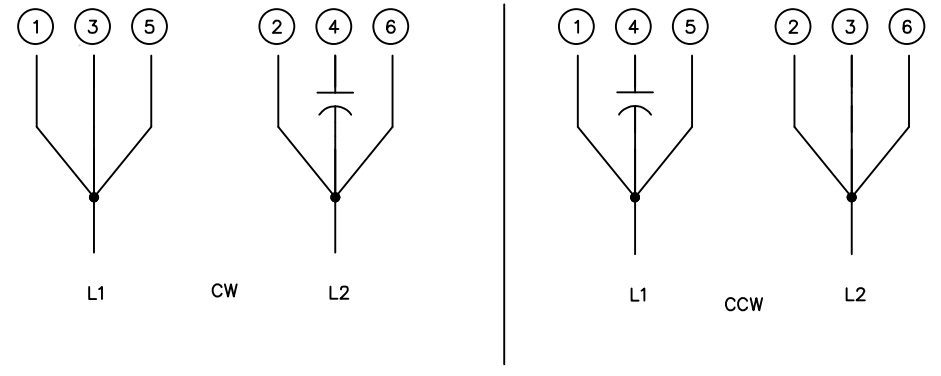

ROTATION VIEWING LEAD END OF MOTOR

				TOLERANCES UNLESS OTHERWISE SPECIFIED		<b>LEESON</b> ELECTRIC CORPORATION				
				DECIMALS						
				.00	± .01	DRAWN	DK	TITLE EXTERNAL WIRING DIAGRAM DUAL VOLTAGE DUAL ROTATION		
02	REDRAWN ON CAD	AJR	6/28/99	.000	± .005	CH'K'D.	10/3/91			
01	REMOVED CAP FROM LEFT DIAGRAM	DD	9/16/95	.0000	± .0005	APPR.	10/3/91	MAT'L.		
NO.	REVISION	BY	DATE	FRACTIONS	± 1/64	SCALE	NONE			
THIS DRAWING IN DESIGN AND DETAIL IS OUR PROPERTY AND MUST NOT BE USED EXCEPT IN CONNECTION WITH OUR WORK ALL RIGHTS OF DESIGN AND INVENTION ARE RESERVED				ANGLES	± 1/2°	REF.	FINISH		SIZE	DRAWING NO.
				INCH/MM		FMF	PR91376	LECO CORP.		A