

DUTY MASTER ALTERNATING CURRENT MOTORS

SQUIRREL-CAGE INDUCTION
CAST IRON CONSTRUCTION

ENCLOSURE: TOTALLY ENCLOSED
MOUNTING: FOOT, NEMA "C" FACE

FRAMES 364TSC-365TSC
841-XL WITH STANDARD OVERSIZED CONDUIT BOX

COOLING: FAN COOLED

617428-009

D

D

C

C

B

B

A

A

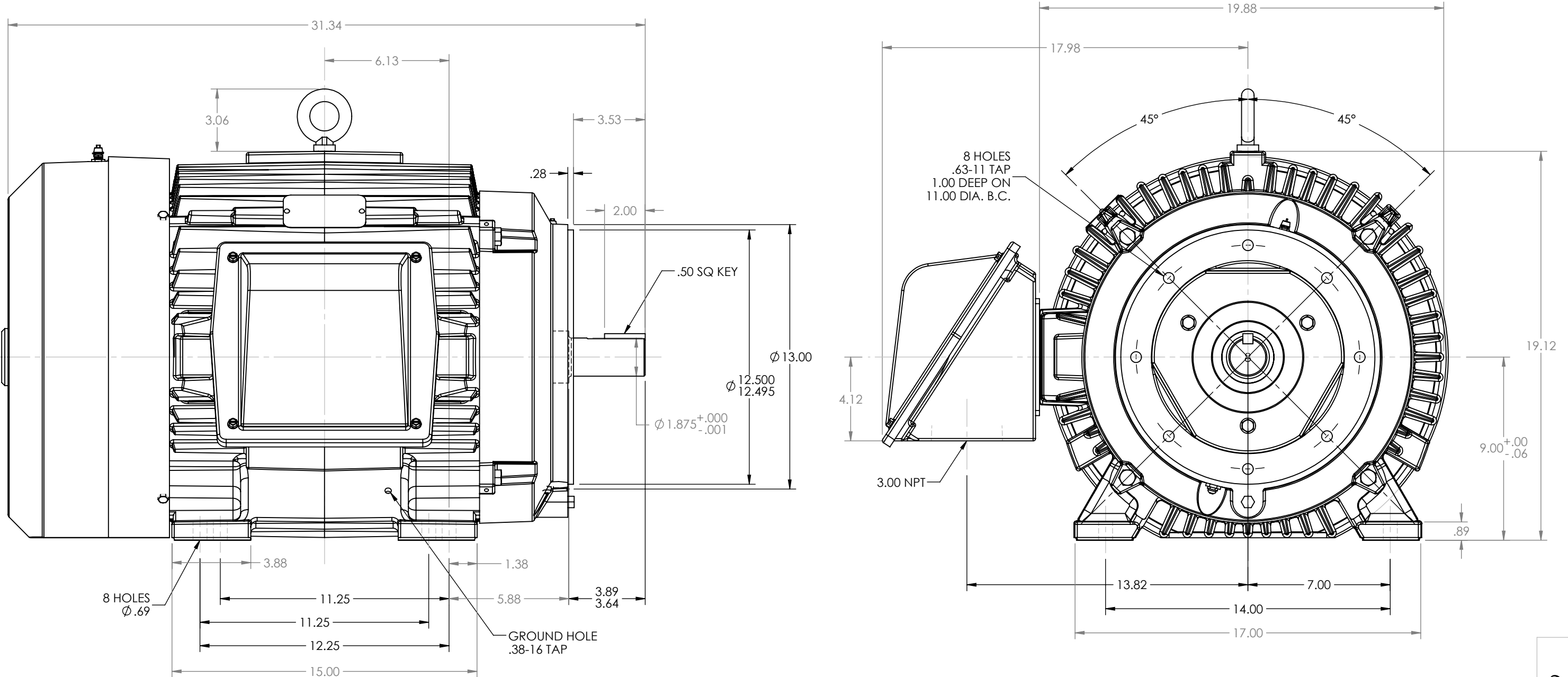

CUSTOMER IS RESPONSIBLE FOR DETERMINING THAT BALDOR'S PRODUCT WILL PERFORM SUITABLY IN THE INTENDED APPLICATION

WEIGHT (LBS): 364TSC = 874
365TSC = 899

MOTOR WEIGHTS MAY VARY BY 15% DEPENDING UPON RATING.

REV. DESC: UPDATING SHAFT AND CORRECTING BA DIMENSION			
REV: A	VERSION: 01	REVISED: 01:49:42 03/28/2014	TDR: 00000846122
MODEL NO. 617428-009		REF:	
BY: RAGJSS1		B	

BALDOR

DIM SHT TEFC 364-365TSC C FACE 841-XL W/ STD C BOX FT MTG

617428-009

8

7

6

5

4

3

2

1