

DUTY MASTER ALTERNATING CURRENT MOTORS

SQUIRREL-CAGE INDUCTION
CAST IRON CONSTRUCTION

ENCLOSURE: TOTALLY ENCLOSED
MOUNTING: FOOT

FRAMES 364TS-365TS
841-XL WITH STANDARD OVERSIZED CONDUIT BOX

COOLING: FAN COOLED

617428-001

D

C

B

A

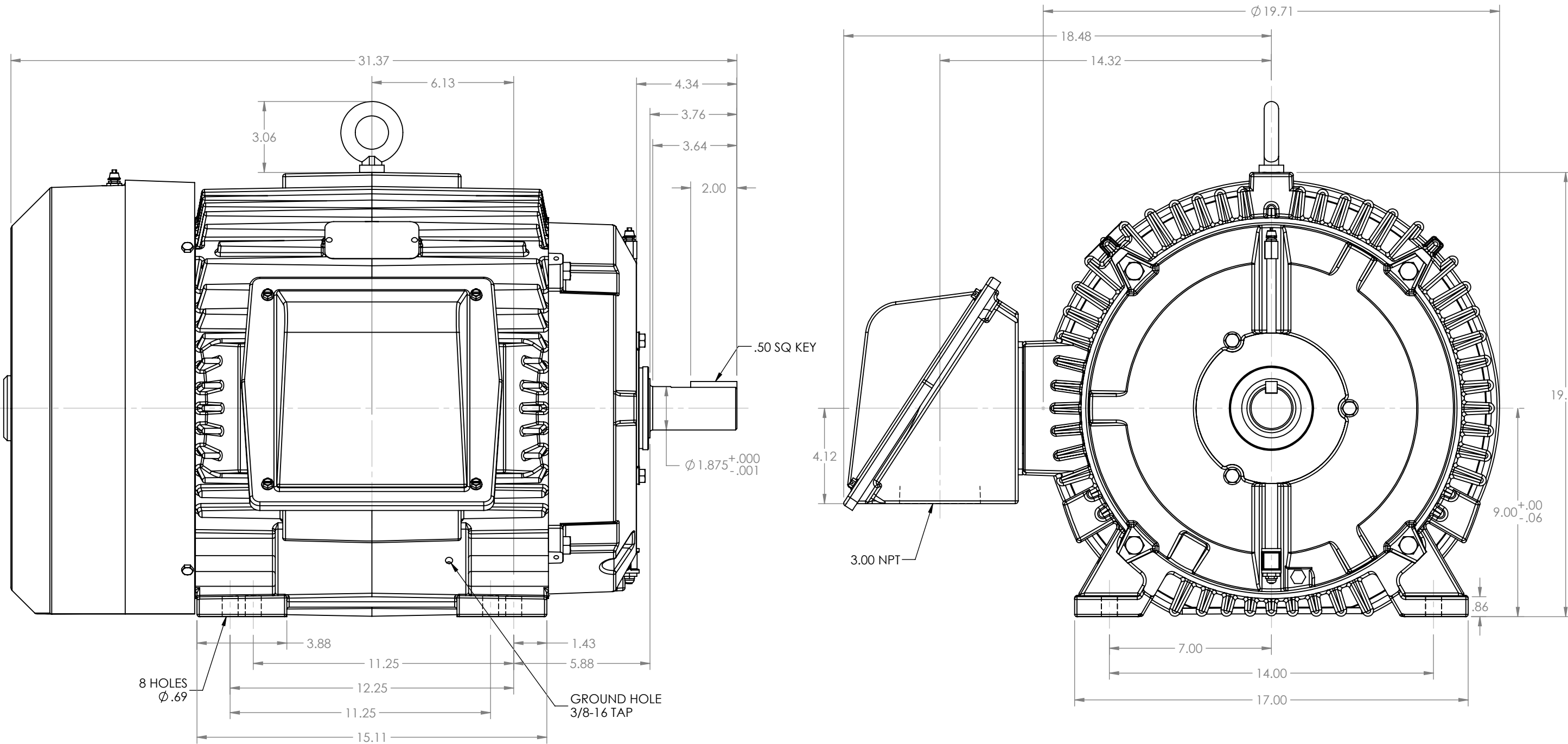

D

C

B

A

CUSTOMER IS RESPONSIBLE FOR DETERMINING THAT BALDOR'S PRODUCT WILL PERFORM SUITABLY IN THE INTENDED APPLICATION

WEIGHT (LBS): 364TS = 859
365TS = 884
MOTOR WEIGHTS MAY VARY BY 15% DEPENDING UPON RATING.

REV. DESC: UPDATING SHAFT AND CORRECTING BA DIMENSION			
REV: A	VERSION: 01	REVISED: 01:29:53 03/28/2014	TDR: 00000846122
MODEL NO. 617428-001		REF:	
BY: RAGJSS1		B	

BALDOR

DIM SHT TEFC 364-365TS STD BRKT 841-XL OS C BOX

617428-001

8

7

6

5

4

3

2

1