

PRODUCT INFORMATION PACKET

Model No: 449TTFS14055
Catalog No: Y1642
250,1800,TEFC,449T,3/60/460 PWS/YD
Fire Pump

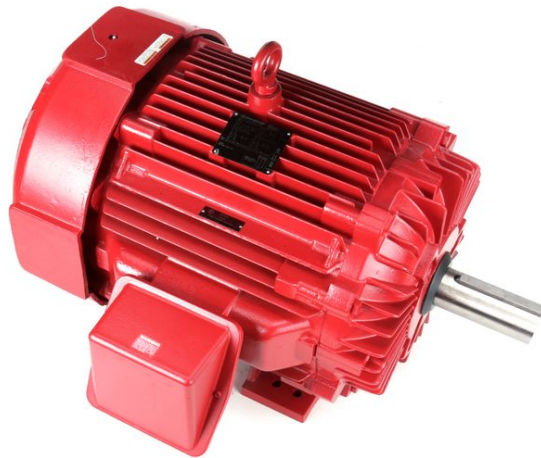

Regal and Marathon are trademarks of Regal Beloit Corporation or one of its affiliated companies.
©2018 Regal Beloit Corporation, All Rights Reserved. MC017097E



Nameplate Specifications

Output HP	250 Hp	Output KW	187 kW
Frequency	60 Hz	Voltage	460 V
Current	290 A	Speed	1785 rpm
Service Factor	1.15	Phase	3
Efficiency	95 %	Duty	CONTINUOUS
Insulation Class	F	Design Code	B
KVA Code	F	Frame	447/449T
Enclosure	TEFC	Overload Protector	NOT
Ambient Temperature	40 °C	Drive End Bearing Size	6319
Opp Drive End Bearing Size	6318	UL	No
CSA	Y	CE	Y
IP Code	43		

Technical Specifications

Electrical Type	SQ CAGE IND RUN	Starting Method	PWS & YDRUN
Poles	4	Rotation	REV
Mounting	RIGID	Motor Orientation	HORIZONTAL
Drive End Bearing	BALL	Opp Drive End Bearing	BALL
Frame Material	CAST IRON	Shaft Type	T
Overall Length	51.86 in	Frame Length	28.75 in
Shaft Diameter	3.38 in	Shaft Extension	8.75 in
Assembly/Box Mounting	F1/F2 CAPABLE		
Outline Drawing	B-SS515635-2875	Connection Diagram	A-EE7300BH

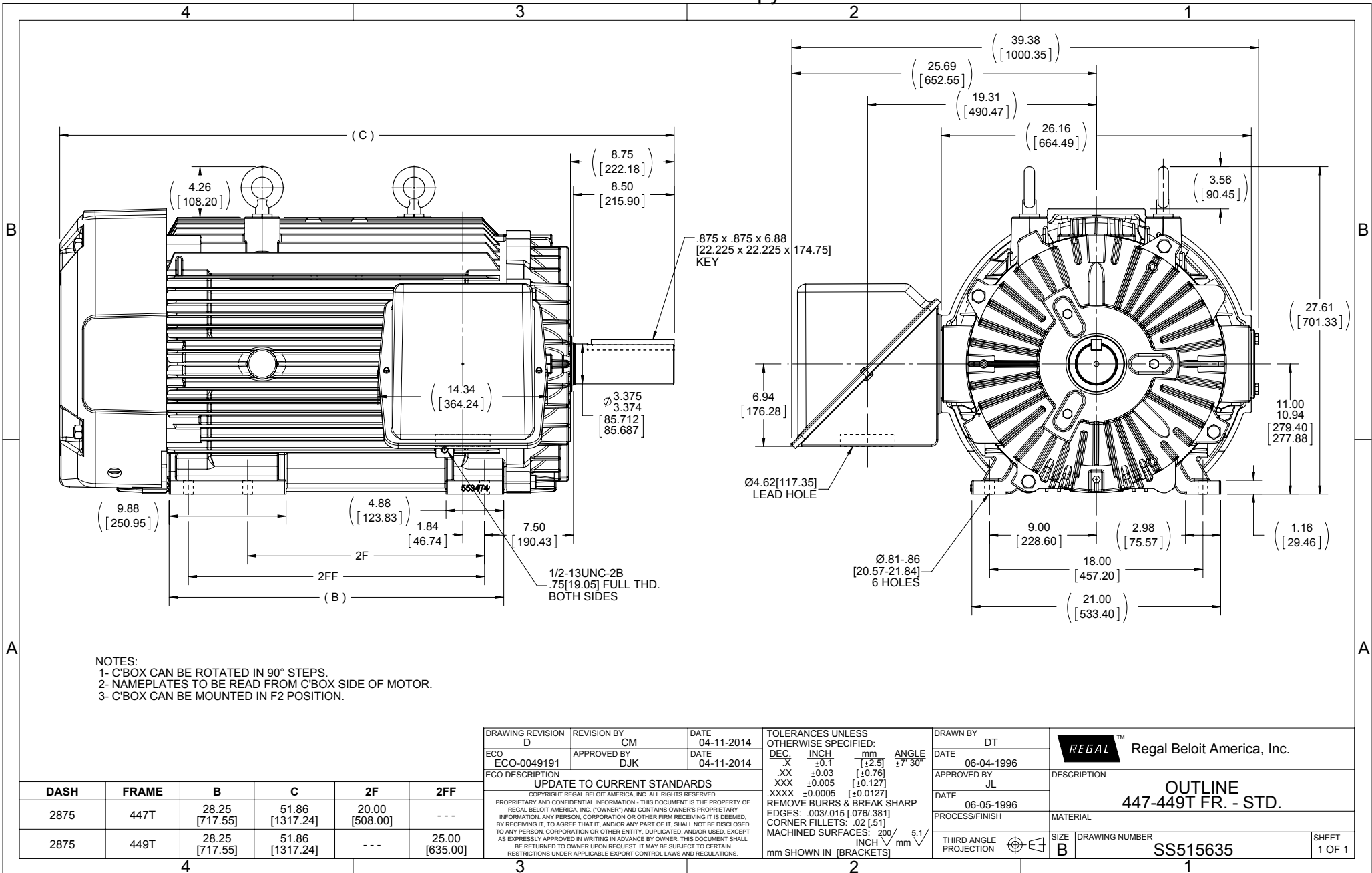

NOTES:
 1- C'BOX CAN BE ROTATED IN 90° STEPS.
 2- NAMEPLATES TO BE READ FROM C'BOX SIDE OF MOTOR.
 3- C'BOX CAN BE MOUNTED IN F2 POSITION.

DRAWING REVISION D	REVISION BY CM	DATE 04-11-2014
ECO ECO-0049191	APPROVED BY DJK	DATE 04-11-2014
ECO DESCRIPTION UPDATE TO CURRENT STANDARDS COPYRIGHT REGAL BELOIT AMERICA, INC. ALL RIGHTS RESERVED. PROPRIETARY AND CONFIDENTIAL INFORMATION - THIS DOCUMENT IS THE PROPERTY OF REGAL BELOIT AMERICA, INC. (OWNER) AND CONTAINS OWNER'S PROPRIETARY INFORMATION. ANY PERSON, CORPORATION OR OTHER FIRM RECEIVING IT IS DEEMED, BY RECEIVING IT, TO AGREE THAT IT, AND/OR ANY PART OF IT, SHALL NOT BE DISCLOSED TO ANY PERSON, CORPORATION OR OTHER ENTITY, DUPLICATED, AND/OR USED, EXCEPT AS EXPRESSLY APPROVED IN WRITING IN ADVANCE BY OWNER. THIS DOCUMENT SHALL BE RETURNED TO OWNER UPON REQUEST. IT MAY BE SUBJECT TO CERTAIN RESTRICTIONS UNDER APPLICABLE EXPORT CONTROL LAWS AND REGULATIONS.		

TOLERANCES UNLESS OTHERWISE SPECIFIED:			
DEC.	INCH	mm	ANGLE
.X	±0.1	[±2.5]	±7° 30'
.XX	±0.03	[±0.76]	
.XXX	±0.005	[±0.127]	
.XXXX	±0.0005	[±0.0127]	
REMOVE BURRS & BREAK SHARP EDGES: .003/.015 [0.076/.381] CORNER FILLETS: .02 [51] MACHINED SURFACES: 200/INCH 5.1/mm SHOWN IN [BRACKETS]			

DRAWN BY DT	DATE 06-04-1996
APPROVED BY JL	DATE 06-05-1996
PROCESS/FINISH	
THIRD ANGLE PROJECTION	

Regal Beloit America, Inc.	
DESCRIPTION OUTLINE 447-449T FR. - STD.	
MATERIAL	
SIZE B	DRAWING NUMBER SS515635
SHEET 1 OF 1	

DASH	FRAME	B	C	2F	2FF
2875	447T	28.25 [717.55]	51.86 [1317.24]	20.00 [508.00]	---
2875	449T	28.25 [717.55]	51.86 [1317.24]	---	25.00 [635.00]

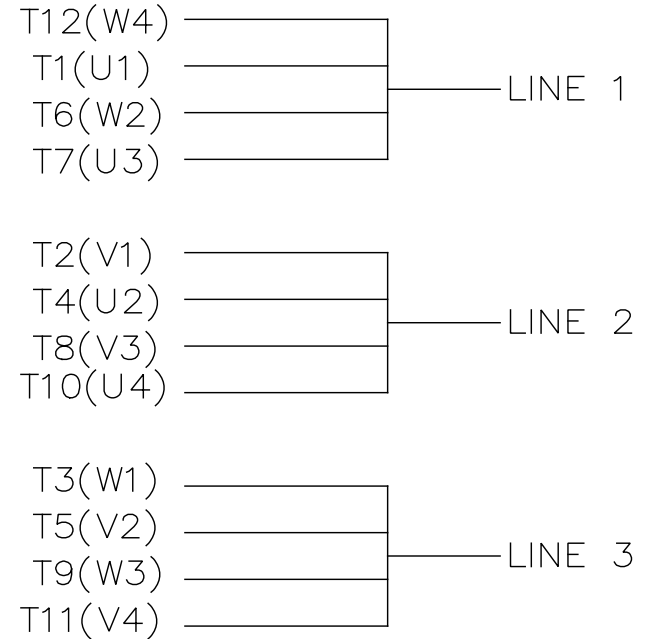
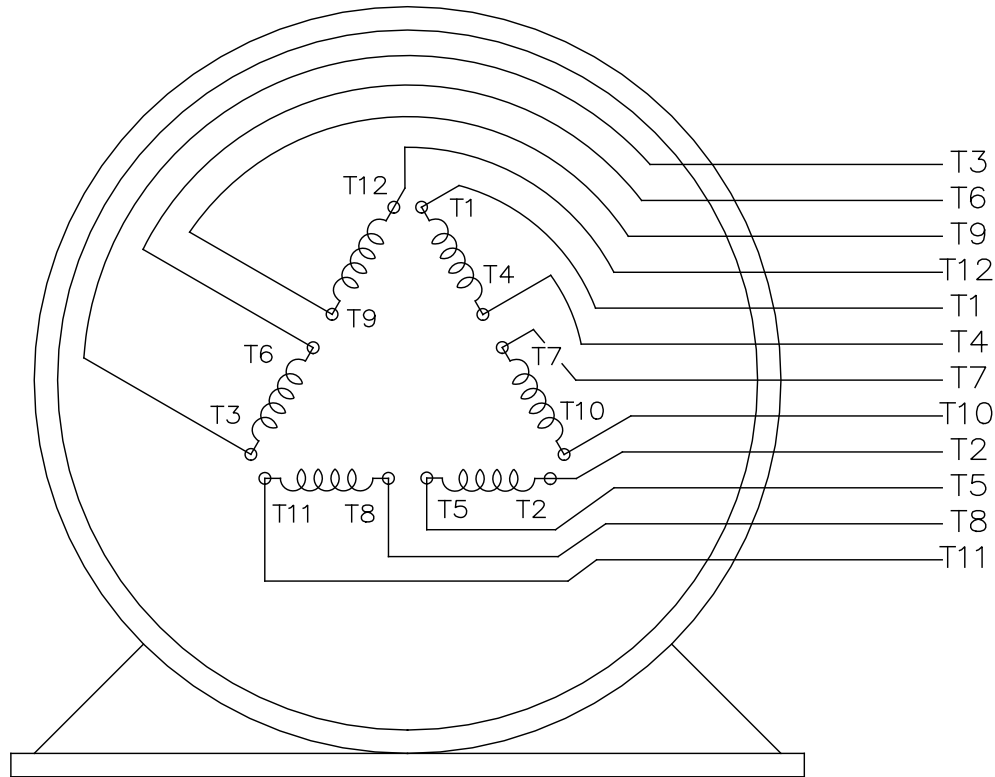

VIEW OF TERMINAL END

				TOLERANCES UNLESS SPECIFIED		REGAL REGAL - BELOIT CORPORATION	DRAWN RJW 02-11-2005			
				DEC.	INCHES		CHK	ML	02-11-2005	
				.X	±.1		APPD	GK	02-11-2005	
				.XX	±.02	TITLE CONNECTION DIAGRAM		SCALE		
D	CHANGED TO REGAL TITLE BLOCK	ECO-0108299	WGJ 08/22/2016	EMH	.XXX ±.005	12 LEAD- SINGLE VOLTAGE		REF		
1	ADDED IEC TERMINAL MARKINGS	CN 41429	JJB 05/24/2007	ML	.XXXX ±.0005	MAT'L.		FMF		
NO.	REVISION	BY & DATE	CHK	ANG	±7'30"	FINISH		PREV		
THIS DRAWING IN DESIGN AND DETAIL IS OUR PROPERTY AND MUST NOT BE USED EXCEPT IN CONNECTION WITH OUR WORK ALL RIGHTS OF DESIGN AND INVENTION ARE RESERVED THIS IS AN ELECTRONICALLY GENERATED DOCUMENT - DO NOT SCALE THIS PRINT				RFP	02-11-2005	CAD FILE ee7300bh	SIZE	DRAWING NO.	PAGE OF	REV.
				DIST	LB		A	EE7300BH		C

