

NOTE:
1. SHAFT RUNOUT ON BOTH ENDS
(2.25" FROM END OF SHAFT)
MUST BE .002 MAX. T.I.R.

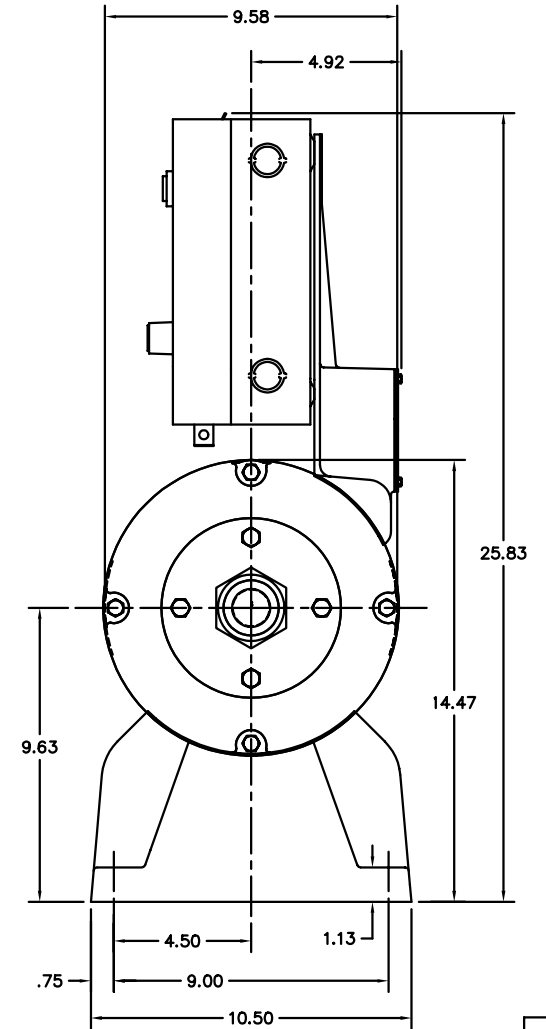

CUST. NAME		CUST. P.O.		CERTIFIED BY		MODEL		INSUL		AMB	
H.P.	MTG	TYPE	R.P.M.	VOLTS		ENCL	PHASE	FREQ	FRAME		
REV. DESC: MOVED STARTER BOX TO CENTER OF MOTOR											
REV. LTR: A	BY: JD	REVISED: 01/07/00 2:15			TDR: 0199019						
FILE: AAA00066298					MDL: -						
MTL: -					<p style="text-align: center;">BALDOR ELECTRIC Co.</p> <p style="text-align: center;">STD 14" BUFFER 37 FRAME W/ 'GE' MAGNETIC STARTER</p>						