

Chains & Sprockets	Wear Strips	Side Guide Brackets & Accessories	Levelers
Modular Belts & Sprockets	Chain & Belt Return Systems	Frame & Structure Supports	Bearings
Curves & Tracks	Side Guide Solutions	Miscellaneous Products	Related Information

21240a

## CC 600 - CC 600 TAB

www.SystemPlastSmartGuide.com

### Crate Conveyor Chains



Click here for related information.

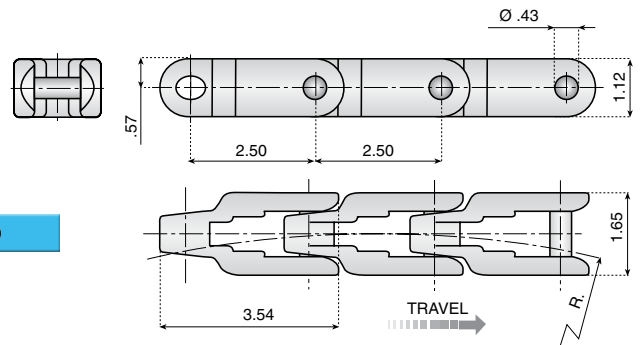

CC 600

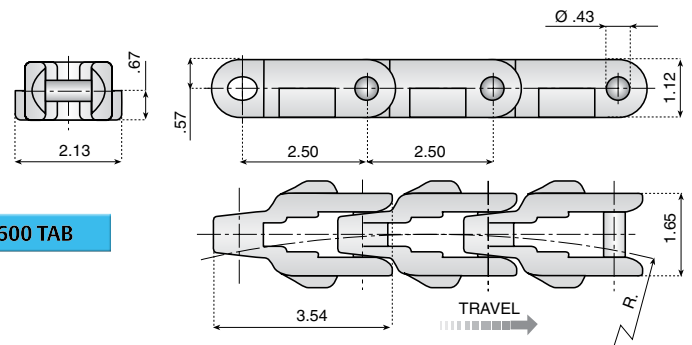

CC 600 TAB

#### Characteristics:

These chains transport plastic crates or can be used for general purpose conveying applications. They feature high strength, curving radius capability, uniform matte finish and high wear resistance.

**Pin Material:** 304 series austenitic stainless steel

Item Description	Item Number	Material		Breaking Load (lbs.)	R min.	Weight lbs/ft
		Link	Pin			
LFW600	11007	White Acetal	Stainless Steel	3147	27.55	.89
LFW600TAB	11009					1.0

## Plain Bore Sprockets

For Chains CC 600 - CC 600 TAB



Click here for related information.

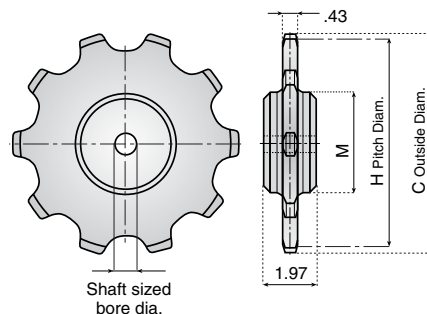

Standard Keyseats	
1/4	1/8
1" - 1-1/4" dia. shaft	3/8
1-7/16" - 1-3/4" dia. shaft	3/16

**Material:** Reinforced polyamide

Item Description	Item Number	Shaft Sized Bore Dia.	Number of Teeth	Outside Diameter C	Pitch Diameter H	M
600-8R20M-R	12326	.79*	8	6.77	6.54	3.78
600-10R20M-R	12327		10	8.47	8.07	
600-12R20M-R	12328		12	10.10	9.69	
600-14R20M-R	12329		14	11.70	11.26	

\*Plain bore pilot hole. Not sized to a shaft.