

LOAD RATINGS		
RATING	lbf	Newtons
RADIAL BASIC DYNAMIC	6,385	28,402
MAXIMUM STATIC CAPACITY	7,920	35,230

NOTES:

- BEARING IS PACKED WITH NLGI GRADE 2, LITHIUM BASED GREASE UNLESS OTHERWISE SPECIFIED
- ALL EXPOSED STEEL SURFACES HAVE BLACK OXIDE
- LIMITING SPEED:
 - A. GREASE = 2,200 RPM

RECOMMENDED MOUNTING HOLE Ø		
Limit	Inch	mm
MIN	.7500	19.0500
MAX	.7505	19.0627

MAXIMUM CLAMPING TORQUE		
Thread Type	Inch lbf	Nm
DRY	1,250	141
LUBRICATED	625	70.5

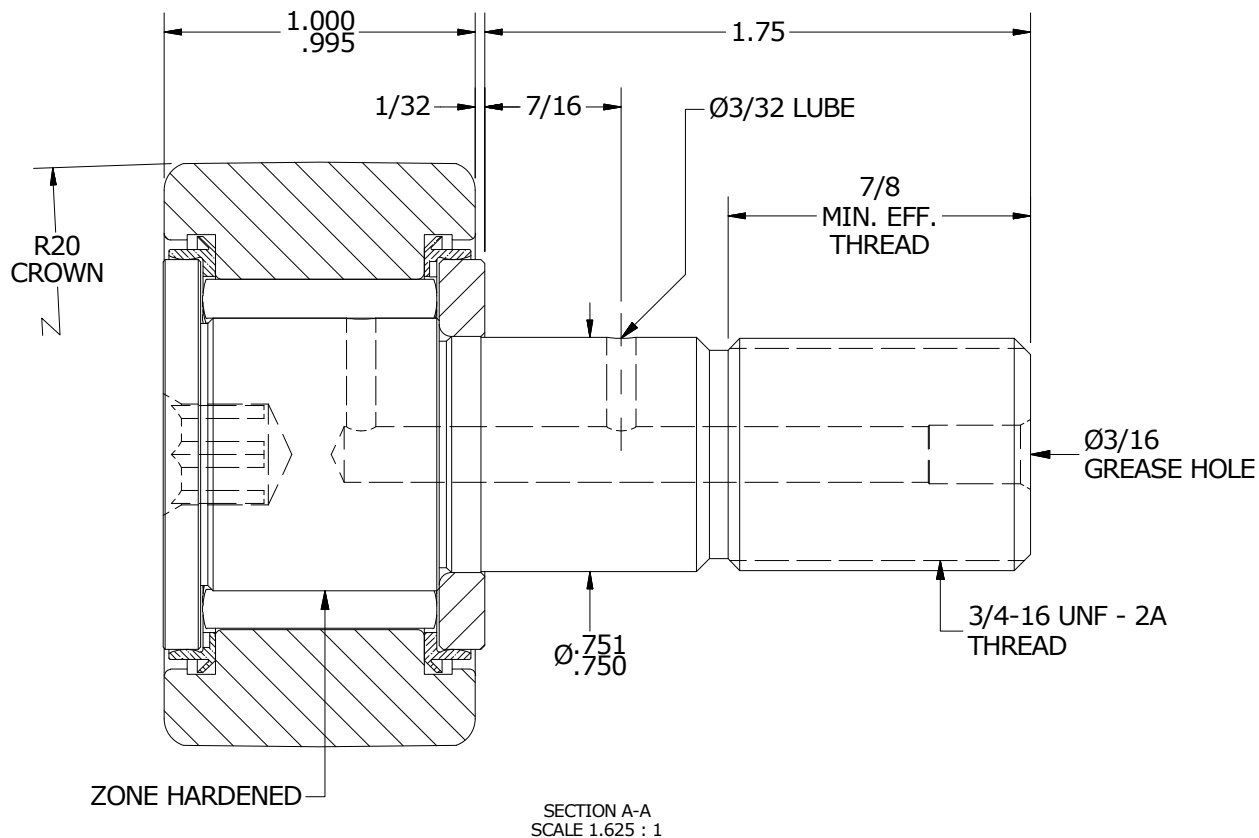
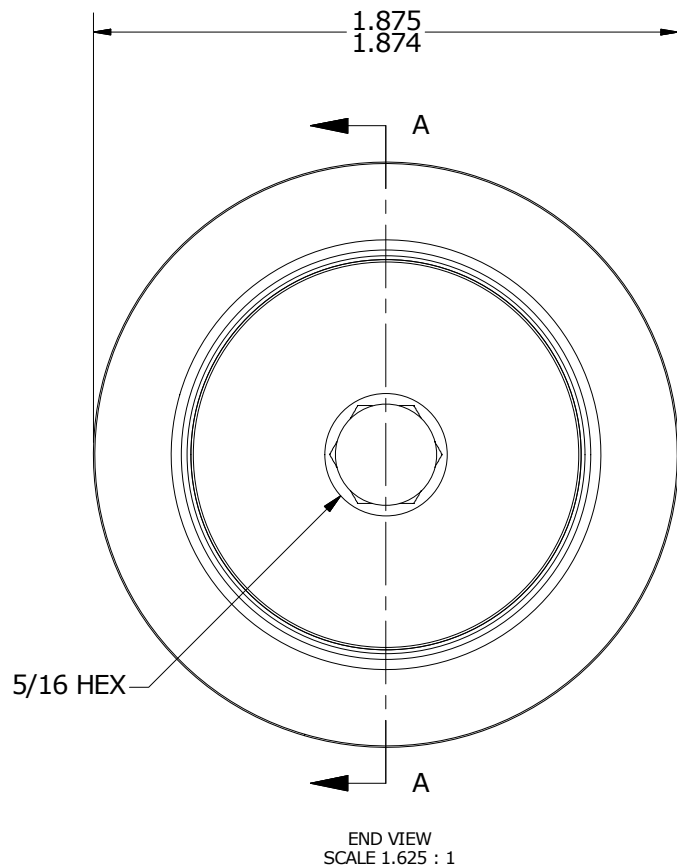
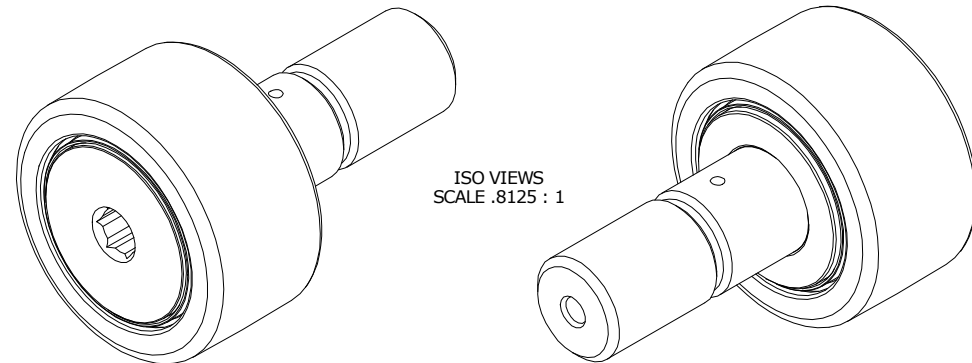

MATERIAL NOTES:

- OUTER RING - BEARING STEEL, HEAT TREATED
- STUD - BEARING STEEL, ZONE HARDENED
- NEEDLE ROLLERS - BEARING STEEL, HEAT TREATED
- WASHER - BEARING STEEL, HEAT TREATED
- SEALS - SYNTHETIC

CUSTOMER PART#

XX = ± .01
XXX = ± .005
XXXX = ± .0005
ANGLES = ± 1'
INCH [METRIC]
FRACTION = ± 1/32

CARTER MANUFACTURING IS NOT RESPONSIBLE FOR TYPOGRAPHICAL ERRORS

CARTER MANUFACTURING CO., INC.

GRAND HAVEN, MICHIGAN 49417

ENGINEERING CHANGE ORDER NOTE

REVISION

PART NAME: ASSEMBLY

PRODUCT TYPE:

B

AUTHOR BY

DRAWN BY

CHK'D BY

SALES

MATERIAL

HG

EMD

SGW

KPR

NOTED

REVISION BY

DATE

DATE

DATE

DATE

SHEET

MD

11/7/2018

7/13/2006

11/7/2018

7/12/2006

1 OF 2