

LOAD RATINGS	
RATING	Lbs
RADIAL BASIC DYNAMIC	4,840
MAXIMUM STATIC CAPACITY	11,280

NSN NO. _____ DRAWING NO. **CNBH-52-B**

- NOTES:
 1. BEARING IS PACKED WITH LITHIUM BASED #2 WEIGHT GREASE
 2. ALL EXPOSED SURFACES HAVE BLACK OXIDE

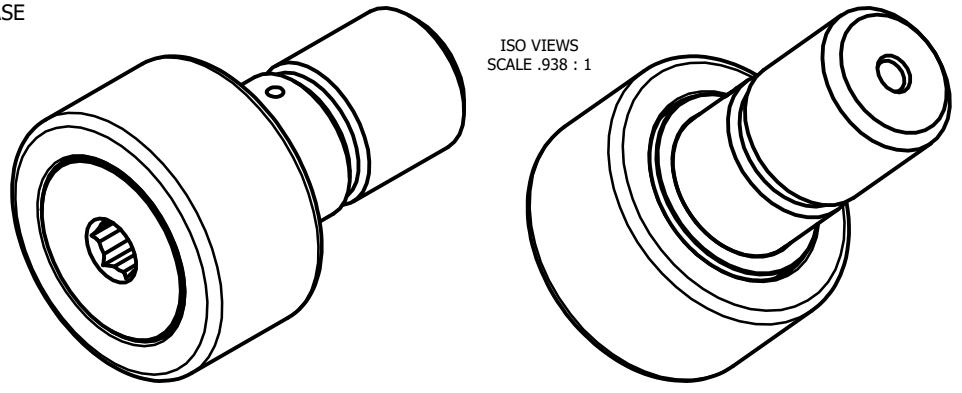

ISO VIEWS
SCALE .938 : 1

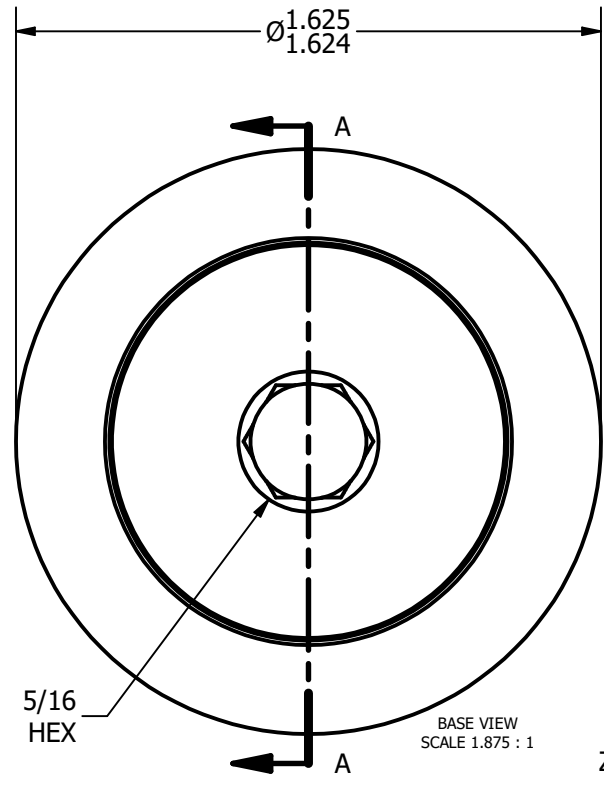

BASE VIEW
SCALE 1.875 : 1

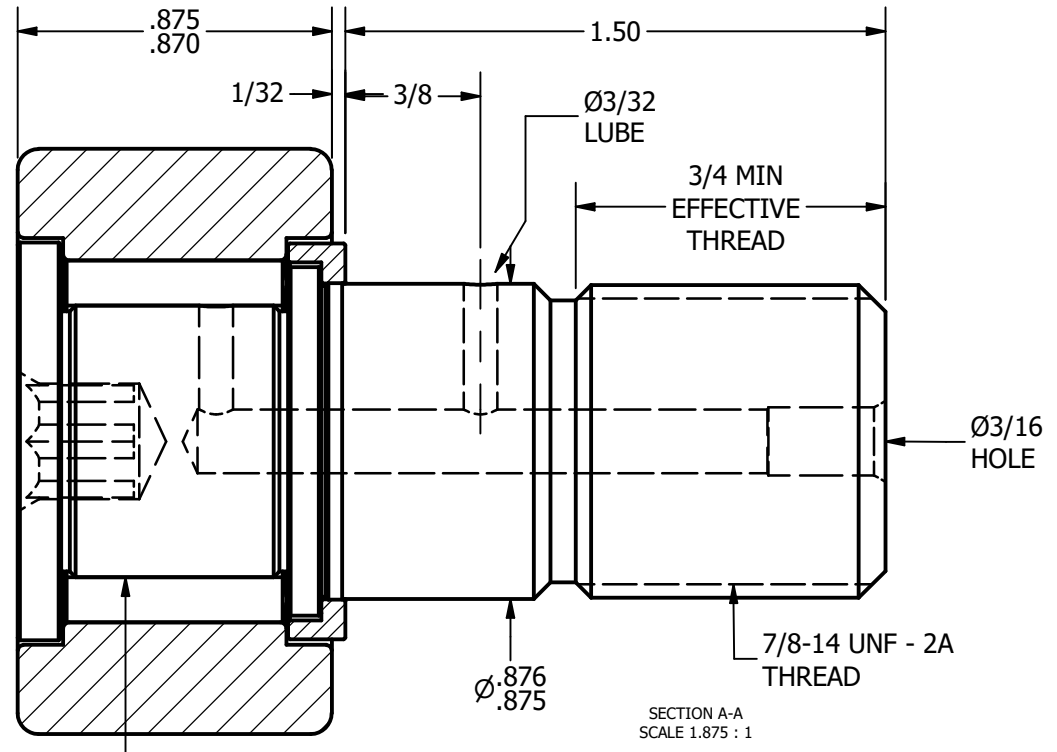

SECTION A-A
SCALE 1.875 : 1

MATERIAL NOTES:
 OUTER RACE - BEARING STEEL, HEAT TREATED
 STUD - BEARING STEEL, ZONE HARDENED
 NEEDLE ROLLER - BEARING STEEL, HEAT TREATED
 WASHER - COLD ROLLED STEEL, HEAT TREATED

CUSTOMER PART#	.XX = ± .01 .XXX = ± .005 .XXXX = ± .0005 ANGLES = ± 1' INCH [METRIC]
CHANGE NOTE:	

CARTER MANUFACTURING IS NOT RESPONSIBLE FOR TYPOGRAPHICAL ERRORS	
REVISION	
B	AUTHOR. BY DB
REV. BY	DATE
SGW	10/18/2010

CARTER MANUFACTURING CO., INC.					
GRAND HAVEN, MICHIGAN 49417					
PART NAME: ASSEMBLY			SHEET 1 OF 2		
	AUTHOR. BY	DRAWN BY	CHK'D BY	SALES	MATERIAL
	DB	JAF	MD	KR	NOTED
	DATE	DATE	DATE	DATE	DRAWING NO.
	10/18/2010	7/14/2006	10/18/2010	10/18/2010	CNBH-52-B