

LOAD RATINGS	
RATING	Lbs
RADIAL BASIC DYNAMIC	3,490
DYNAMIC THRUST LOAD	1,800
MAXIMUM STATIC CAPACITY	2,000

- NOTES:
 1. BALL BEARINGS COME PRE-PACKED WITH GREASE
 2. STUD & END CAP: ALL EXPOSED SURFACES HAVE BLACK OXIDE

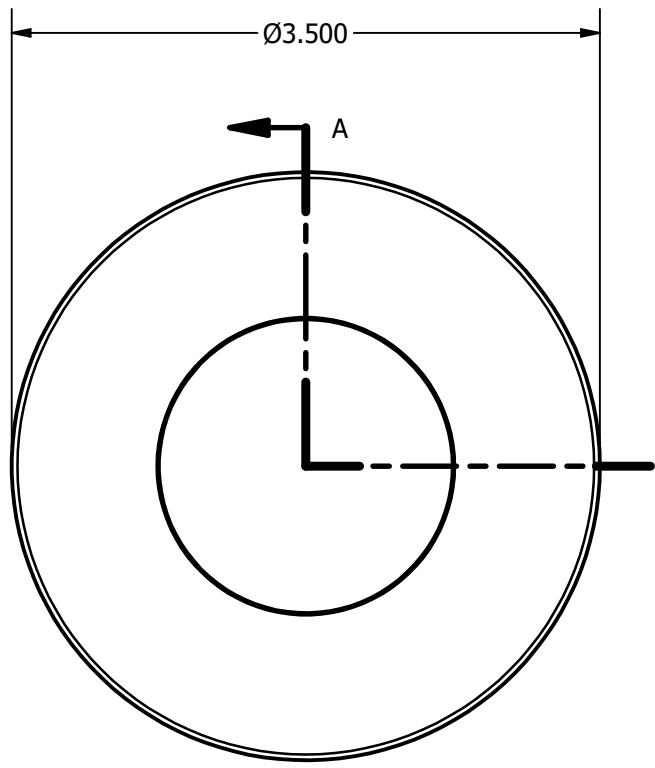

BASE VIEW
SCALE .875 : 1

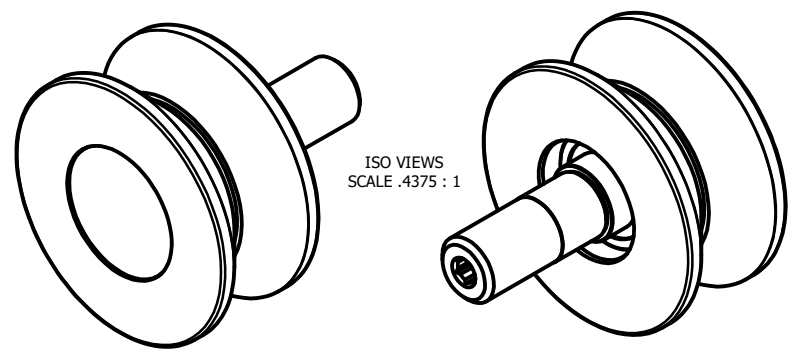
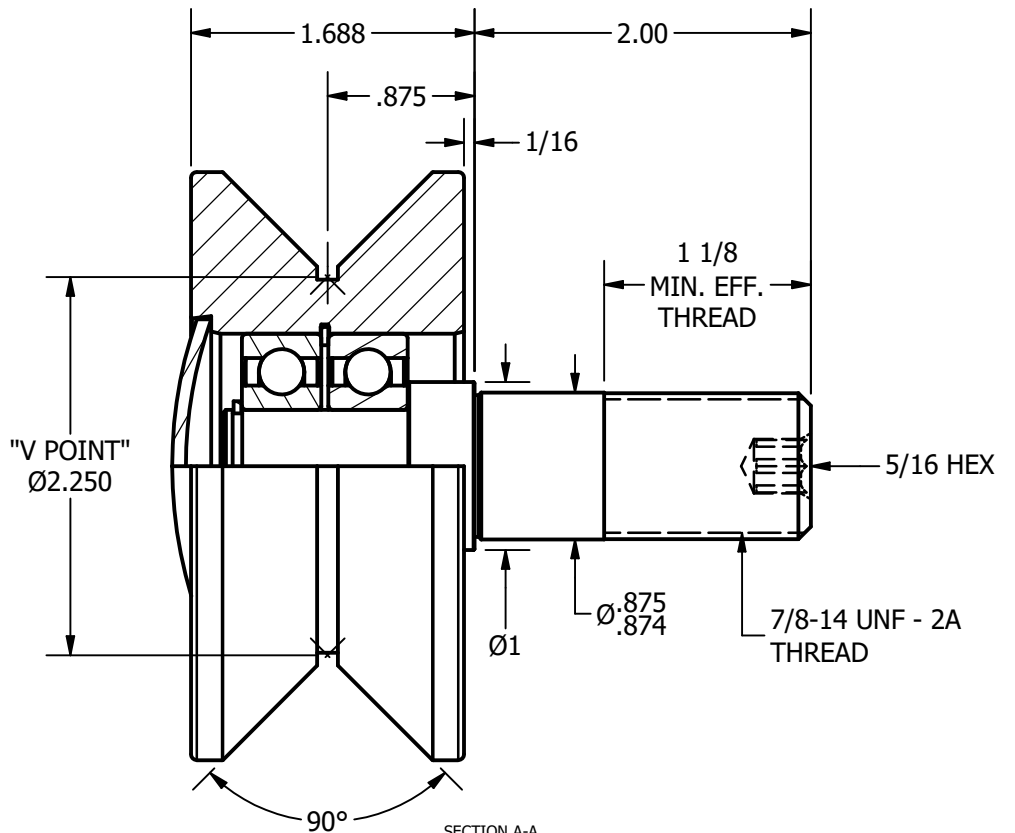

MATERIAL NOTES:
 OUTER RACE - BEARING STEEL, HEAT TREATED
 STUD - STRESSPROOF
 BEARING ASSEMBLIES - 62032RS
 INTERNAL RETAINING RING - 9131
 EXTERNAL RETAINING RING - 614
 END CAP - COLD ROLLED STEEL

CUSTOMER PART#	.XX = ± .01 .XXX = ± .005 .XXXX = ± .0005 ANGLES = ± 1' INCH [METRIC] FRACTION = ± 1/32
CHANGE NOTE:	

CARTER MANUFACTURING IS NOT RESPONSIBLE FOR TYPOGRAPHICAL ERRORS

REVISION	
B	AUTHOR. BY DB
REV. BY MD	DATE 7/26/2011

CARTER MANUFACTURING CO., INC.
 GRAND HAVEN, MICHIGAN 49417

PART NAME: ASSEMBLY		SHEET 1 OF 2			
AUTHOR. BY	DRAWN BY	CHK'D BY	SALES	MATERIAL	
DB	RAM	SGW	KR	NOTED	
REV. BY	DATE	DATE	DATE	DRAWING NO.	
MD	7/26/2011	12/31/1996	7/26/2011	7/26/2011	
VHR-350-A					