

LOAD RATINGS		
RATING	lbf	Newtons
RADIAL BASIC DYNAMIC	3,530	15,702
MAXIMUM STATIC CAPACITY	2,300	10,231

MS NO. _____ NSN NO. _____ DRAWING NO. CSCE-40-SB

RECOMMENDED MOUNTING HOLE Ø		
Limit	Inch	mm
MIN	.689	17.501
MAX	.691	17.551

NOTES:
1. BEARING IS PACKED WITH NLGI GRADE 2, FOOD GRADE H1 GREASE (UNLESS OTHERWISE SPECIFIED)

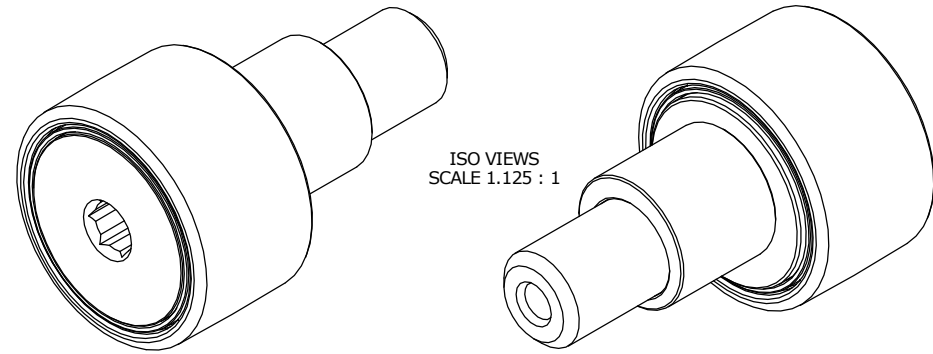

MAXIMUM CLAMPING TORQUE		
Thread Type	Inch Lbs	Nm
DRY	350	40
LUBRICATED	175	20

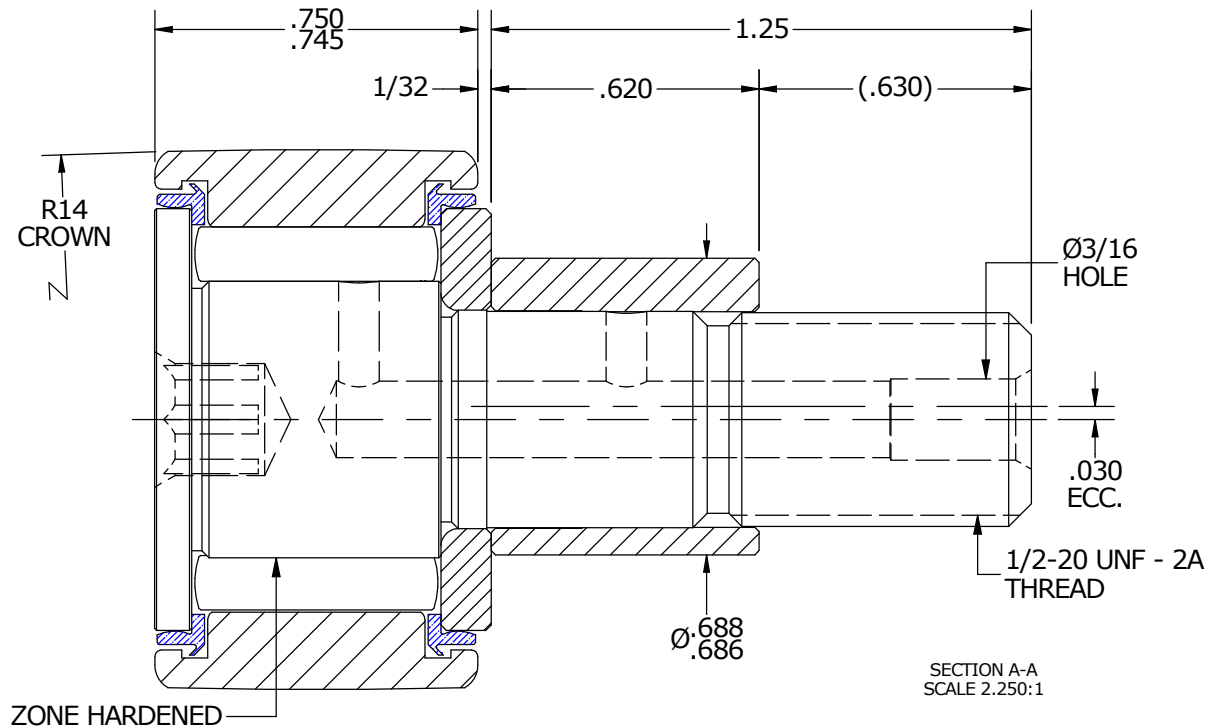
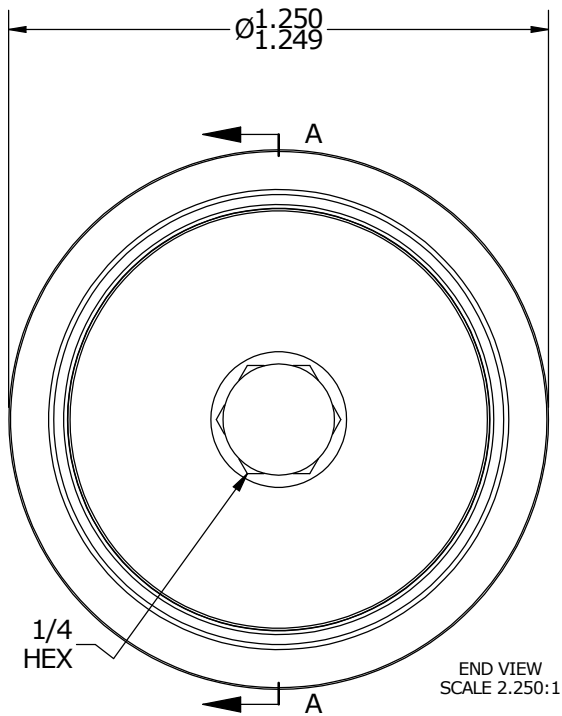

MATERIAL NOTES:

OUTER RING - 440C STAINLESS STEEL, HEAT TREATED
STUD - 440C STAINLESS STEEL, ZONE HARDENED
NEEDLE ROLLER(S) - 440C STAINLESS STEEL, HEAT TREATED
WASHER - 440C STAINLESS STEEL, HEAT TREATED
ECCENTRIC SLEEVE - 300 SERIES STAINLESS STEEL
SEAL(S) - SYNTHETIC

CUSTOMER PART#

XX = ± .01
XXX = ± .005
XXXX = ± .0005
ANGLES = ± 1'
INCH [METRIC]
FRACTION = ± 1/32

CARTER MANUFACTURING IS NOT RESPONSIBLE FOR TYPOGRAPHICAL ERRORS

CARTER MANUFACTURING CO., INC.
GRAND HAVEN, MICHIGAN 49417

REVISION

PART NAME: ASSEMBLY

ENGINEERING CHANGE ORDER NOTE

B

AUTHOR BY

DRAWN BY

CHK'D BY

SALES

MATERIAL

HG

JAF

MD

KR

NOTED

REVISION BY

DATE

DATE

DATE

DATE

SHEET

SGW

6/30/2016

7/25/2006

6/14/2016

7/15/2016

1 OF 2