

LOAD RATINGS		
RATING	lbf	Newtons
RADIAL BASIC DYNAMIC	3,144	13,985
MAXIMUM STATIC CAPACITY	5,950	26,467

MS NO. _____ NSN NO. _____ DRAWING NO. CSCH-44-SB

RECOMMENDED MOUNTING HOLE Ø		
Limit	Inch	mm
MIN	.7500	19.0500
MAX	.7505	19.0627

NOTES:
1. BEARING IS PACKED WITH NLGI GRADE 2, FOOD GRADE H1 GREASE (UNLESS OTHERWISE SPECIFIED)

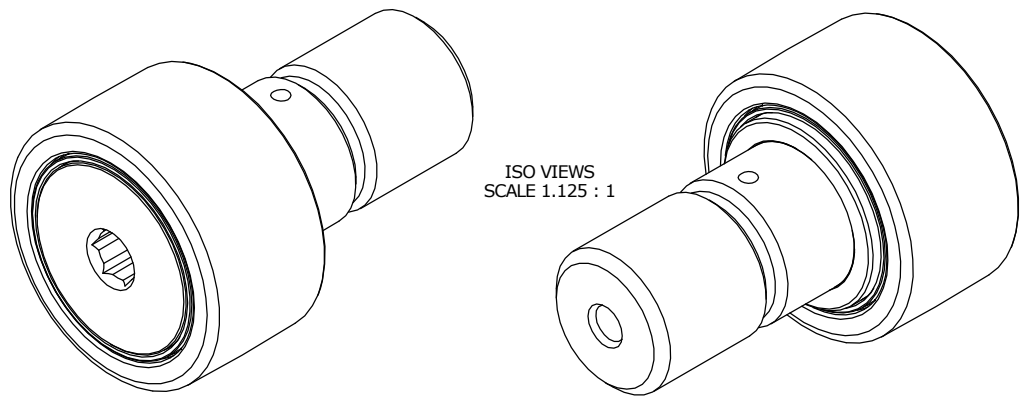

MAXIMUM CLAMPING TORQUE		
Thread Type	Inch Lbs	Nm
DRY	1,250	141
LUBRICATED	650	70.5

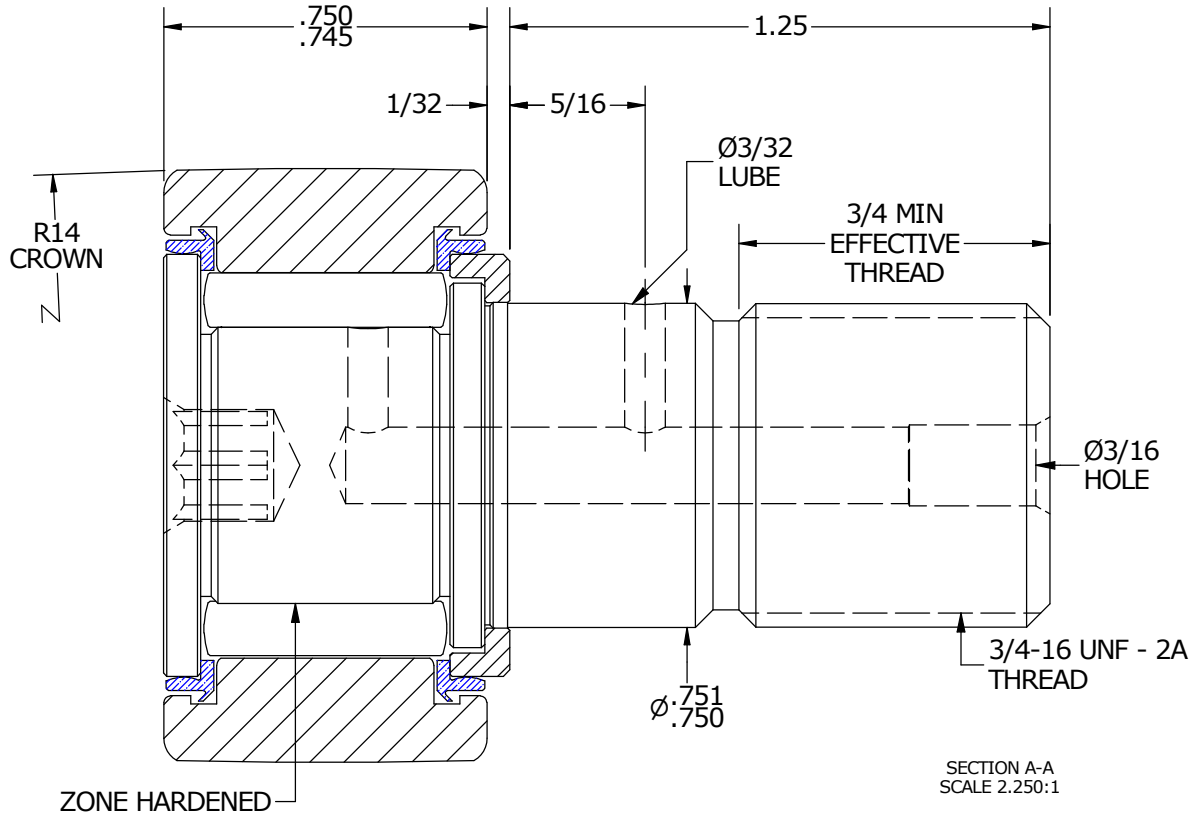
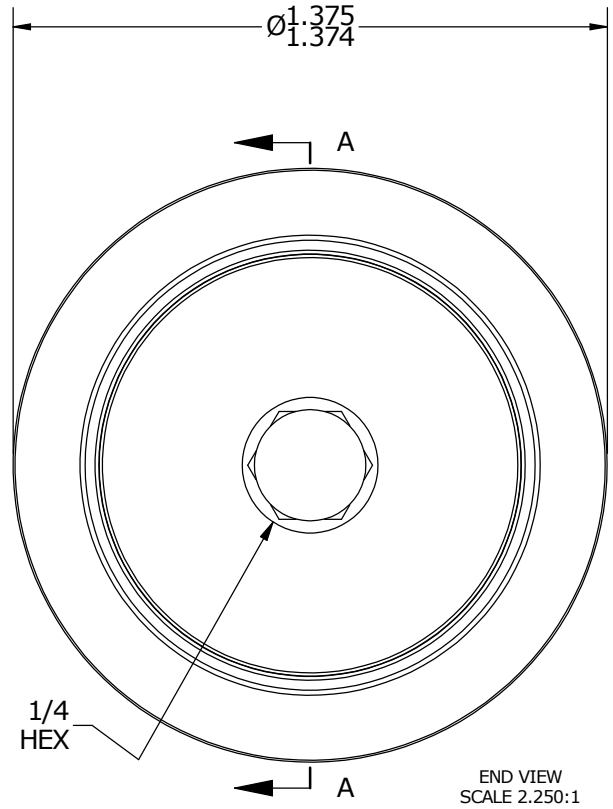

MATERIAL NOTES:
OUTER RING - 440C STAINLESS STEEL, HEAT TREATED
STUD - 440C STAINLESS STEEL, ZONE HARDENED
NEEDLE ROLLER(S) - 440C STAINLESS STEEL, HEAT TREATED
WASHER - 440C STAINLESS STEEL, HEAT TREATED
SEAL(S) - SYNTHETIC

CUSTOMER PART# _____
XX = ± .01
XXX = ± .005
XXXX = ± .0005
ANGLES = ± 1'
INCH [METRIC]
FRACTION = ± 1/32

CARTER MANUFACTURING IS NOT RESPONSIBLE FOR TYPOGRAPHICAL ERRORS

CARTER MANUFACTURING CO., INC.
GRAND HAVEN, MICHIGAN 49417

ENGINEERING CHANGE ORDER NOTE

REVISION		PART NAME: ASSEMBLY			
B	AUTHOR BY	DRAWN BY	CHK'D BY	SALES	MATERIAL
	HG	JAF	MD	KR	NOTED
REVISION BY	DATE	DATE	DATE	DATE	SHEET
SGW	6/30/2016	7/25/2006	6/14/2016	7/15/2016	1 OF 2