

LOAD RATINGS		
RATING	lbf	Newtons
RADIAL BASIC DYNAMIC	6,472	28,789
MAXIMUM STATIC CAPACITY	16,912	75,228

NOTES:  
 1. BEARING IS PACKED WITH NLGI GRADE 2, FOOD GRADE H1 GREASE (UNLESS OTHERWISE SPECIFIED)

MS NO. \_\_\_\_\_ NSN NO. \_\_\_\_\_ DRAWING NO. SY-72-S

ISO VIEW  
SCALE .750 : 1

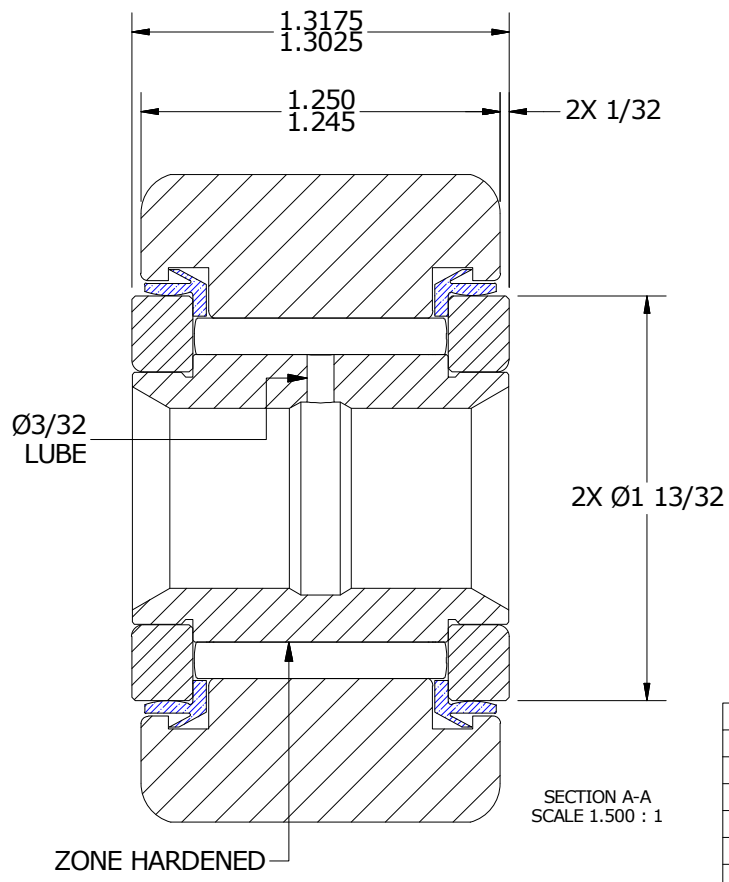
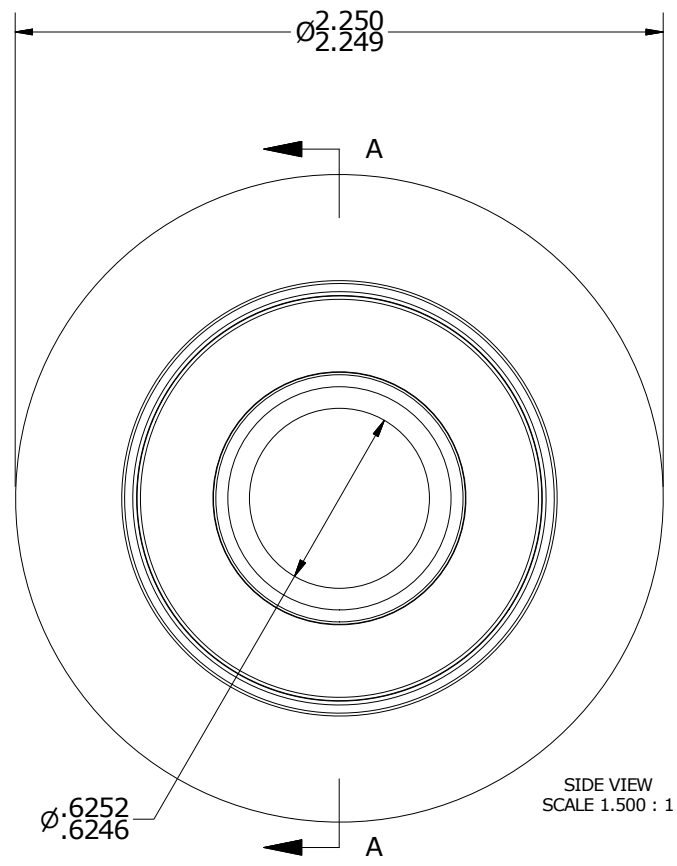
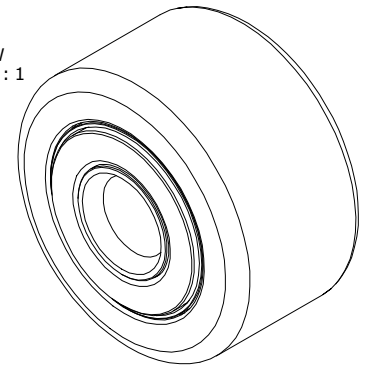

Recommended Shaft Fits		
Fit Type - Dimension	Ø (Inch)	Ø (mm)
Push - Max	.6247	15.8674
Push - Min	.6243	15.8572
Drive - Max	.6253	15.8826
Drive - Min	.6249	15.8725
Press - Max	.6257	15.8928
Press - Min	.6253	15.8826

MATERIAL NOTES:  
 OUTER RING - 440C STAINLESS STEEL, HEAT TREATED  
 INNER RING - 440C STAINLESS STEEL, ZONE HARDENED  
 NEEDLE ROLLER(S) - 440C STAINLESS STEEL, HEAT TREATED  
 WASHER(S) - 440C STAINLESS STEEL, HEAT TREATED  
 SEAL(S) - SYNTHETIC

CUSTOMER PART#	XX = ± .01 XXX = ± .005 XXXX = ± .0005 ANGLES = ± 1' INCH [METRIC] FRACTION = ± 1/32
ENGINEERING CHANGE ORDER NOTE	

CARTER MANUFACTURING IS NOT RESPONSIBLE FOR TYPOGRAPHICAL ERRORS		<b>CARTER MANUFACTURING CO., INC.</b> GRAND HAVEN, MICHIGAN 49417			
REVISION		PART NAME: ASSEMBLY		PRODUCT TYPE: CNB / SC	
<b>B</b>	AUTHOR BY HG	DRAWN BY JAF	CHK'D BY MD	SALES KR	MATERIAL NOTED
REVISION BY SGW	DATE 7/27/2018	DATE 8/9/2006	DATE 7/27/2018	DATE 7/27/2018	SHEET 1 OF 2