

PRODUCT INFORMATION PACKET



Model No: CI4D17WC4A

Catalog No: 109084.00

..1/2HP-.37KW..1750RPM.80D.IP55.180V...S1.40C.1,0SF.METRIC.CI4D17WC4A.....DC WASHGUARD ALL-STAINLESS.....

IEC



Regal and Leeson are trademarks of Regal Beloit Corporation or one of its affiliated companies.

©2018 Regal Beloit Corporation, All Rights Reserved. MC017097E





Nameplate Specifications

Output KW	0.55 kW	Voltage	180 V
Current	3.8 A	Speed	1750 rpm
Service Factor	1	Efficiency	77.3 %
Duty	S1	Insulation Class	F
Frame	80D	Enclosure	IP55
Overload Protector	No	Ambient Temperature	40 °C
Drive End Bearing Size	6205	Opp Drive End Bearing Size	6203
UL	Recognized	CSA	Y
CE	Y		

Technical Specifications

Rotation	Reversible	Mounting	Round
Overall Length	13.87 in	Frame Length	7.25 in
Shaft Diameter	0.750 in	Shaft Extension	2.05 in
Outline Drawing	031792-U80	Connection Diagram	005487

This is an uncontrolled document once printed or downloaded and is subject to change without notice. Date Created: 10/15/2018

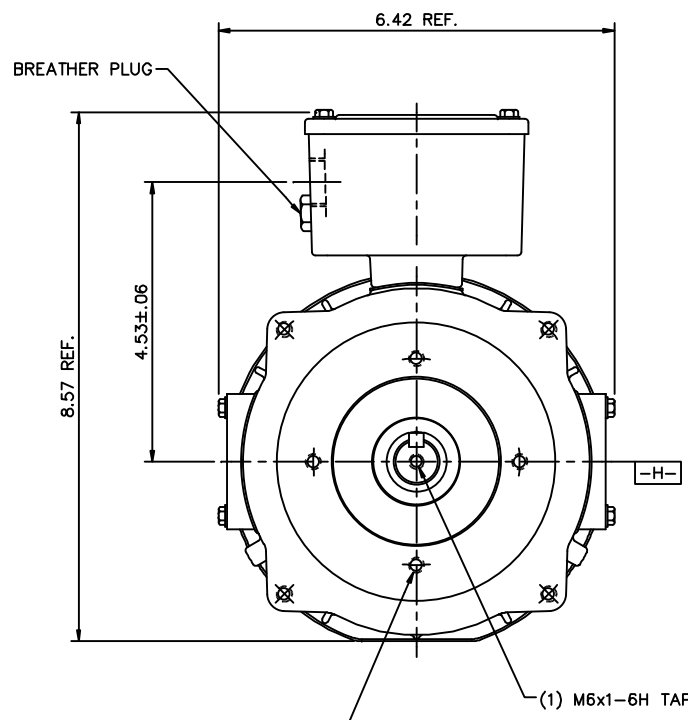

(4) M6x1-6H x .50 DEEP ON A Ø3.346 BC

(1) M6x1-6H TAP x .63 DEEP

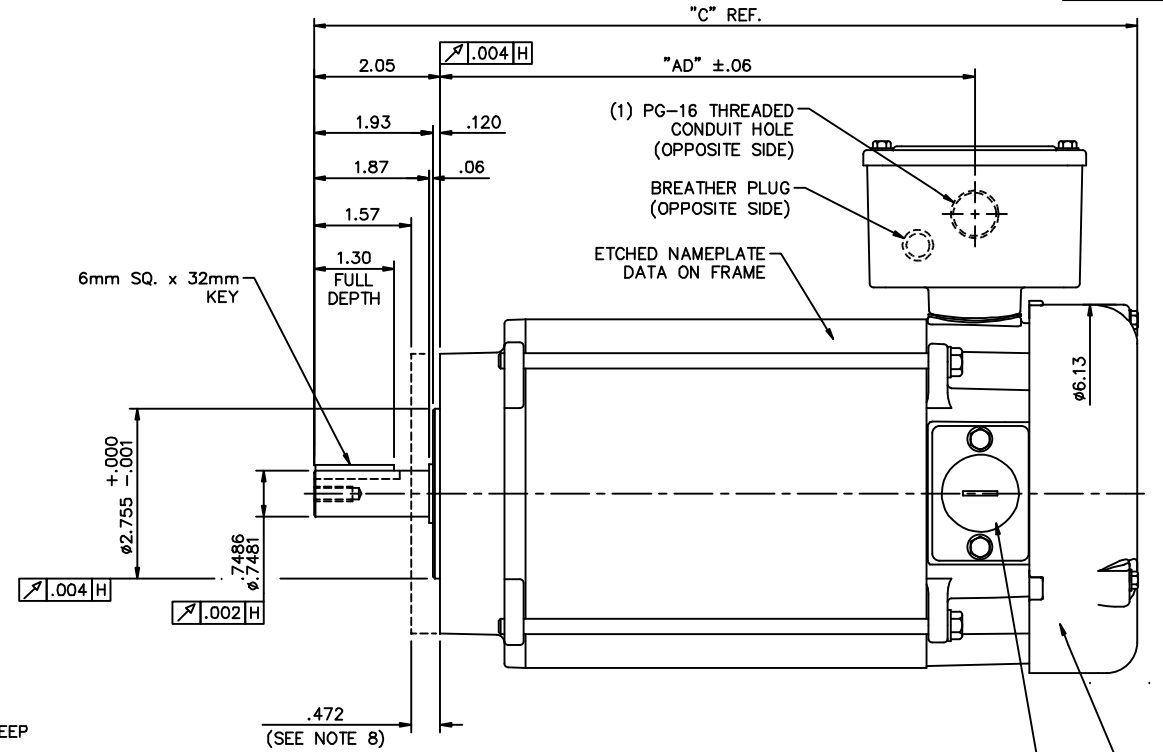

DASH NO.	"C"	"AD"
N80	12.87	8.16
R80	13.37	8.66
U80	13.87	9.16
V80	14.37	9.66
W80	14.87	10.16
X80	15.37	10.66
Y80	15.87	11.16
Z80	16.37	11.66

STAINLESS STEEL WASHGUARD MOTOR
SPECIAL FEATURES:

- 1) VITON CONDUIT BOX & COVER GASKETS.
- 2) VITON O-RINGS IN ENDBELL RABBETS.
- 3) VITON O-RINGS IN BRUSH HOLDER & CAP.
- 4) VITON SHAFT SEAL.
- 5) BREATHER PLUGS IN CONDUIT BOX & ENDBELL.
- 6) ETCHED NAMEPLATE DATA ON MOTOR FRAME.
- 7) ALL-STAINLESS STEEL CONSTRUCTION.
- 8) DIMENSION IS SPACE PROVIDED FOR A BOLT-ON B5 OR B14 ADAPTER KIT FOR IEC-80 FRAME.

NO.	REVISION	BY & DATE	CHK	ANG	TOLERANCES UNLESS SPECIFIED		TITLE	DRAWN PG 12/14/04	
					DEC.	INCHES			
02	CORRECTED LOCATION OF BREATHER PLUG AND PG-16 HOLE TO MATCH ENDBELL ASSEMBLY, ISAAC 12-0328	IPG 1/25/12	.X	±.1	±.03	 ELECTRIC MOTORS GEARMOTORS AND DRIVES	CHK		
01	ADDED FRAME DESIGNATION TO TABLE, PER 109090.00	IPG 2/4/05	.XXX	±.005	±.0005		APPD PG 12/14/04		
			.XXX	±1/2'	±.0005		SCALE 1-2		
THIS DRAWING IN DESIGN AND DETAIL IS OUR PROPERTY AND MUST NOT BE USED EXCEPT IN CONNECTION WITH OUR WORK ALL RIGHTS OF DESIGN AND INVENTION ARE RESERVED THIS IS AN ELECTRONICALLY GENERATED DOCUMENT - DO NOT SCALE THIS PRINT							MAT'L STAINLESS STEEL MOTOR FINISH	REF 030855 FMF 109090.00 PREV	
					RFP	CAD FILE 031792	SIZE B	DRAWING NO. 031792	REV. 02
					DIST				

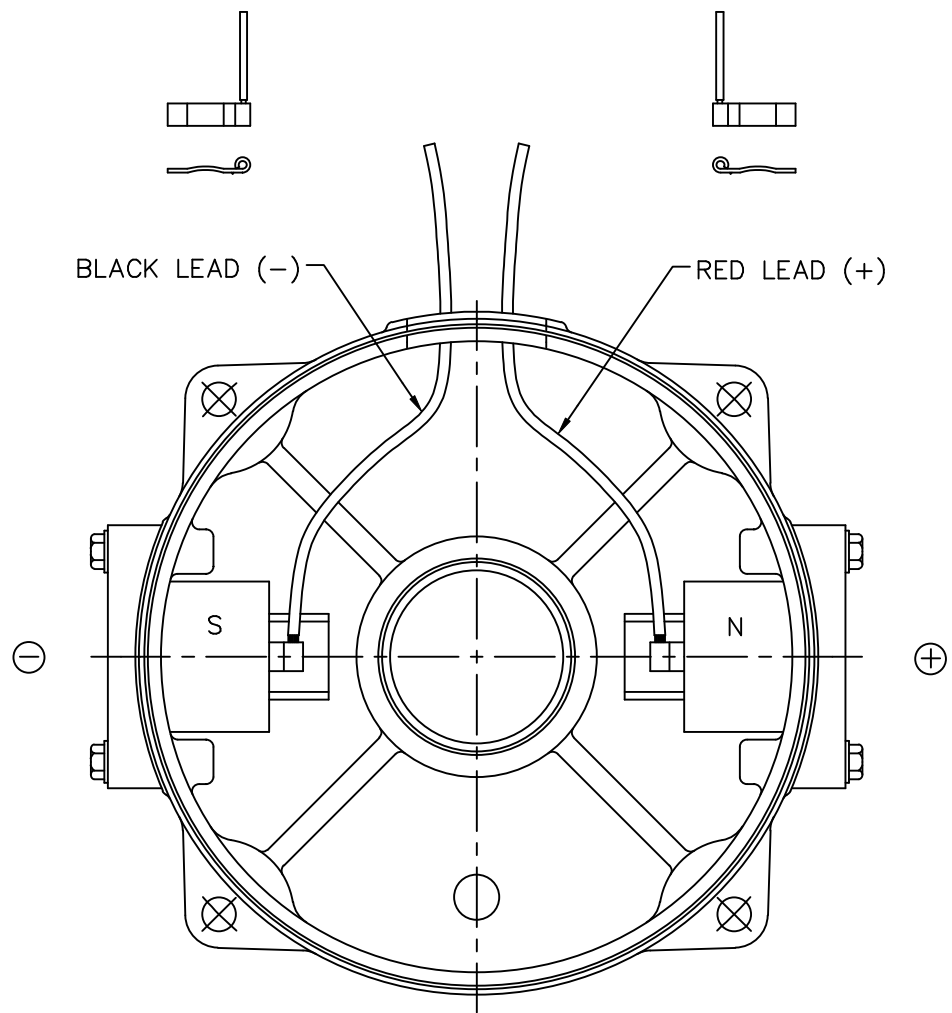

EXTERNAL CONNECTIONS FOR CCWLE ROTATION
 VIEWING LEAD END OF MOTOR WITH RED LEAD
 POSITIVE AND BLACK LEAD NEGATIVE.
 FOR CW ROTATION, REVERSE POLARITY.

				TOLERANCES UNLESS SPECIFIED		 ELECTRIC MOTORS GEARMOTORS AND DRIVES	DRAWN PG 12/10/04		
				DEC.	INCHES		CHK		
				.X	±.1		APPD PG 12/10/04		
				.XX	±.01		SCALE 5=8		
				.XXX	±.005		REF		
				.XXXX	±.0005	MAT'L.	FMF 109075.00		
NO.	REVISION	BY & DATE	CHK	ANG	±1/2"	FINISH	PREV		
THIS DRAWING IN DESIGN AND DETAIL IS OUR PROPERTY AND MUST NOT BE USED EXCEPT IN CONNECTION WITH OUR WORK ALL RIGHTS OF DESIGN AND INVENTION ARE RESERVED THIS IS AN ELECTRONICALLY GENERATED DOCUMENT - DO NOT SCALE THIS PRINT				RFP	CAD FILE	005487	SIZE	DRAWING NO.	REV.
				DIST			A	005487.01	