

# PRODUCT INFORMATION PACKET



Model No: P6C34FB23H  
Catalog No: 110402.00  
2HP..3450RPM.56H.TEFC.115/208-  
230V.1PH.60HZ.CONT.MANUAL.40C.1.0SF.RIGID.WOODWORKING.P6C34FB23H  
Totally Enclosed Fan Cooled (TEFC)



Regal and Leeson are trademarks of Regal Beloit Corporation or one of its affiliated companies.  
©2018 Regal Beloit Corporation, All Rights Reserved. MC017097E





### Nameplate Specifications

Output HP	2 Hp	Output KW	1.5 kW
Frequency	60 Hz	Voltage	115/208-230 V
Current	20.0/11.4-10.0 A	Speed	3450 rpm
Service Factor	1	Phase	1
Efficiency	73 %	Duty	Continuous
Insulation Class	F	Design Code	L
KVA Code	J	Frame	56H
Enclosure	Totally Enclosed Fan Cooled	Overload Protector	Manual
Ambient Temperature	40 °C	Drive End Bearing Size	6203
Opp Drive End Bearing Size	6203	UL	Recognized ( Not Protector)
CSA	Y	CE	N
IP Code	54		

### Technical Specifications

Electrical Type	Capacitor Start Induction Run	Starting Method	Across The Line
Poles	2	Rotation	Selective Counterclockwise
Mounting	Rigid base	Motor Orientation	HORIZONTAL
Drive End Bearing	BALL	Opp Drive End Bearing	BALL
Frame Material	Rolled Steel	Shaft Type	NEMA 56
Overall Length	13.48 in	Frame Length	8.00 in
Shaft Diameter	0.625 in	Shaft Extension	1.88 in
Assembly/Box Mounting	F1 ONLY		
Outline Drawing	028799-800B	Connection Diagram	005067.02

This document is the property of REGAL BELOIT CORPORATION ("RBC") including its subsidiaries and divisions and contains proprietary information of RBC. This document is loaned on the express condition that neither it nor the information contained therein shall be disclosed to others without the express written consent of RBC, and that the information shall be used by the recipient only as approved expressly by RBC. This document shall be returned to RBC upon its request. This document may be subject to certain restrictions under U.S. export control laws and regulations.

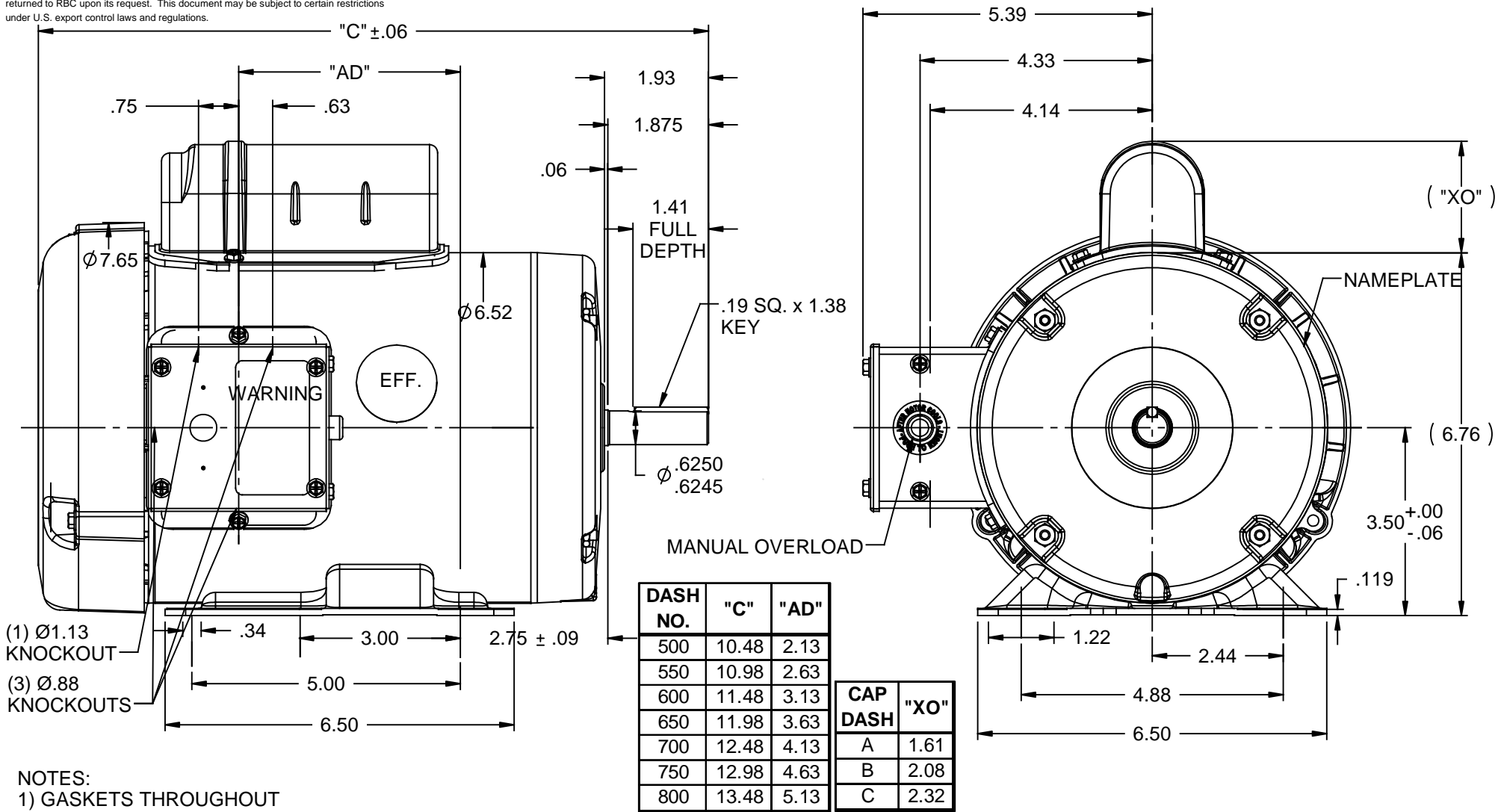

NOTES:  
1) GASKETS THROUGHOUT

		TOLERANCES UNLESS SPECIFIED		ELECTRIC MOTORS GEARMOTORS AND DRIVES	DRAWN KMM 09/25/07
		DEC	INCHES		CHK
		.X	±.1		APPR
		.XX	±.03		SCALE 3:8
		.XXX	±.005		REF 028657
		.XXXX	±.0005	MAT'L	FMF 110402.00
NO	REVISION	BY & DATE	CHK ANG ±1/2°	FINISH GENERAL PURPOSE	PAGE OF
			RFP	PREV	SIZE A
			NETWORK FILE NAME	DRAWING NO 028799	
					REV

VIEW FROM OUTSIDE OF MOTOR AT SWITCH END.

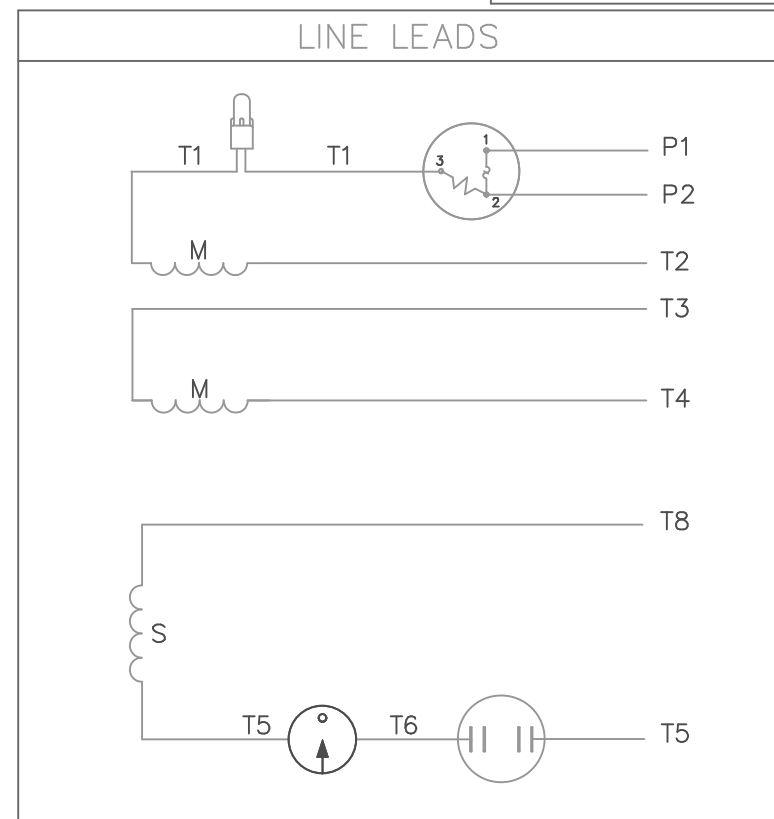
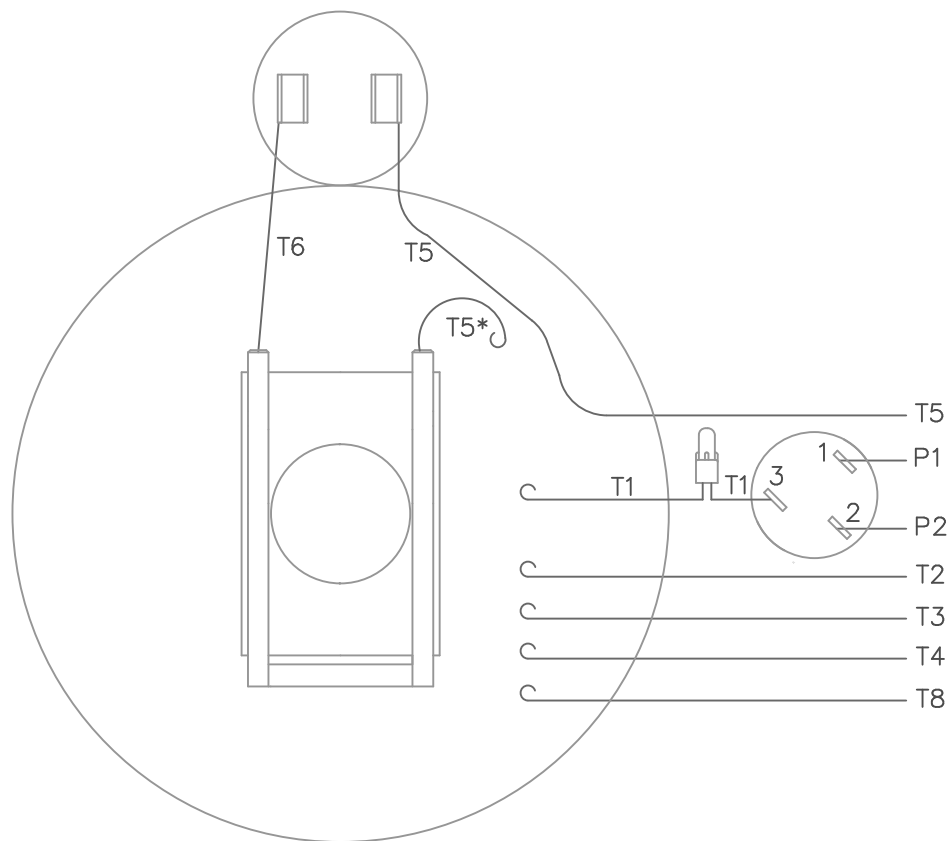

	ROTATION FACING LEAD END	L1	L2	JOIN	INSULATE SEPARATELY
HIGH VOLT	C.C.W.	P1	T4 T5	T2,T3 T8	P2
	C.W.	P1	T4 T8	T2,T3 T5	P2
LOW VOLT	C.C.W.	P1	T2,T4 T5	P2,T3 T8	
	C.W.	P1	T2,T4 T8	P2,T3 T5	

\* THIS LEAD MAY BE WHITE

				TOLERANCES UNLESS SPECIFIED		 ELECTRIC MOTORS GEARMOTORS AND DRIVES	DRAWN WLW 09/01/76			
				DEC.	INCHES		CHK			
05	ALTERNATE T5 LEAD MARKING WAS RED	RLW	8/6/02	.X	±.1	TITLE	EXT. WIRING DIAGRAM			
04	ADDED ALTERNATE T5 LEAD MARKING	RLW	5/31/02	KH	.XX	±.01	TYPE "C" W/ PROTECTOR			
03	DECAL WAS 004015	DBT	12/23/97		.XXX	±.005	MAT'L.	DECAL - 004011		
02	REDRAWN ON CAD	DBT	05/29/97		.XXXX	±.0005	FINISH			
NO.	REVISION	BY & DATE	CHK	ANG	±1/2'		PREV			
THIS DRAWING IN DESIGN AND DETAIL IS OUR PROPERTY AND MUST NOT BE USED EXCEPT IN CONNECTION WITH OUR WORK ALL RIGHTS OF DESIGN AND INVENTION ARE RESERVED THIS IS AN ELECTRONICALLY GENERATED DOCUMENT - DO NOT SCALE THIS PRINT				RFP	CAD FILE		00506702	SIZE	DRAWING NO.	REV.
				DIST	NLV			A	005067-02	05

