

PRODUCT INFORMATION PACKET



Model No: CZ6T17VC57A
Catalog No: 117272.00
..3/4HP..1725RPM.56.TENV.208-230/460V.3PH.60HZ.CONT.40C.1.15SF.C
FACE.CZ6T17VC57A.....NOT.....
3 Phase



Regal and Leeson are trademarks of Regal Beloit Corporation or one of its affiliated companies.
©2018 Regal Beloit Corporation, All Rights Reserved. MC017097E





Nameplate Specifications

Output HP	0.75 Hp	Output KW	0.56 kW
Frequency	60 Hz	Voltage	208-230/460 V
Current	2.4-2.3/1.2 A	Speed	1725 rpm
Service Factor	1.15	Phase	3
Efficiency	80 %	Duty	Continuous
Insulation Class	F	Design Code	B
KVA Code	L	Frame	56C
Enclosure	Totally Enclosed Non Ventilated	Overload Protector	No
Ambient Temperature	40 °C	Drive End Bearing Size	6205
Opp Drive End Bearing Size	6205	UL	Recognized
CSA	Y	CE	Y
IP Code	56		

Technical Specifications

Electrical Type	Squirrel Cage Inverter Rated	Starting Method	Line Or Inverter
Poles	4	Rotation	Reversible
Mounting	Round	Motor Orientation	HORIZONTAL
Drive End Bearing	BALL	Opp Drive End Bearing	BALL
Frame Material	Stainless Steel	Shaft Type	NEMA 56
Overall Length	11.72 in	Frame Length	6.50 in
Shaft Diameter	0.625 in	Shaft Extension	1.88 in
Assembly/Box Mounting	F1 ONLY		
Outline Drawing	028942-650	Connection Diagram	005010.01

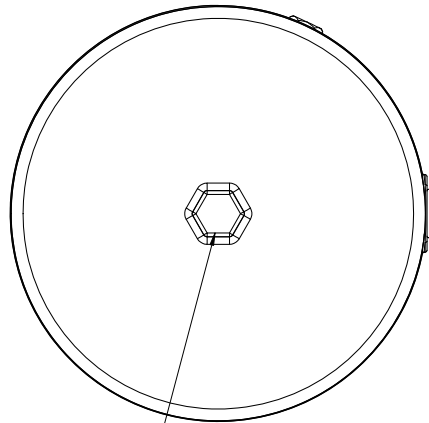

3/4" HEX DRIVER
FOR COVER REMOVAL

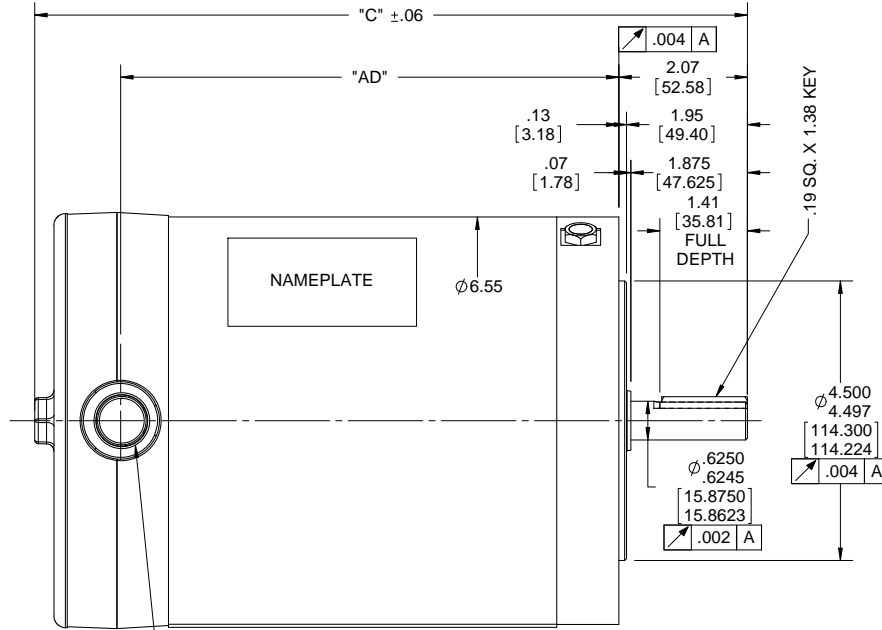

1/2-14 NPT CONDUIT
HOLE (PLUGGED)

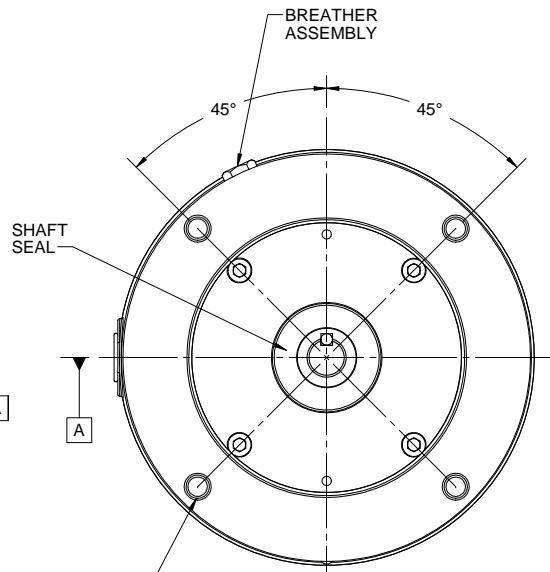

(4) 3/8-16 UNC-2B X .56
DEEP ON A Ø5.875 B.C.

DASH NO.	"C"	"AD"
525	10.47	7.00
550	10.72	7.25
575	10.97	7.50
600	11.22	7.75
625	11.47	8.00
650	11.72	8.25
675	11.97	8.50
700	12.22	8.75
750	12.72	9.25
800	13.22	9.75

DRAWING REVISION D	REVISION BY AS	DATE 05/04/2017
ECO ECO-0123079	APPROVED BY JD	DATE 05/04/2017
ECO DESCRIPTION ADDED ITEM # 800 & PLUGGED CONDUIT HOLE <small>© COPYRIGHT REGAL BELOIT AMERICA, INC. ALL RIGHTS RESERVED. PROPRIETARY AND CONFIDENTIAL INFORMATION - THIS DOCUMENT IS THE PROPERTY OF REGAL BELOIT AMERICA, INC. (OWNER) AND CONTAINS OWNER'S PROPRIETARY INFORMATION. ANY PERSON, CORPORATION OR OTHER FIRM RECEIVING IT IS DEEMED, BY RECEIVING IT, TO AGREE THAT IT, AND/OR ANY PART OF IT, SHALL NOT BE DISCLOSED TO ANY PERSON, CORPORATION OR OTHER ENTITY, DUPLICATED, AND/OR USED, EXCEPT AS EXPRESSLY APPROVED IN WRITING IN ADVANCE BY OWNER. THIS DOCUMENT SHALL BE RETURNED TO OWNER UPON REQUEST. IT MAY BE SUBJECT TO CERTAIN RESTRICTIONS UNDER APPLICABLE EXPORT CONTROL LAWS AND REGULATIONS.</small>		

TOLERANCES UNLESS OTHERWISE SPECIFIED:		
DEC.	INCH	mm
.X	±0.1	[±2.5]
.XX	±0.03	[±0.76]
.XXX	±0.005	[±0.127]
.XXXX	±0.0005	[±0.0127]
REMOVE BURRS & BREAK SHARP		
EDGES: .003/.015 [0.076/.381] X 45°		
CORNER FILLETS: R.02 [51]		
MACHINED SURFACES: 200 $\sqrt{5.1}$		
mm SHOWN IN [BRACKETS]		

DRAWN BY LST 1/9/09	DATE
APPROVED BY	DATE
REFERENCE	THIRD ANGLE PROJECTION

Regal Beloit America, Inc.	
DESCRIPTION	
OUTLINE TENV ROUND "C" FACE	
MATERIAL	PROCESS/FINISH
SIZE B	DRAWING NUMBER 028942
	SHEET 1 OF 1

005010-01

VIEW FROM OUTSIDE OF MOTOR AT SWITCH END.

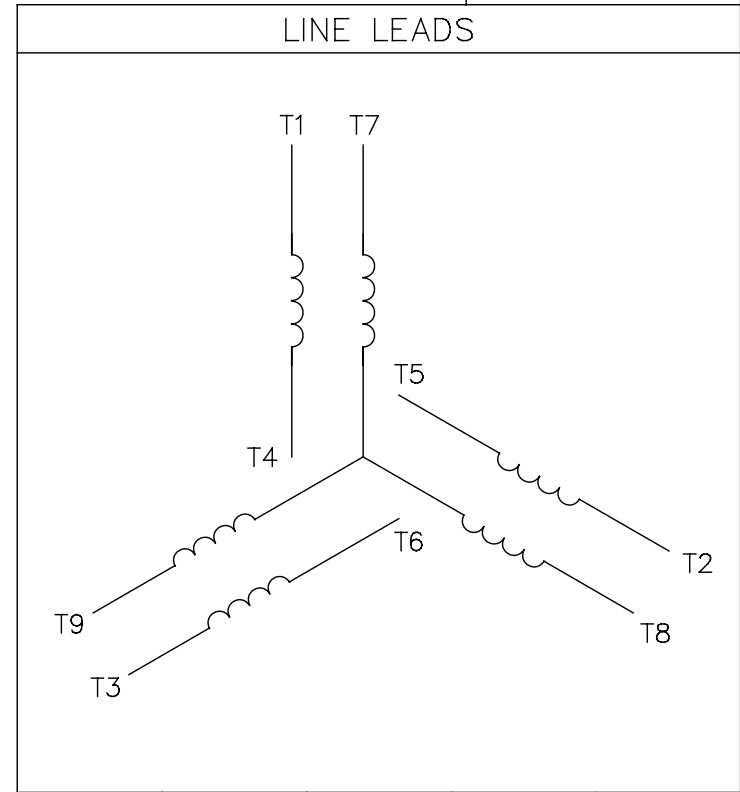

VOLTAGE	L1	L2	L3	JOIN & INSULATE
HIGH	T1	T2	T3	(T4,T7) (T5,T8) (T6,T9)
LOW	T1,T7	T2,T8	T3,T9	T4,T5,T6

				TOLERANCES UNLESS SPECIFIED		Regal Beloit America, Inc.		DRAWN RDW 04/12/02				
				DEC.	INCHES			CHK				
				.X	±.1			APPD				
				.XX	±.01			SCALE 1=1				
				.XXX	±.005	TITLE		REF FIG.2-51				
A	UPDATED TO REGAL LOGO			SAJ	06/26/15	AJY	.XXXX	±.0005	MAT'L.	DECAL - 004014	FMF	
NO.	REVISION			BY & DATE	CHK	ANG	±1/2"	FINISH			PREV	
THIS DRAWING IN DESIGN AND DETAIL IS OUR PROPERTY AND MUST NOT BE USED EXCEPT IN CONNECTION WITH OUR WORK ALL RIGHTS OF DESIGN AND INVENTION ARE RESERVED THIS IS AN ELECTRONICALLY GENERATED DOCUMENT - DO NOT SCALE THIS PRINT				RFP	04/12/02		CAD FILE	00501001		SIZE	DRAWING NO.	
				DIST	BRF-NLV				A	005010-01		REV.

