

# INFORMATION IN THIS DRAWING PROVIDED FOR REFERENCE ONLY

SCALE 2 : 1

REVISIONS				
ZONE	REV.	DESCRIPTION	DATE	APPROVED

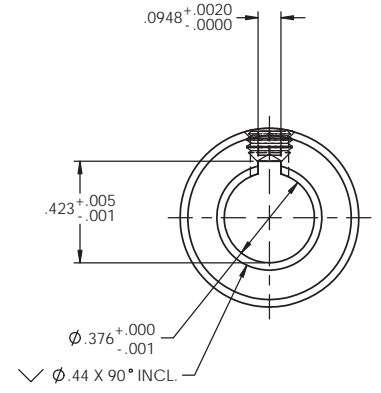
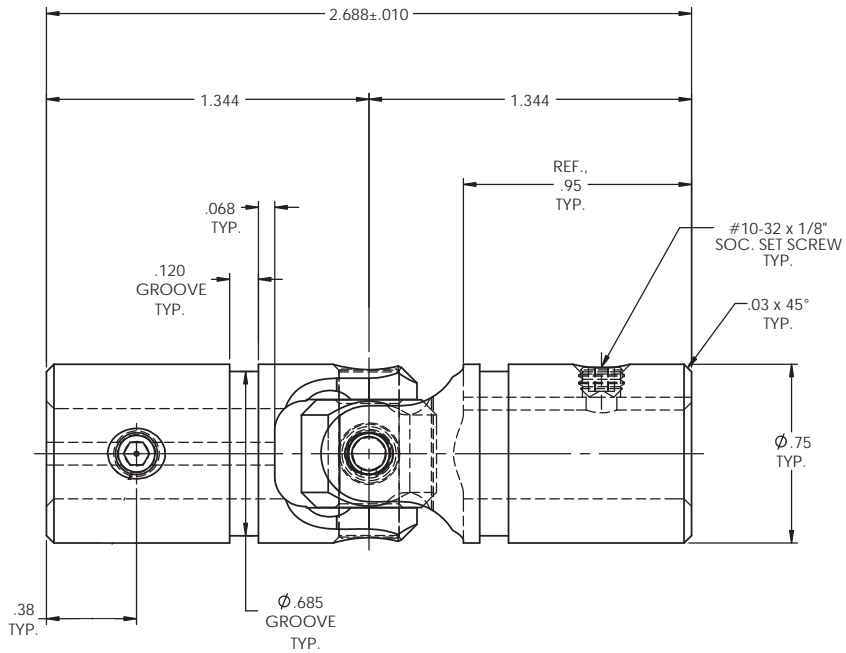
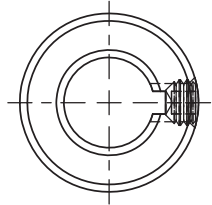

TYPICAL BOTH ENDS

NOTE(s), UNLESS OTHERWISE SPECIFIED.

- (1) UNIVERSAL JOINT IS MARKED w/ "BELDEN" LOGO, PART NUMBER / DRAWING NUMBER, REVISION LEVEL (IF ANY), DATE OF MANUFACTURE (MO/YR), AND BELDEN JOB NUMBER.
- (2) UNIVERSAL JOINT IS LUBRICATED w/ LUBRIPLATE 1200-2, NLGI GRADE 2, AW/EP, LITHIUM GREASE OR EQUIVALENT.
- (3) UNIVERSAL JOINT IS CAPABLE OF OPERATING AT ANY ANGLE UP TO AND INCLUDING 45°.
- (4) UNIVERSAL JOINT HAS STANDARD GROOVES TO ACCEPT INSTALLATION OF PROTECTIVE COVER (BOOT). BOOT AVAILABLE SEPARATELY. REFER TO BELDEN CATALOG, WEBSITE, OR CONTACT BELDEN SALES.
- (5) REFER TO BELDEN CATALOG, WEBSITE, OR CONTACT BELDEN SALES FOR TORQUE CAPACITY.
- (6) THIS DRAWING REPRESENTS A STANDARD BELDEN ITEM. CUSTOM UNIVERSAL JOINTS ARE AVAILABLE UPON REQUEST. PLEASE CONTACT BELDEN SALES.

**BELDEN PART NUMBER: UJ-HD750x375K**

DO NOT SCALE DRAWING

UNLESS OTHERWISE SPECIFIED CHAMFER ALL HOLES BREAK ALL SHARP CORNERS DE-BURR ALL FEATURES TURNED SURFACES: $\sqrt{6.3}$ MILLED SURFACES: $\sqrt{125}$ PROPRIETARY AND CONFIDENTIAL THE INFORMATION CONTAINED IN THIS DRAWING IS THE SOLE PROPERTY OF BELDEN INCORPORATED. NO PART OR WHOLE REPRODUCTION IN PART OR AS A WHOLE WITHOUT THE WRITTEN PERMISSION OF BELDEN INCORPORATED IS PROHIBITED.	STANDARD TOLERANCES, UNLESS OTHERWISE SPECIFIED DIMENSIONS ARE IN INCHES [mm]	MATERIAL: ALLOY STEEL HEAT TREAT: SEE DETAIL DRAWINGS FINISH: NONE	NAME: JP DATE: 23MART12 CHECKED: RNK DATE: 17APR12 ENG APPR: RNK DATE: 17APR12 MFG APPR: [ ] DATE: [ ] COMMENTS:	Belden Incorporated <a href="http://www.beldenuniversal.com">www.beldenuniversal.com</a> TITLE: ASSEMBLY, UNIVERSAL JOINT SIZE: C DWG. NO.: UJ-HD750x375K REV: [ ] SCALE: 2.5:1 WT (Lbs): 0.224 SHEET 1 OF 2
	ANGULAR MACHINED: ±1.0° FRACTIONAL: ±.015" TWO PLACE DECIMAL: ±.010" THREE PLACE DECIMAL: ±.005" FOUR PLACE DECIMAL: ±.0005" CONCENTRICITY: .0025" T.I.R.	ALL HOLES TO BE LOCATED ON CENTERLINE (C) WITHIN .005" T.I.R. INTERPRET GEOMETRIC TOLERANCES I.A.W. ANSI Y14.5M-1992		