

# DUTY MASTER ALTERNATING CURRENT MOTORS

SQUIRREL-CAGE INDUCTION

COOLING: FAN COOLED

ENCLOSURE: UL LISTED MOTOR

FRAME G447T ABOVE NEMA RATINGS (1800 RPM MAX)

INCLUDES G449T FRAME MOUNTING HOLES

MOUNTING: FOOT, F-1

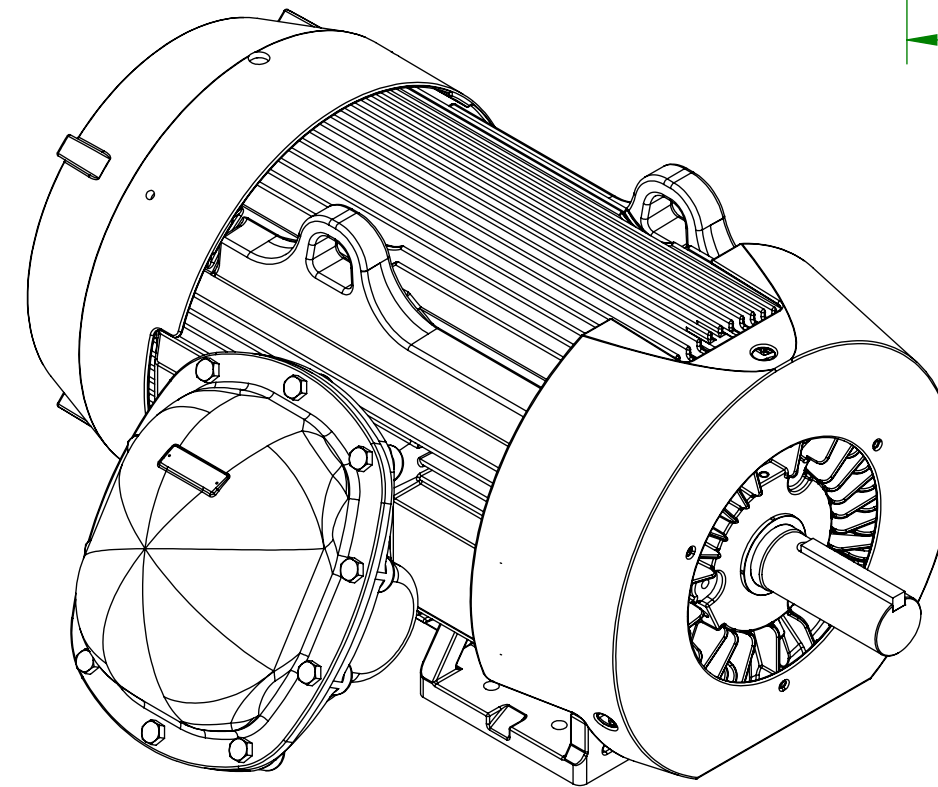
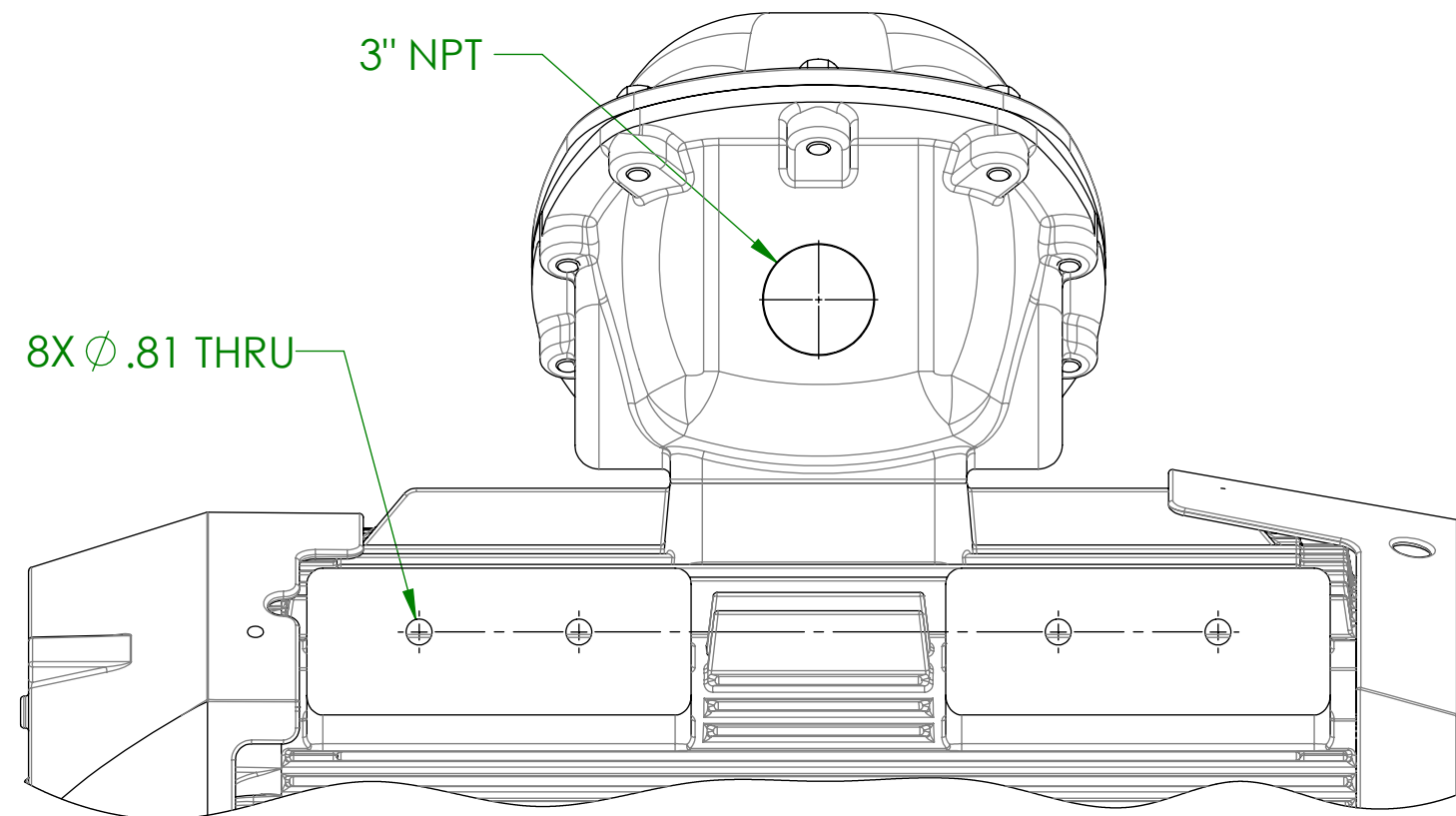
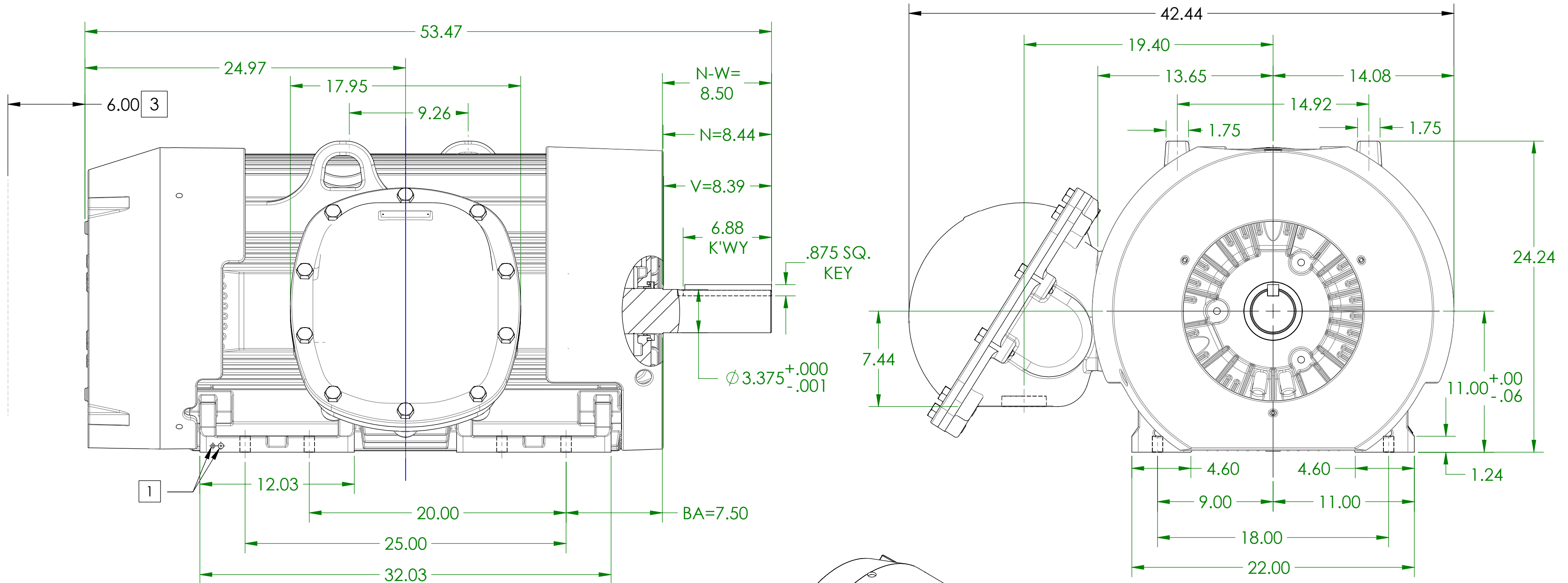

- 1 GROUND HOLES QTY 1 1/2-13 TAP; QTY 1 3/8-16 TAP
- 2 MOTOR WEIGHTS MAY VARY BY 15% DEPENDING ON RATING.
- 3 OBSTRUCTION MUST NO ENCROACH ON AIR INLET

2 WEIGHT (LBS): 3180

DIMENSIONS ARE IN INCHES

CUSTOMER IS RESPONSIBLE FOR DETERMINING THAT MOTOR PERFORMANCE IS SUITABLE IN THE APPLICATION.

SHEET NUMBER  
1 OF 1

617426-166

IF MOUNTING CLEARANCE DETAILS ARE REQUIRED, CONSULT FACTORY.  
MAXIMUM PERMISSIBLE SHAFT RUNOUT WHEN MEASURED AT END OF  
STANDARD SHAFT EXTENSION IS .003" T.I.R. TO 5 INCH DIA.

REV. DESC: NEW ISSUE			
REV: -	VERSION: 00	REVISED: 09:37:40 04/21/2016	TDR: 000000976634
MODEL NO. 617426-166			
BY: RAGGDM			

## BALDOR

G449T/447T XP FT SIDE/CTR C/B - CL 1 C / CL 2 E,F & G 3"NPT